

Contact Arizona 811 at least two full working days before you begin excavation
ARIZONA 811
 Call 811 or click Arizona811.com

Benchmark Info
 The Benchmark for the project is the West Quarter Corner of Section 35, T.1S., R.7E., G4SRM
 Elevation = 1403.67'

SHEET LEGEND
 - - - - - DRAINAGE BASIN BOUNDARY

- EAST RETENTION BASIN**
 BASIN SIZE = 101.09 ACRES
 REQUIRED STORAGE = 657,229 CF (100-YEAR, 2-HR)
 PROVIDED STORAGE = 691,834 CF @ 1407.30
 HIGH WATER ELEVATION = 1407.30
 BOTTOM OF BASIN = 1405.50
 RELEASE RATE = 7.61 CFS (DRAINS POND IN 24-HR)
 ORIFICE = 11.8 INCH @ 1400.10
- WEST RETENTION BASIN**
 BASIN SIZE = 77.26 ACRES
 REQUIRED STORAGE = 553,357 CF (100-YEAR, 2-HR)
 PROVIDED STORAGE = 574,457 CF
 HIGH WATER ELEVATION = 1405.00
 BOTTOM OF BASIN = 1403.00
 RELEASE RATE = 6.40 CFS (DRAINS POND IN 24-HR)
 ORIFICE = 13.1 INCH @ 1400.00

West Retention Pond				East Retention Pond			
Elevation (#2)	Area (#3)	Volume (#3)	Acc. Volume (#3)	Elevation (#2)	Area (#3)	Volume (#3)	Acc. Volume (#3)
1402.00	163,852	0	0	1405.50	154,356	0	0
1403.00	182,234	173,043	173,043	1406.00	156,722	77,770	77,770
1404.00	200,689	191,462	364,505	1407.00	161,509	159,116	236,885
1405.00	219,215	209,952	574,457	1407.30	162,959	48,670	285,555

North Retention Pond			
Elevation (#2)	Area (#3)	Volume (#3)	Acc. Volume (#3)
1405.50	220,073	0	0
1406.00	223,198	110,818	110,818
1407.00	229,503	226,351	337,168
1407.30	231,235	69,111	406,279

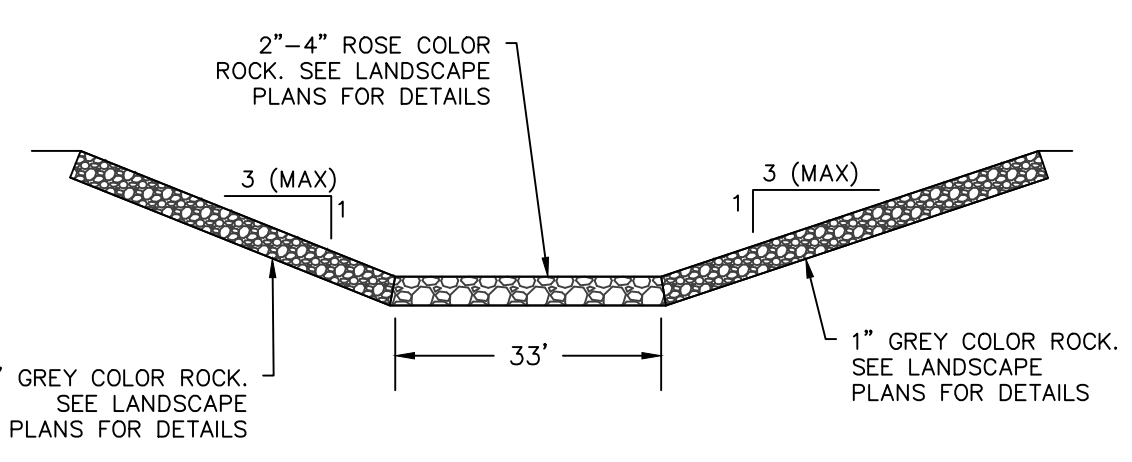

INTERSTATE L24

Pecos Rd

Grismon Rd

NO.	REVISIONS	BY	DATE

CIR CIVIL ENGINEERING + SURVEYING
 107718 S BECKSTEAD LANE, SUITE 102
 South Jordan, Utah - 84064-6206

PROJECT: METEOR
 222ND PECOS RD, MESA, ARIZONA
 MASTER GRADING & DRAINAGE PLAN

PROJECT NO. 1000
 ISSUE DATE: 06/28/24
 SHEET NO. MG