

**WARE MALCOMB**  
Leading Design for Commercial Real Estate

architecture  
planning  
interiors  
graphics  
civil engineering  
2777 E. Camelback Rd., Suite 325  
Phoenix, AZ 85016  
PHX 987.757.1001  
F 480.947.2285



**SOSSAMAN 202 INDUSTRIAL PARK**  
S. SOSSAMAN ROAD  
MESA, ARIZONA

DATE	REMARKS

PA / PM: B. SANDSTROM  
DRAWN BY: T.D.  
JOB NO.: PHX21-0009-00

SHEET  
**A1.1**

### SITE PLAN KEYNOTES

- PROPERTY LINE (---)
- LANDSCAPE SET BACK
- ADA PARKING STALL
- CITY STD. CMU TRASH ENCLOSURE, SEE DETAIL 8/A6.0
- EXISTING PROPERTY LINE
- 8' CMU SCREEN WALL, SEE DETAIL 11/A6.0
- SOLID 8' B-DECK GATE, SEE DETAIL 12/A6.0
- NEW 6" CURB, SEE CIVIL
- NEW 12" CURB, SEE CIVIL
- NEW PARKING STRIPING TO MATCH CITY STANDARDS
- VISIBILITY TRIANGLE, SEE CIVIL
- 26' - 0" MIN. CLEAR FIRE LANE PROVIDED TO FRONT BUILDINGS, PER COM STAN
- PARKING SCREEN WALL
- RETENTION BASIN
- PROPOSED FUTURE MONUMENT SIGN LOCATION
- 9'-0" x 18'-0" TYPICAL PARKING STALL
- SIDEWALK. 5'-0" MIN. WIDE
- OFFSITE DRAINAGE CHANNEL, SEE CIVIL FOR ADDITIONAL INFORMATION
- IRON FENCE, PAINTED.
- 8'-0" WIDE SIDEWALK AT ROW.
- COMMON PATH OF TRAVEL INTO PHASE 1.
- LANDSCAPE SETBACK.
- BUILDING SETBACK.
- BICYCLE PARKING.
- PEDESTRIAN ROUTE.

### PROJECT DESCRIPTION

THIS PROJECT IS FOR THE MASTER PLANNING OF 9 NEW SHELL INDUSTRIAL BUILDINGS BUILT OVER 3 SEPARATE PHASES. MASTER PLANNING FOR THE ENTIRE PROJECT IS PART OF THIS SCOPE. BUILDINGS 1-3 (PHASE 1) ARE ALSO PART OF THIS SCOPE.

PHX21-0009-00 SOSSAMAN 202 INDUSTRIAL PARK	TABULAR DATA	TABLE AREA	PERCENT COVERED
CONCRETE SITE COVERAGE	422,563.0	9.7	9.1
ASPHALT SITE COVERAGE	1,555,714.0	35.7	33.5
BUILDING 1 COVERAGE	163,078.0	3.7	3.5
BUILDING 2 COVERAGE	194,278.0	4.5	4.2
BUILDING 3 COVERAGE	130,318.0	3.0	2.8
BUILDING 4 COVERAGE	494,192.0	11.3	10.7
BUILDING 5 COVERAGE	108,478.0	2.5	2.3
BUILDING 6 COVERAGE	119,398.0	2.7	2.6
BUILDING 7 COVERAGE	88,224.0	2.0	1.9
BUILDING 8 COVERAGE	88,224.0	2.0	1.9
BUILDING 9 COVERAGE	88,224.0	2.0	1.9
<b>TOTAL IMPERVIOUS SITE AREA COVERAGE</b>	<b>3,452,691.0</b>	<b>79.3</b>	<b>74.4</b>
LANDSCAPE COVERAGE	1,185,295.0	27.2	25.6
<b>TOTAL PERVIOUS SITE AREA COVERAGE</b>	<b>1,185,295.0</b>	<b>27.2</b>	<b>25.6</b>
<b>TOTAL AREA COVERAGES</b>	<b>4,637,986.0</b>	<b>106.5</b>	<b>100.0</b>

  

DEVELOPMENT STANDARDS (U)	CITY OF MESA STANDARD	PAD PROPOSED / PROVIDED
LOT AND DENSITY STANDARDS	AG & LI	LI WITH PAD
MINIMUM SITE AREA (ACRES)	1.0 ACRES	4,291,645 SF (122.4 ACRES) NET
MINIMUM LOT WIDTH (FEET)	300	74.4% NET, 78.6% GROSS
MINIMUM LOT DEPTH (FEET)	150	50'-0"
MINIMUM LOT COVERAGE (ON DE LOT)	50	78.6% NET, 78.6% GROSS
BUILDING FORM AND LOCATION	40'-0"	50'-0"
CONSTRUCTION TYPE	UNLIMITED	UNLIMITED
MINIMUM SETBACK ALONG PROPERTY LINES OR BUILDING AND PARKING AREAS	20'-0"	20'-0"
FRONT & STREET SIDING (INDUSTRIAL / COMMERCIAL COLLECTION)	20'-0"	20'-0"
INTERIOR SIDE AND REAR (ADJACENT TO LI OR DR IN DISTRICT)	PLAN SPECIFIC	PLAN SPECIFIC
APPLICABLE SUPPLEMENTAL STANDARDS	15' WIDE AT SITE PERIMETER	20'-0"
LANDSCAPING	15' WIDE AT SITE PERIMETER	20'-0"
OFF-STREET PARKING	SHELL WAREHOUSE: 37900 SF TOTAL REQUIRED: 1,888	1877 STANDARD 154 TRAILER
TYPICAL PARKING SPACE DIMENSION (90 DEGREE, STANDARD VEHICLE)	9'-0" X 18'-0" 1 SPACE PER 50 CAR PARKING + 50 1 SPACE PER 25 CAR PARKING AFTER 10 BICYCLE PARKING PROVIDED + 136 TOTAL BICYCLE PARKING REQUIRED: 108	9' X 18' 10 SPACES PER BUILDING + 90 26'-0" 15'-0" TO 30'-0"
BICYCLE PARKING	15'-0" TO 30'-0"	10 SPACES PER BUILDING + 90
FIRE ACCESS LANE WIDTH	26'-0"	26'-0"
DISTANCE FROM FIRE LANE TO BUILDING	15'-0" TO 30'-0"	15'-0" TO 30'-0"

### SITE LEGEND

- △ KNOCK OUT DOOR
- ▲ DOCK HIGH TRUCK DOOR
- GRADE LEVEL TRUCK DOOR
- FIRE HYDRANT (VERIFY LOCATION WITH CIVIL DRAWINGS)

### VICINITY MAP

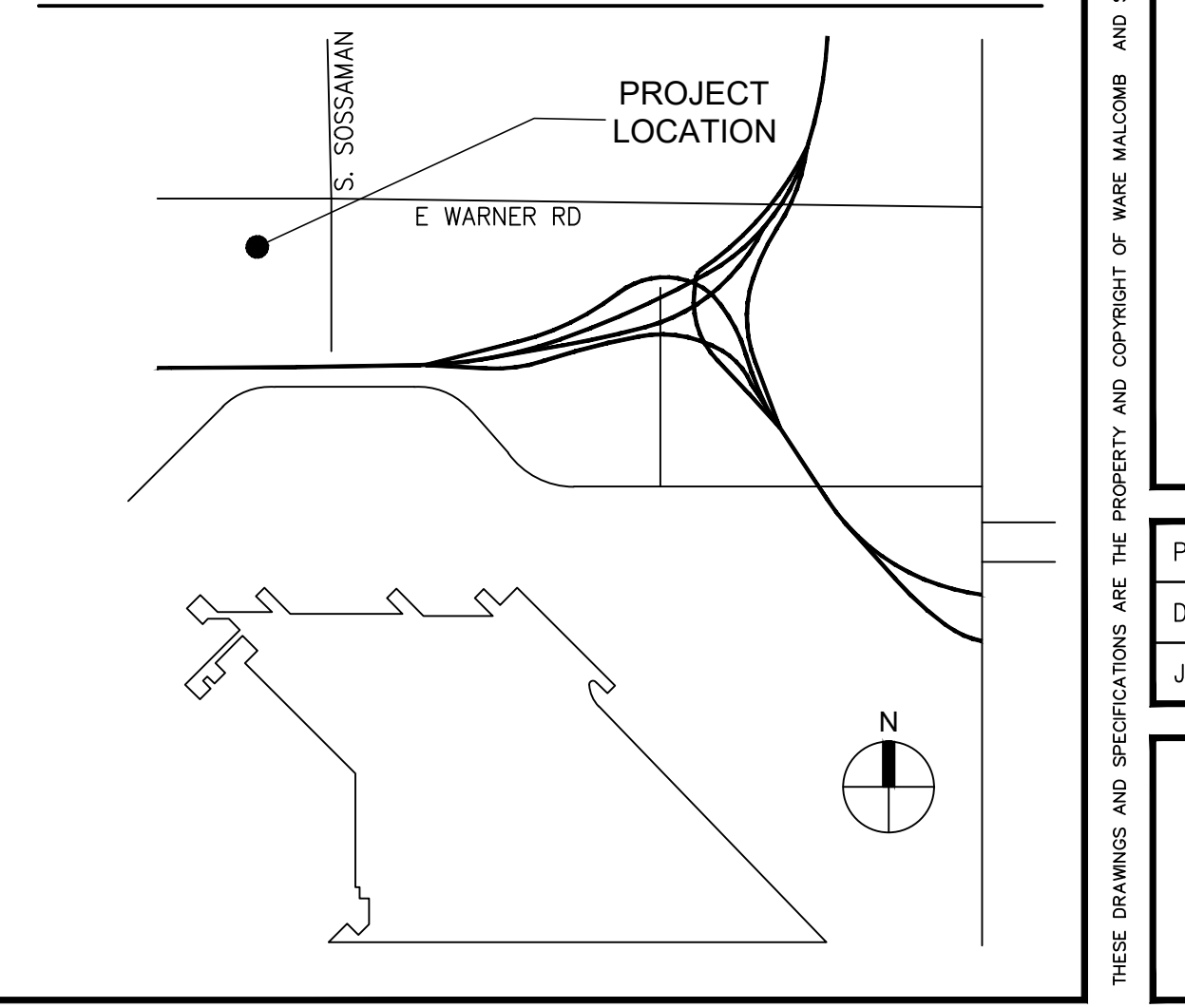

SOSSAMAN 202 SITE AREA INFORMATION	SQUARE FEET	ACRES	PERCENT COVERED
CONCRETE SITE COVERAGE	422,563.0	9.7	9.1
ASPHALT SITE COVERAGE	1,555,714.0	35.7	33.5
BUILDING 1 COVERAGE	163,078.0	3.7	3.5
BUILDING 2 COVERAGE	194,278.0	4.5	4.2
BUILDING 3 COVERAGE	130,318.0	3.0	2.8
BUILDING 4 COVERAGE	494,192.0	11.3	10.7
BUILDING 5 COVERAGE	108,478.0	2.5	2.3
BUILDING 6 COVERAGE	119,398.0	2.7	2.6
BUILDING 7 COVERAGE	88,224.0	2.0	1.9
BUILDING 8 COVERAGE	88,224.0	2.0	1.9
BUILDING 9 COVERAGE	88,224.0	2.0	1.9
<b>TOTAL IMPERVIOUS SITE AREA COVERAGE</b>	<b>3,452,691.0</b>	<b>79.3</b>	<b>74.4</b>
LANDSCAPE COVERAGE	1,185,295.0	27.2	25.6
<b>TOTAL PERVIOUS SITE AREA COVERAGE</b>	<b>1,185,295.0</b>	<b>27.2</b>	<b>25.6</b>
<b>TOTAL AREA COVERAGES</b>	<b>4,637,986.0</b>	<b>106.5</b>	<b>100.0</b>

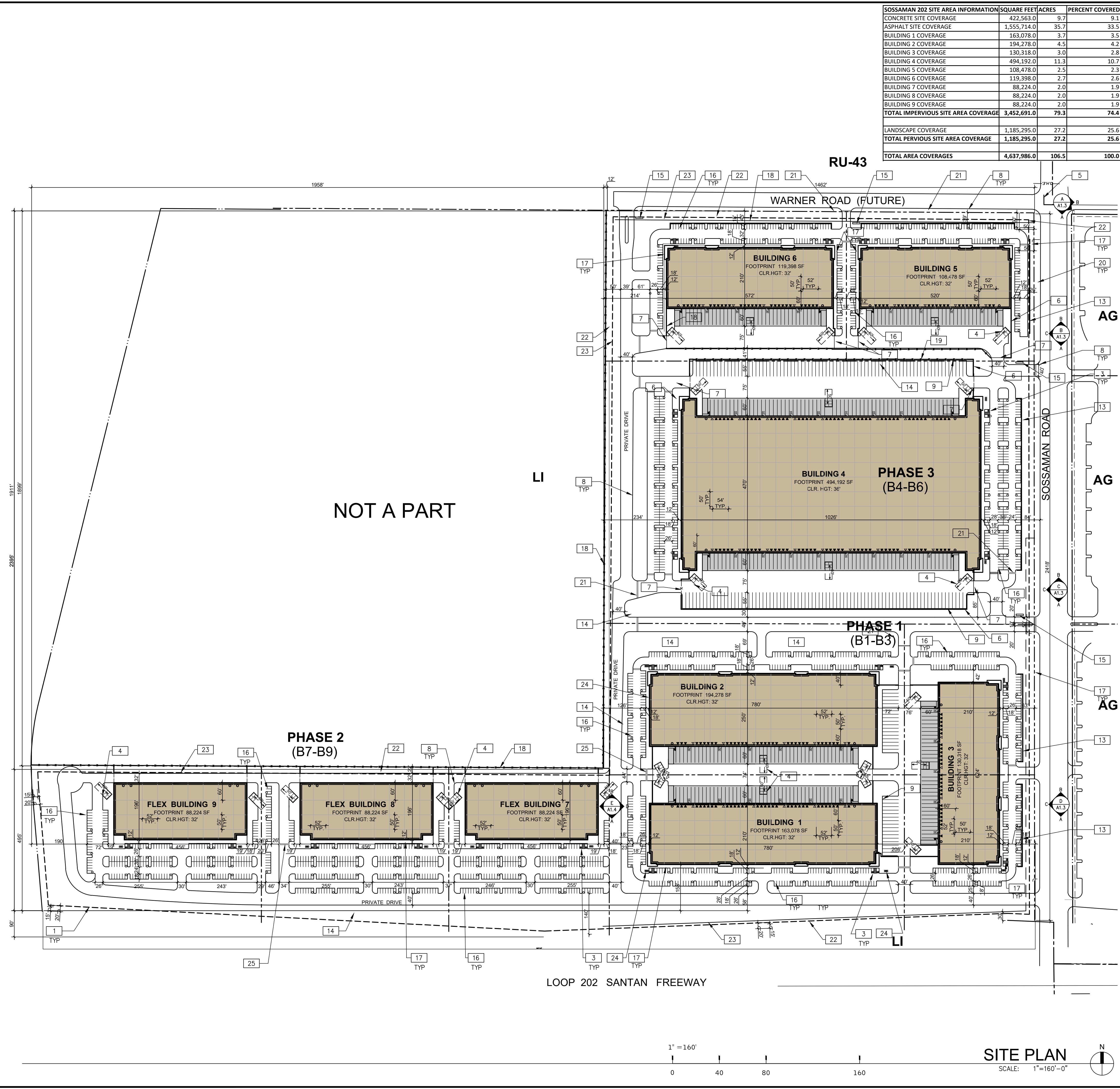

W:\PHX\21\0009\000\Architectural\Cad\PLANNING\0009\_A.1\_SP.3\_2021-08-06.dwg

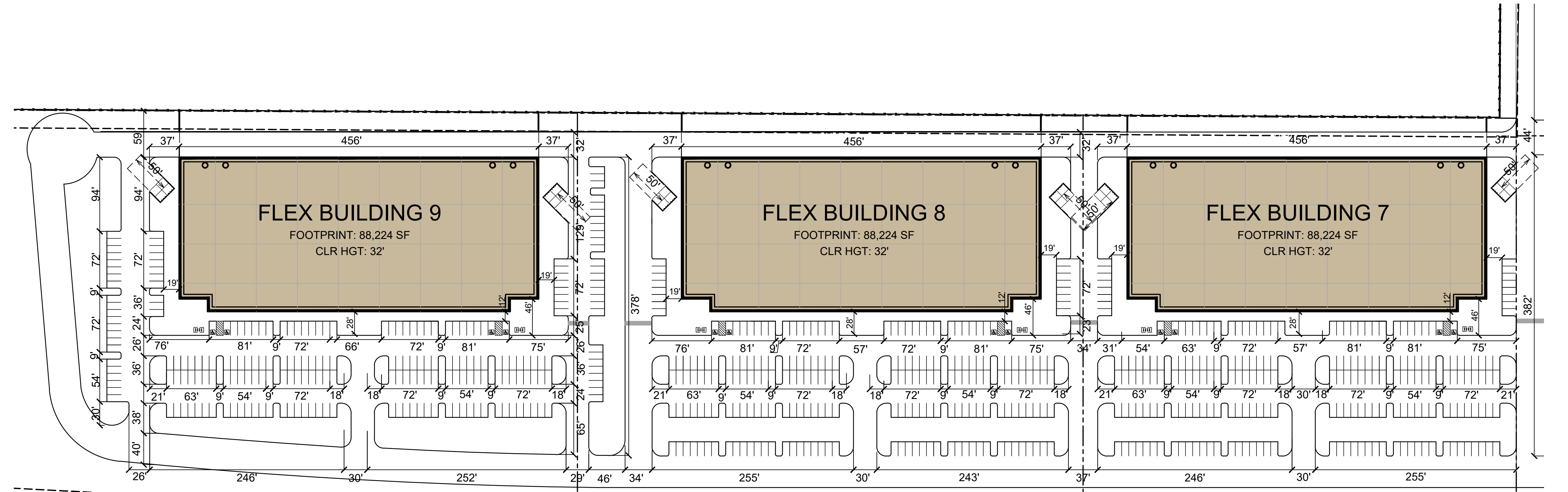

PHASE 2 - ENLARGED SITE PLAN

SCALE: 1"=80'-0"

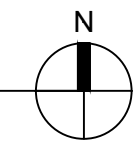

W:\PHX\21\0009\00\Architectural\Cad\DD\PLANNING\0009\_A1.2 Phase Exhibits SP3.1.dwg

**WARE MALCOMB**  
 Leading Design for Commercial Real Estate

architecture  
 planning  
 interiors  
 graphics  
 civil engineering

2777 E. Camelback Rd., Suite 325  
 Phoenix, AZ 85016  
 P 480.757.1001  
 F 480.907.2288



**SOSSAMAN 202 INDUSTRIAL PARK**  
 S. SOSSAMAN ROAD  
 MESA, ARIZONA

SITE PLAN	
DATE	REMARKS

PA / PM:	B. SANDSTROM
DRAWN BY:	D.V.
JOB NO.:	PHX21-0009-00

SHEET  
**A1.3**

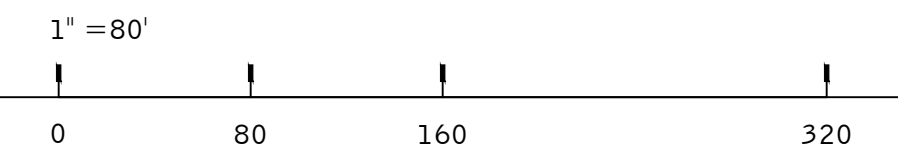
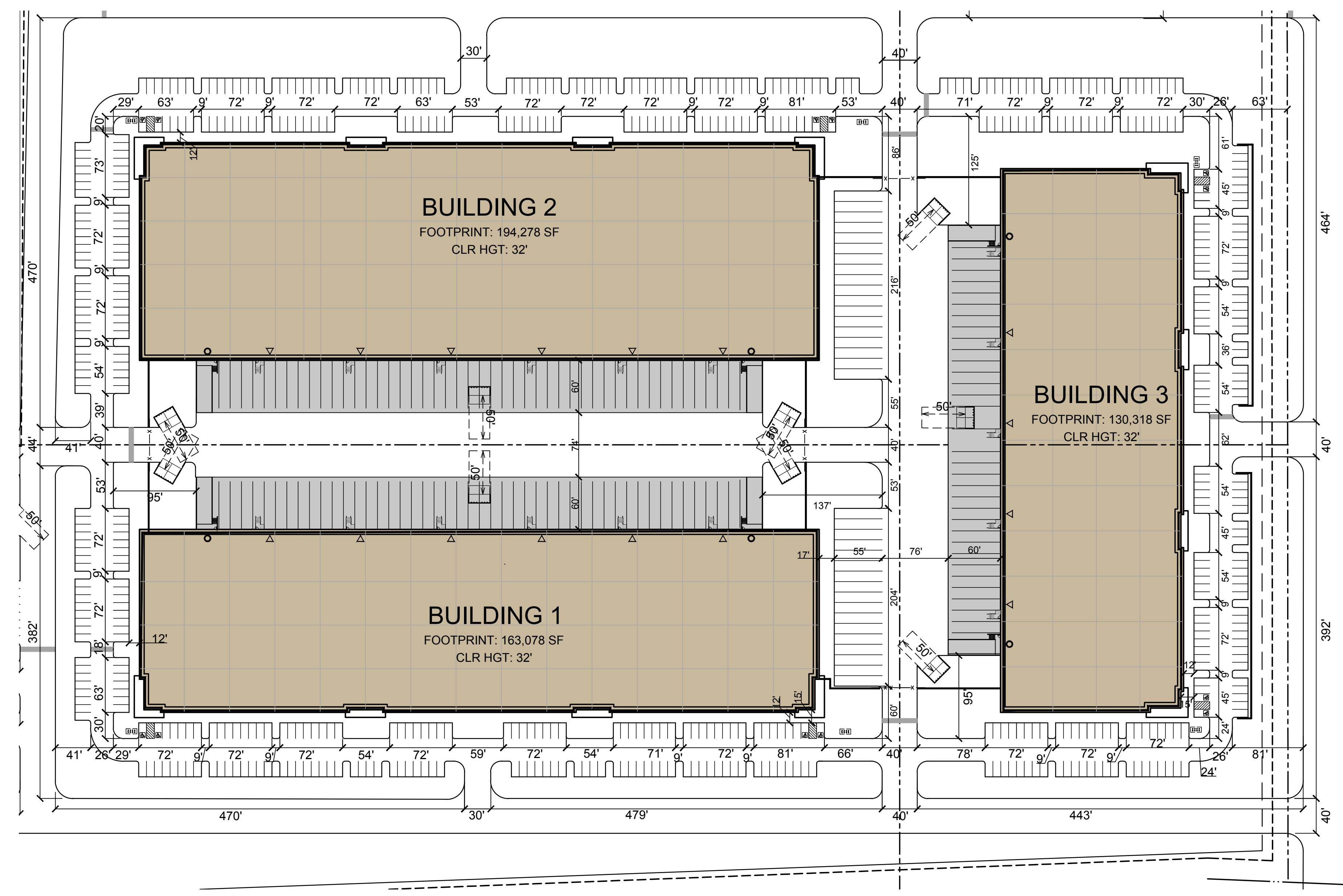

PHASE 1 - ENLARGED SITE PLAN

SCALE: 1"=80'-0"

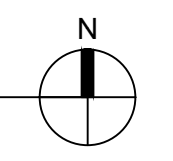

\\wma-arch.com\wm\PHX\21\0009\00\Architectural\Cad\DD\PLANNING\0009\_A1.2\_Phase Exhibits\_SF3.1.dwg

**WARE MALCOMB**  
 Leading Design for Commercial Real Estate

architecture  
 planning  
 interiors  
 graphics  
 civil engineering  
 2777 E. Camelback Rd., Suite 325  
 Phoenix, AZ 85016  
 P 480.757.1001  
 F 480.907.2286

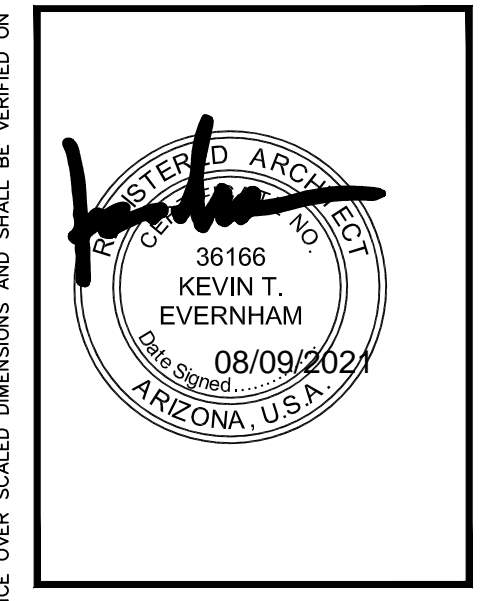

**SOSSAMAN 202 INDUSTRIAL PARK**  
 S. SOSSAMAN ROAD  
 MESA, ARIZONA

SITE PLAN	
DATE	REMARKS

PA / PM:	B. SANDSTROM
DRAWN BY:	D.V
JOB NO.:	PHX21-0009-00

SHEET  
**A1.2**

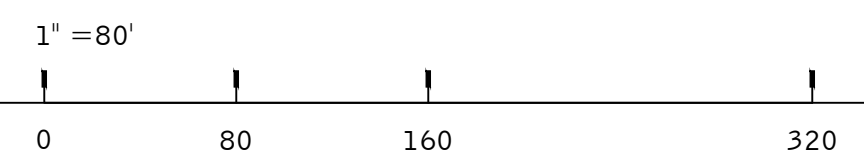
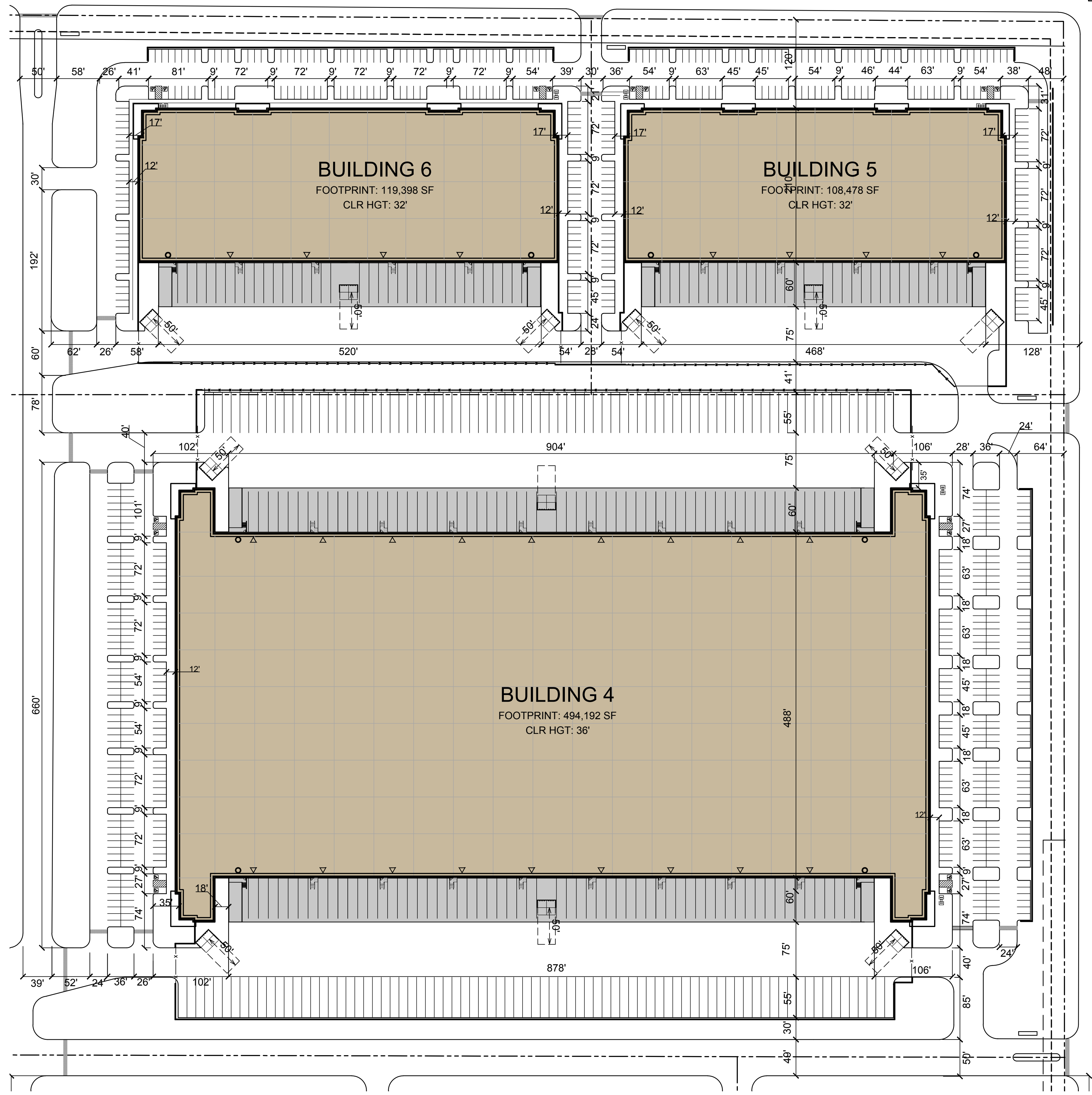

PHASE 3 - ENLARGED SITE PLAN

SCALE: 1"=80'-0"

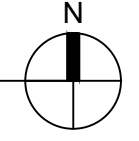

\\wma-arch.com\wma\PHX\21\0009\00\Architectural\Cad\DD\PLANNING\0009\_A1.2\_Phase Exhibits\_SF3.1.dwg

**WARE MALCOMB**  
 Leading Design for Commercial Real Estate

architecture  
 planning  
 interiors  
 graphics  
 civil engineering

2777 E. Camelback Rd., Suite 325  
 Phoenix, AZ 85016  
 P 602.757.1001  
 F 480.907.2286

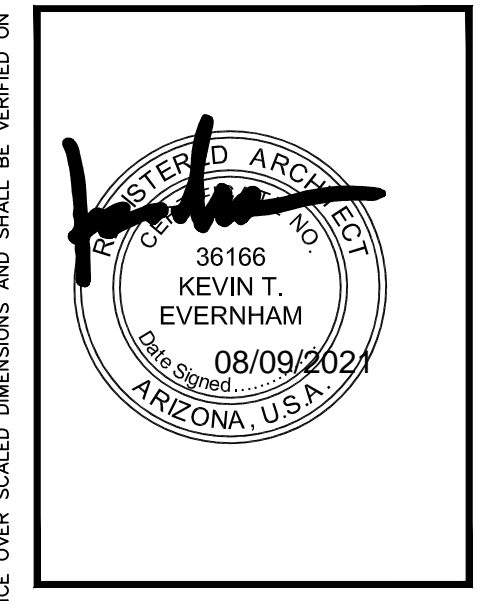

**SOSSAMAN 202 INDUSTRIAL PARK**  
 S. SOSSAMAN ROAD  
 MESA, ARIZONA

SITE PLAN	
DATE	REMARKS

PA / PM:	B. SANDSTROM
DRAWN BY:	D.V
JOB NO.:	PHX21-0009-00

SHEET  
**A1.4**

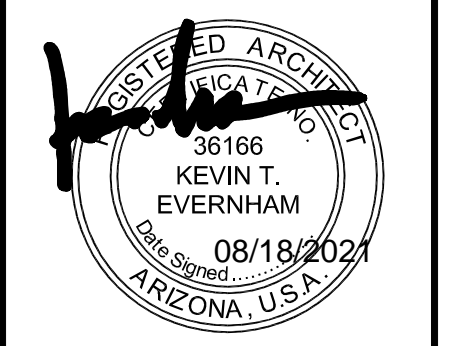

**SOSSAMAN 202 INDUSTRIAL PARK**  
S. SOSSAMAN ROAD  
MESA, ARIZONA

SITE WALL-SCREEN	
DATE	REMARKS

PA / PM: B. SANDSTROM  
DRAWN BY: DV  
JOB NO.: PHX21-0009-00

SHEET  
**A1.2**

W:\PHX\21\0009\000\Architectural\Cad\DD\PLANNING\0009\_A12\_Site\_Wall\_Acc\_P1\_SP3.1.dwg

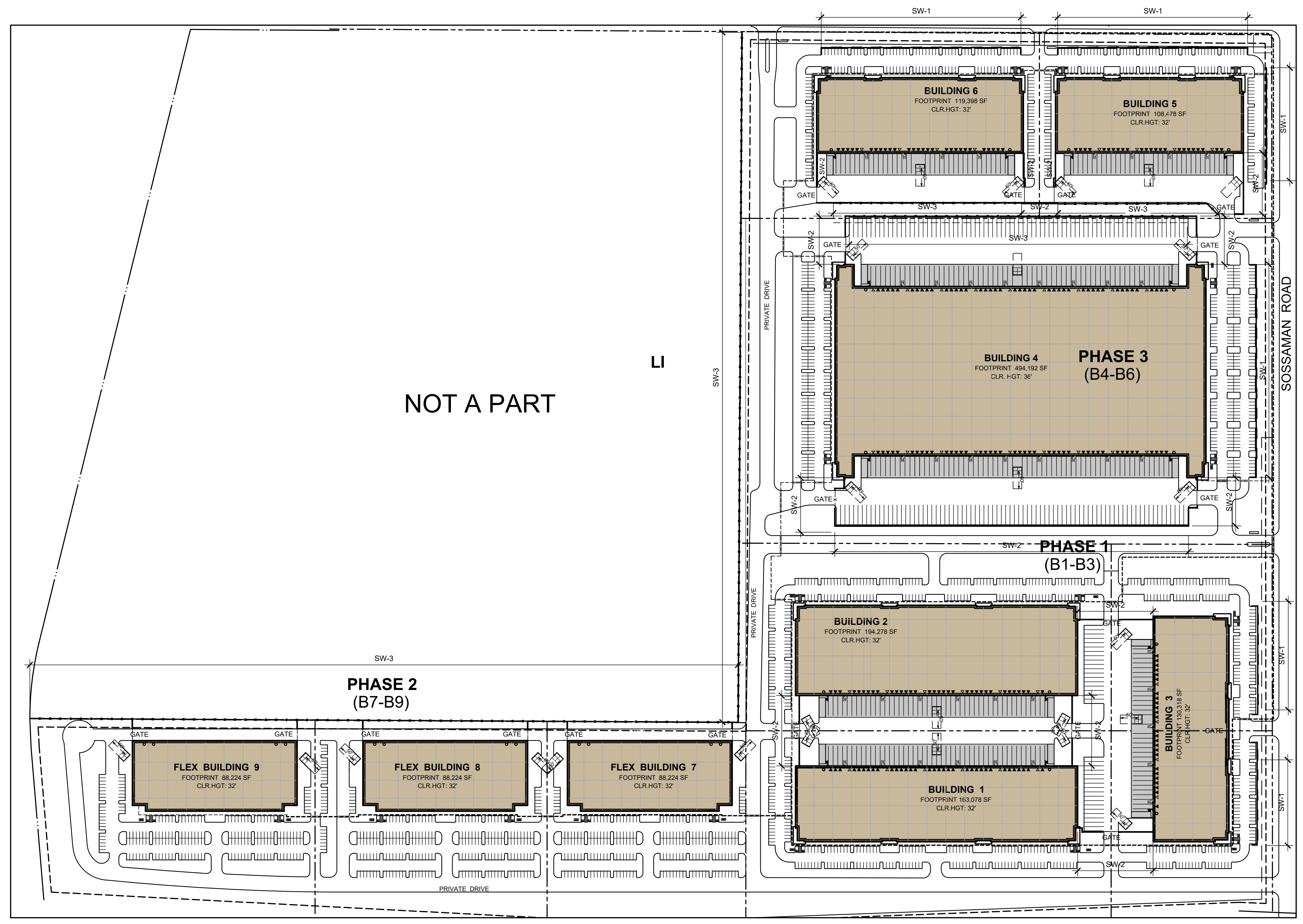

**SITE WALL LEGEND**

- 1** SW-1  
CMU PARKING SCREEN WALL
- 2** SW-2  
CMU TRUCK SCREEN WALL
- 3** SW-3  
IRON FENCE (INTERNAL)
- 10** GATE  
OPAQUE SLIDING METAL GATE
- A1.4** SITE WALKING ACCESS  
LANDSCAPE PATH BY OTHERS

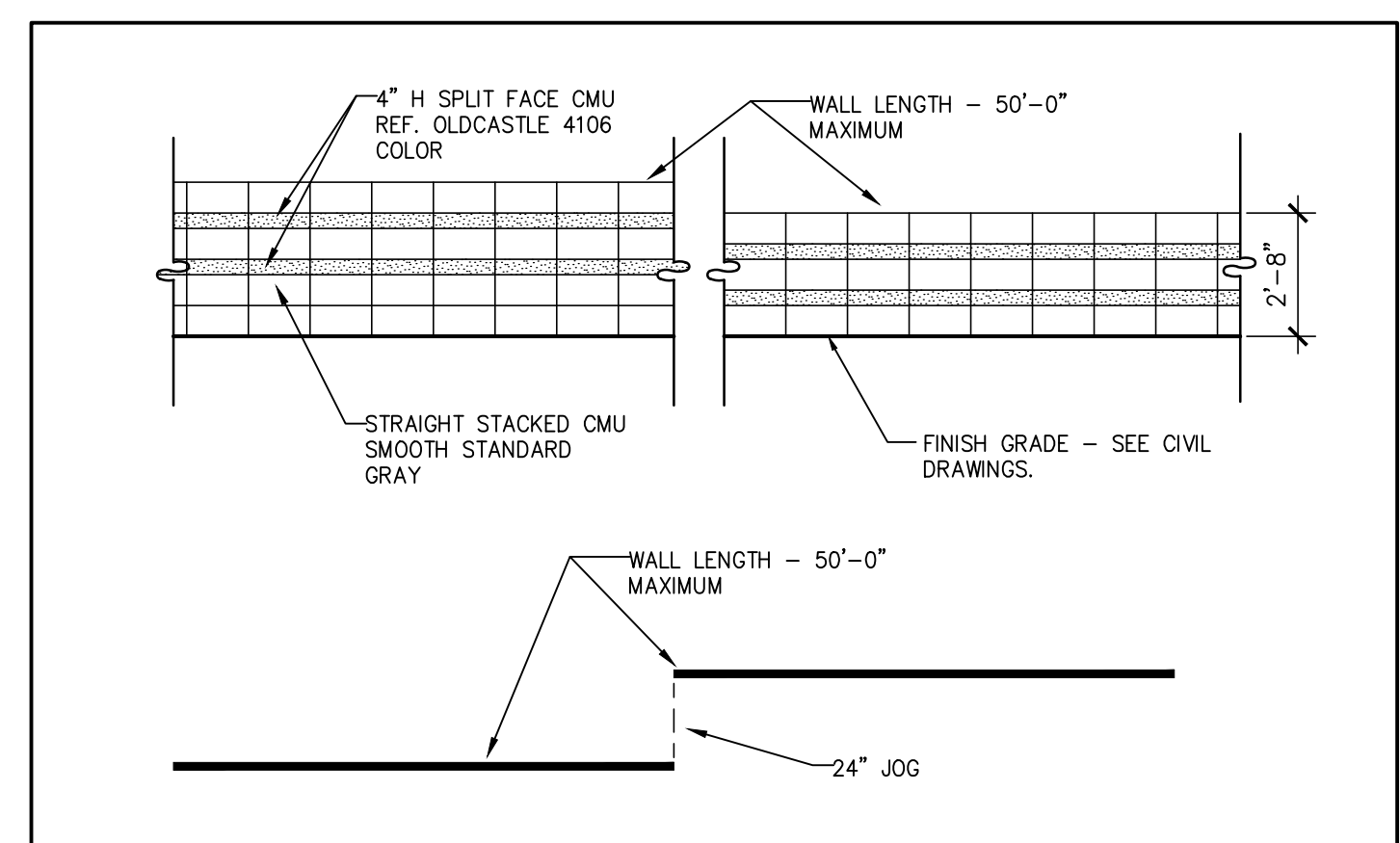
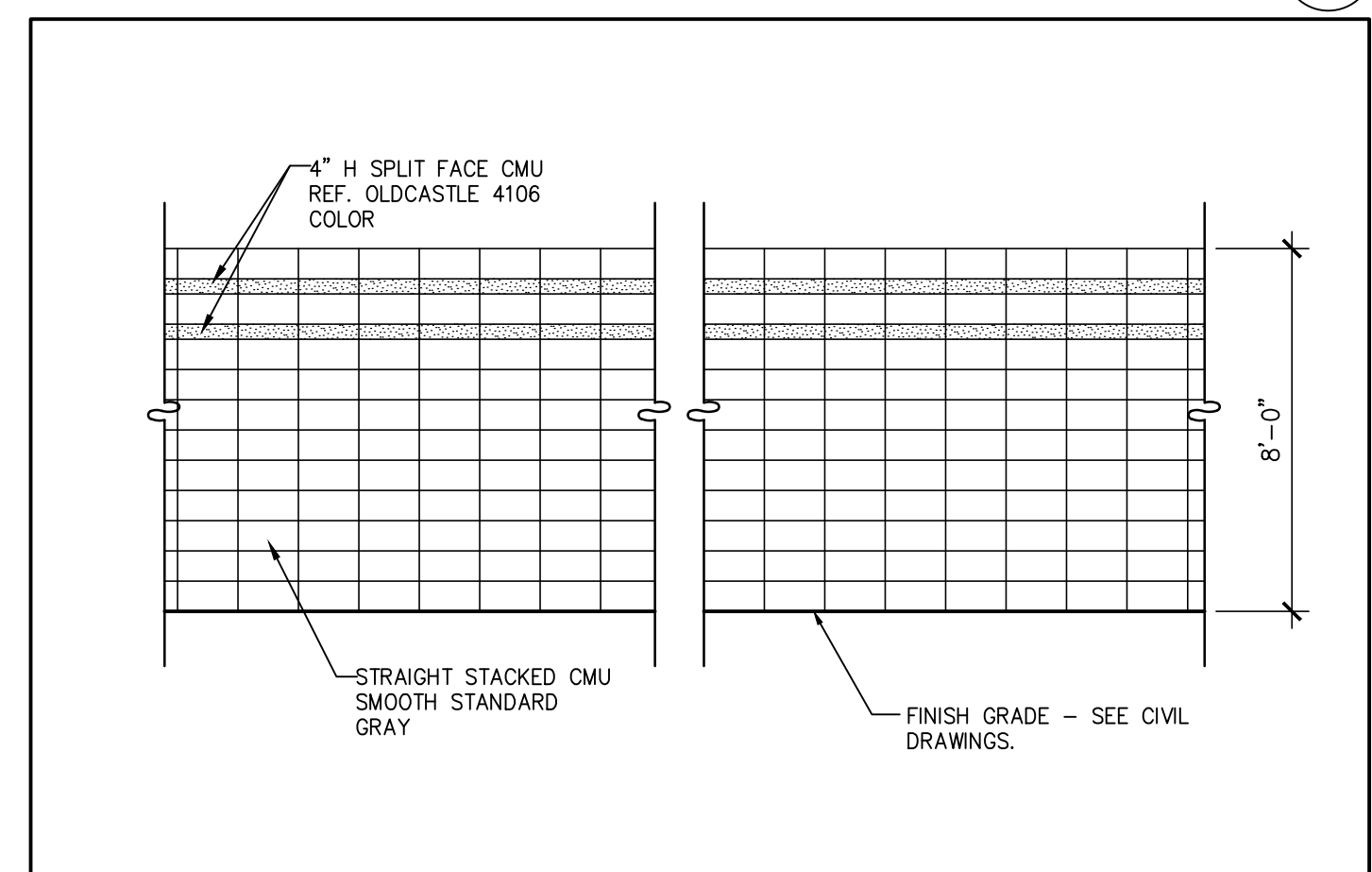
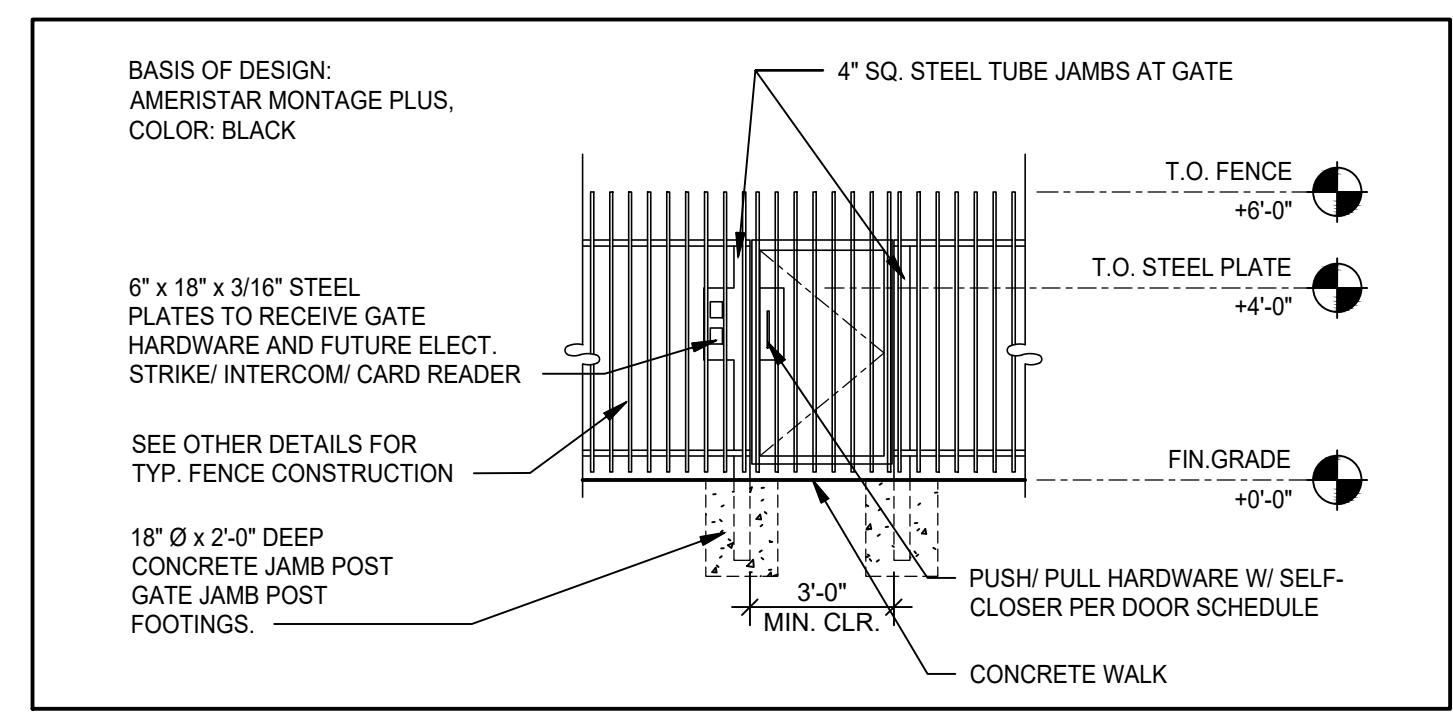

SOSSAMAN 202 SITE OPEN SPACE AREA CALCULATION	SQUARE FEET	ACRES	PERCENT COVERED / PROVIDED
BUILDING 1 COVERAGE	163,078.0	3.7	3.5
BUILDING 2 COVERAGE	194,278.0	4.5	4.2
BUILDING 3 COVERAGE	130,318.0	3.0	2.8
BUILDING 4 COVERAGE	494,192.0	11.3	10.7
BUILDING 5 COVERAGE	108,478.0	2.5	2.3
BUILDING 6 COVERAGE	119,398.0	2.7	2.6
BUILDING 7 COVERAGE	88,224.0	2.0	1.9
BUILDING 8 COVERAGE	88,224.0	2.0	1.9
BUILDING 9 COVERAGE	88,224.0	2.0	1.9
<b>TOTAL BUILDING AREA COVERAGE</b>	<b>1,474,414.0</b>	<b>33.8</b>	<b>31.8</b>
BUILDING 1 PLAZA AREA COVERAGE:	3,200.0	0.1	2.0
BUILDING 2 PLAZA AREA COVERAGE	4,320.0	0.1	2.2
BUILDING 3 PLAZA AREA COVERAGE	2,430.0	0.1	1.9
BUILDING 4 PLAZA AREA COVERAGE	13,260.0	0.3	2.7
BUILDING 5 PLAZA AREA COVERAGE	2,700.0	0.1	2.5
BUILDING 6 PLAZA AREA COVERAGE	1,755.0	0.0	1.5
BUILDING 7 PLAZA AREA COVERAGE	6,000.0	0.1	6.8
BUILDING 8 PLAZA AREA COVERAGE	6,000.0	0.1	6.8
BUILDING 9 PLAZA AREA COVERAGE	6,000.0	0.1	6.8
<b>TOTAL PLAZA AREA COVERAGE</b>	<b>45,665.0</b>	<b>1.0</b>	<b>3.1</b>

**MILL FINISH ALUMINUM  
BAR GRATING**

**WIDE FLANGE COLUMN AND BEAM  
STRUCTURE-POWDER  
COAT FINISH TO MATCH STOREFRONT  
GLAZING SYSTEM**



**OPEN SPACE/PLAZA PROTOTYPE**



**SITE TABLES**



**SITE REFUSE CONTAINER**



**SITE BIKE RACKS**



**SITE BENCHES**

**WARE MALCOMB**  
Leading Design for Commercial Real Estate

architecture  
planning  
interiors  
graphics  
civil engineering

2777 E. Camelback Rd, Suite 325  
Phoenix, AZ 85016  
P 480.767.1001  
F 480.947.2286

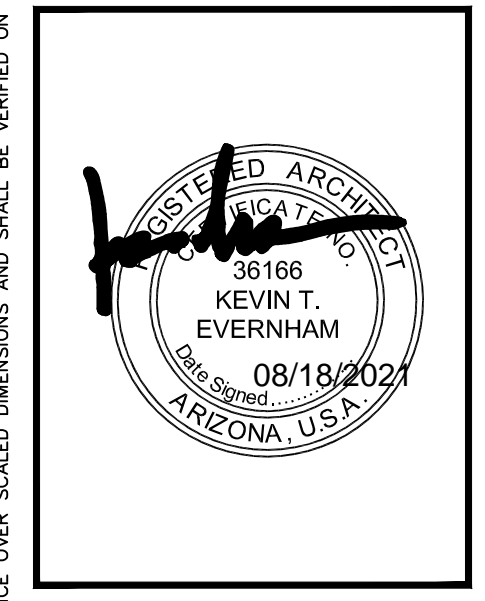

**SOSSAMAN 202  
INDUSTRIAL PARK**  
S. SOSSAMAN ROAD  
MESA, ARIZONA

SITE FURNISHINGS	
DATE	REMARKS

PA / PM:	B. SANDSTROM
DRAWN BY:	DV
JOB NO.:	PHX21-0009-00

SHEET  
**A1.6**

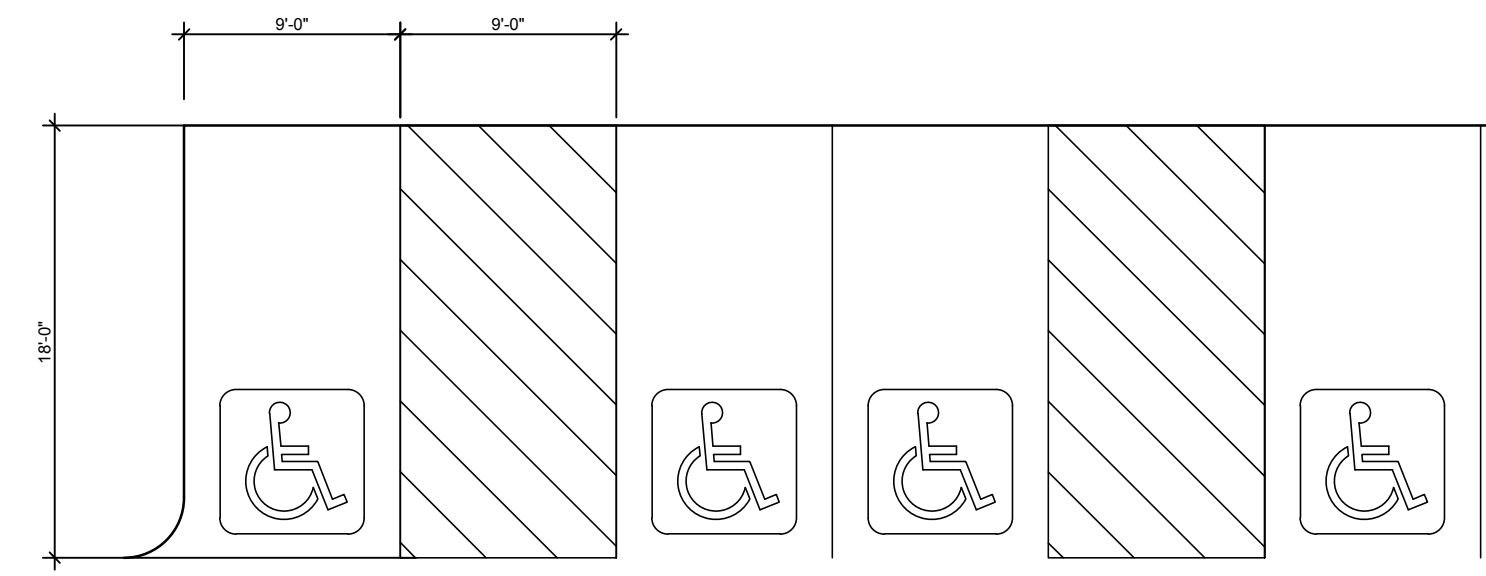

**ACCESIBLE PARKING DETAIL W/ DIM.**  
SCALE: 1/8" = 1'-0" **9**

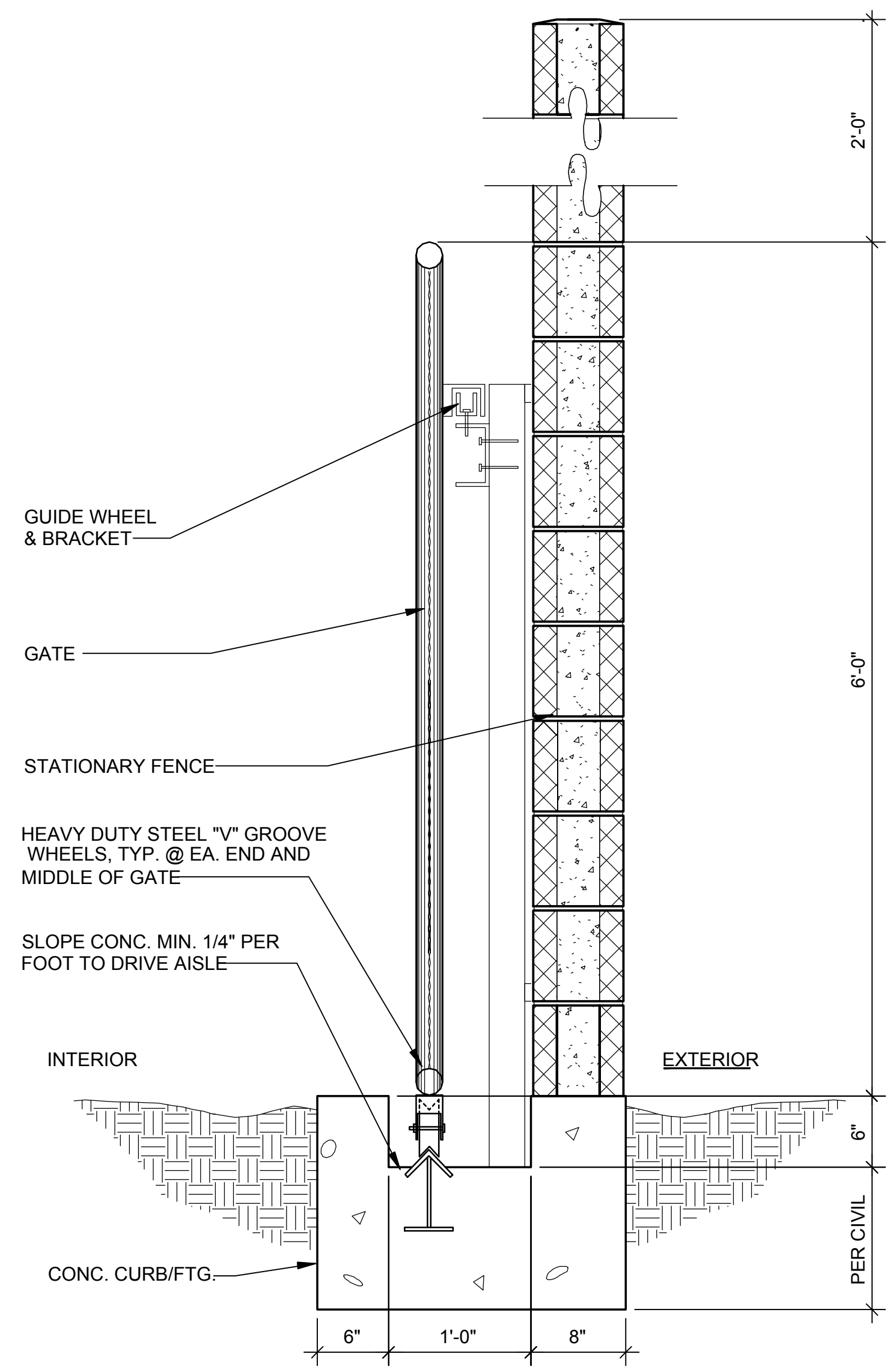

**SLIDING GATE - SECTION**  
SCALE: 1" = 1'-0" **10**

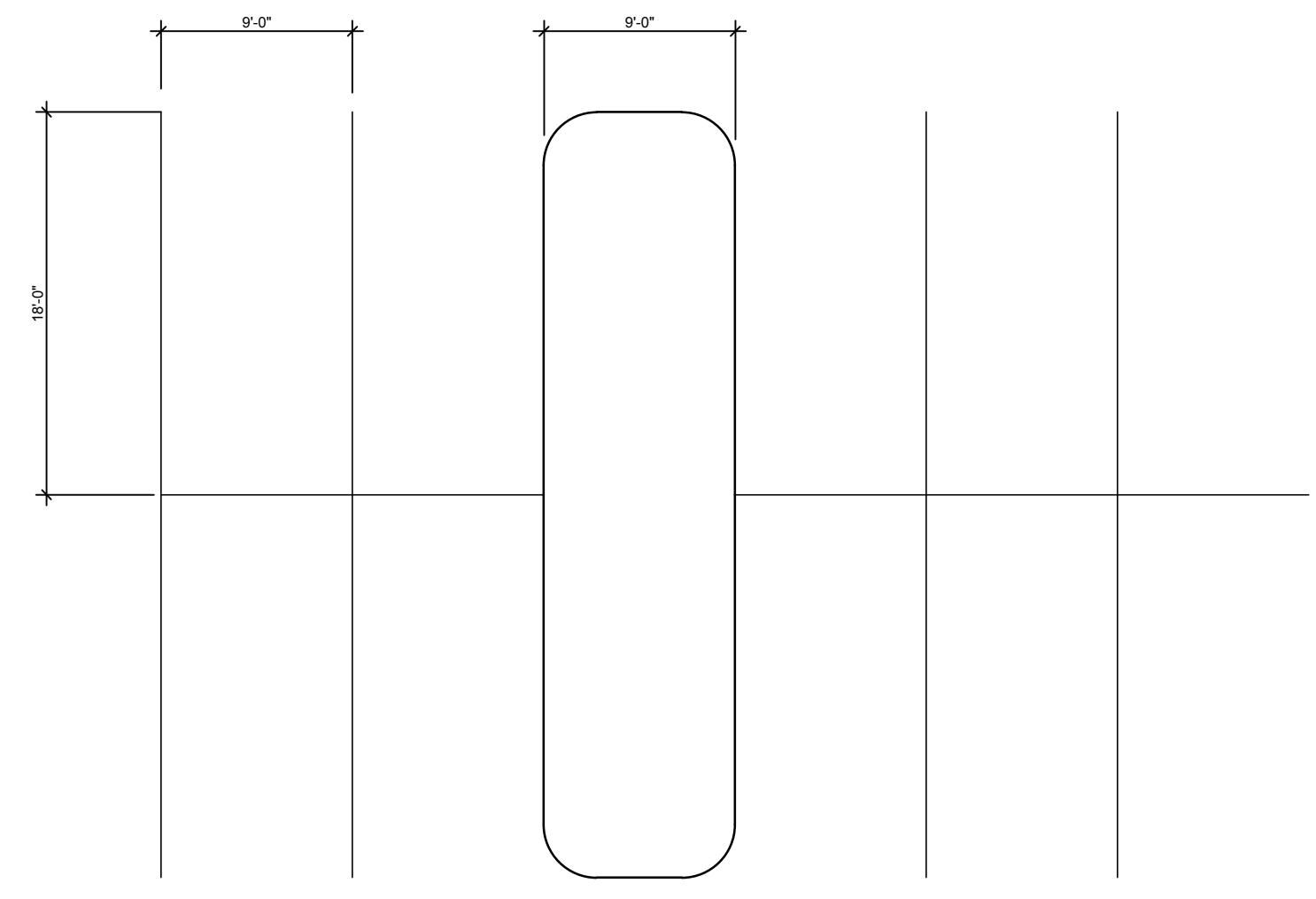

**STANDARD PARKING**  
SCALE: 1/8" = 1'-0" **10**

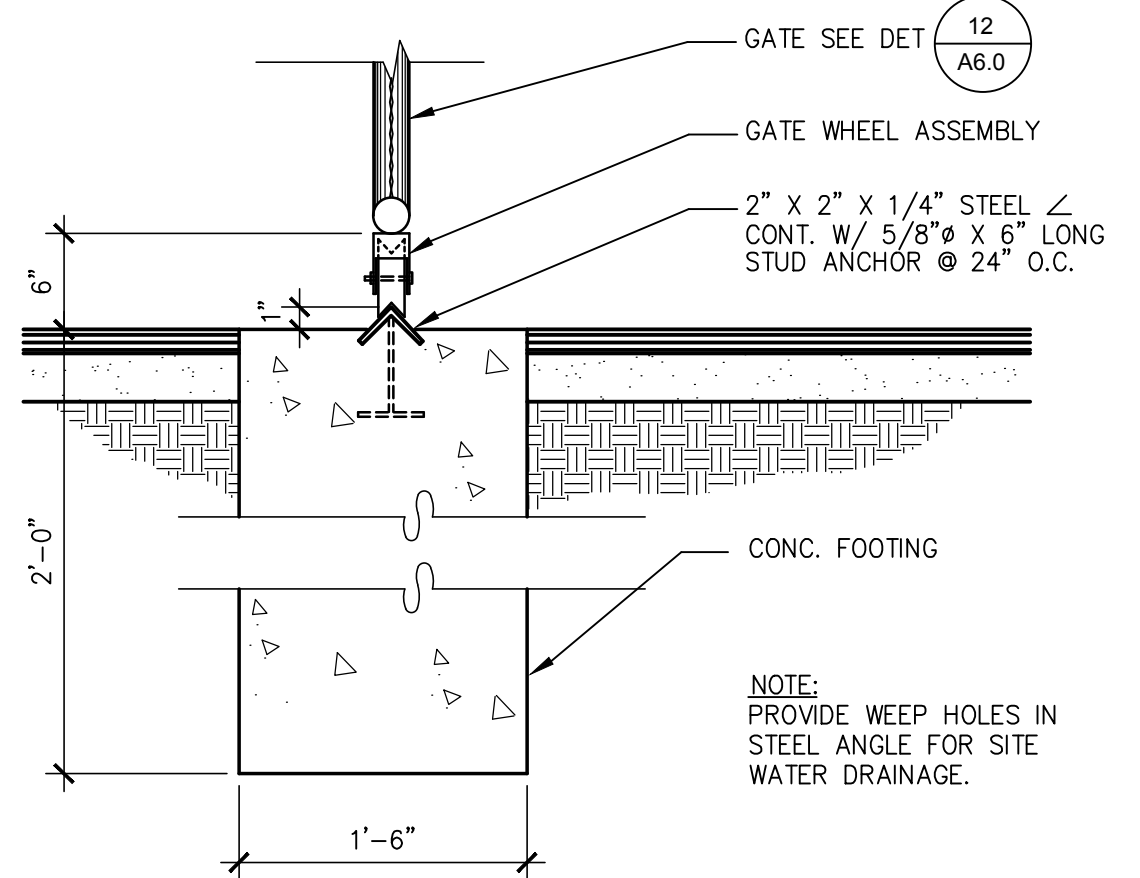

**SLIDING GATE - TRACK**  
SCALE: 3/4" = 1'-0" **8**

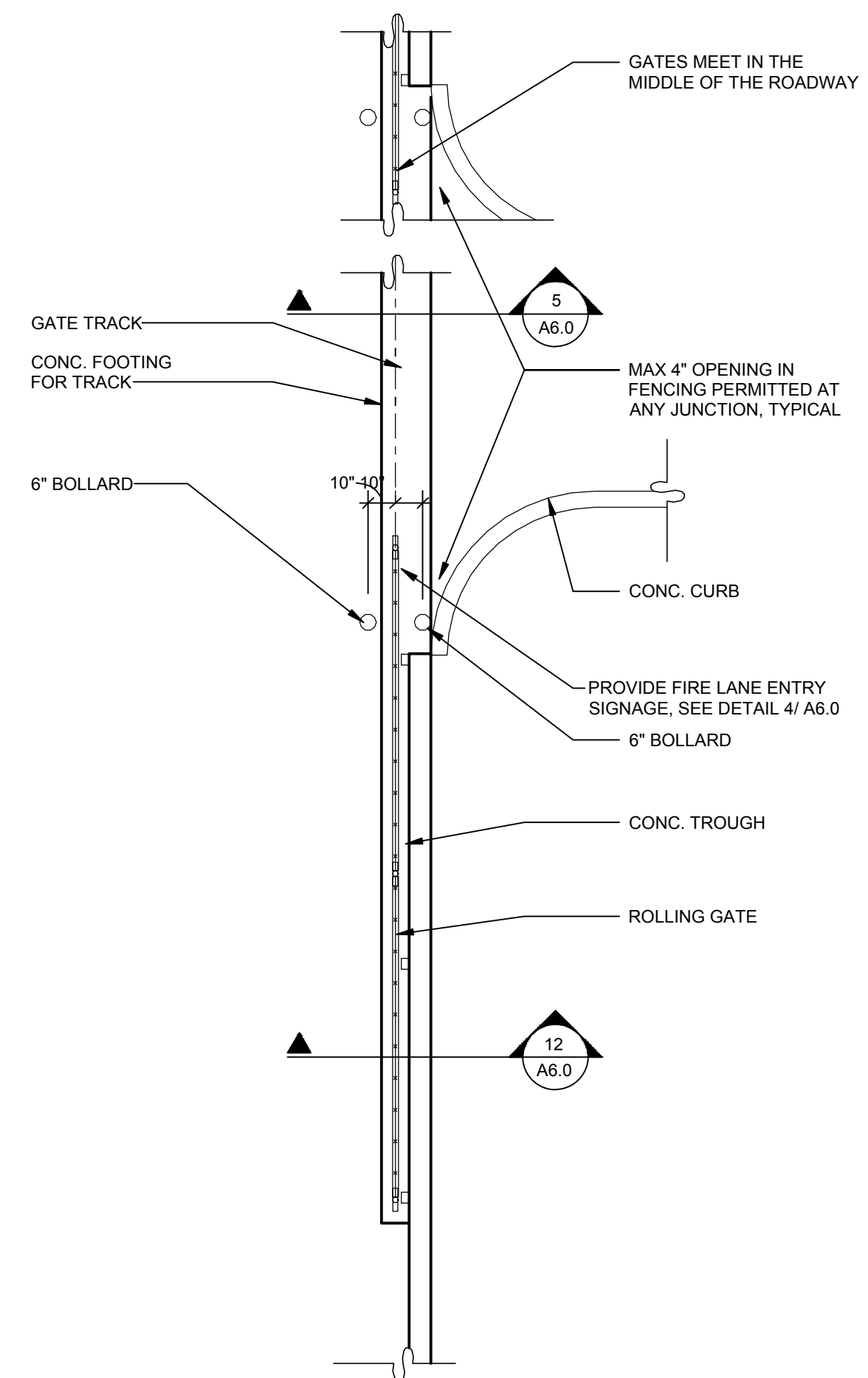

**SLIDING GATE - PLAN**  
SCALE: 1" = 1'-0" **7**

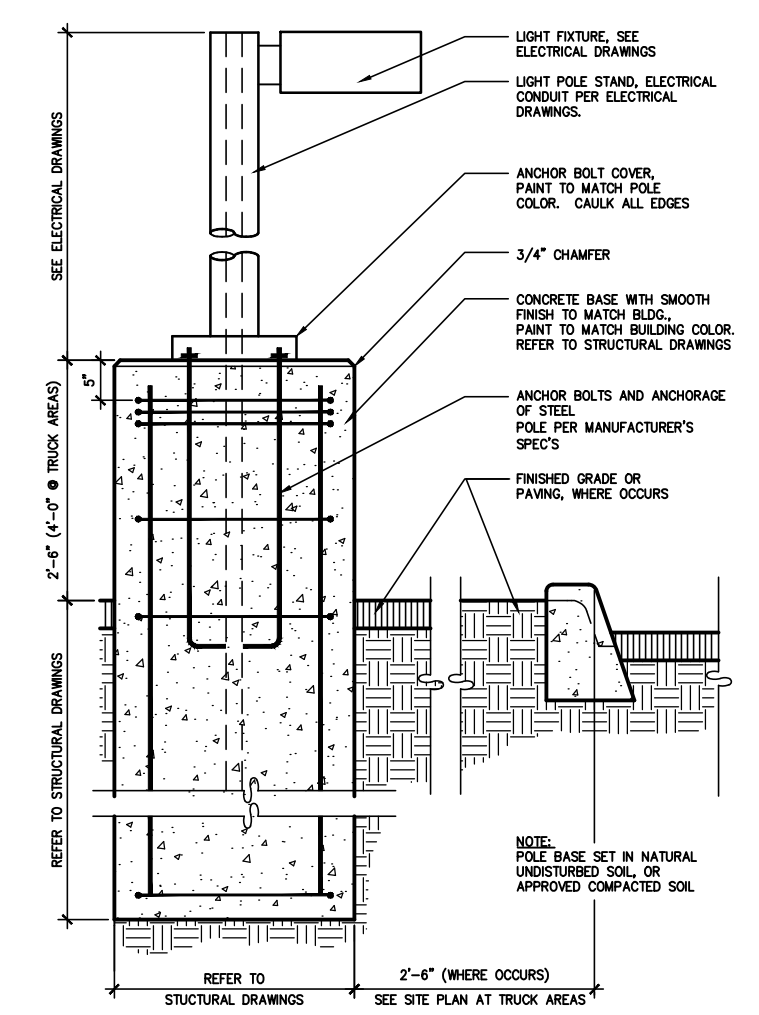

**LIGHT POLE BASE AND FOOTING**  
SCALE: 1/8" = 1'-0" **6**

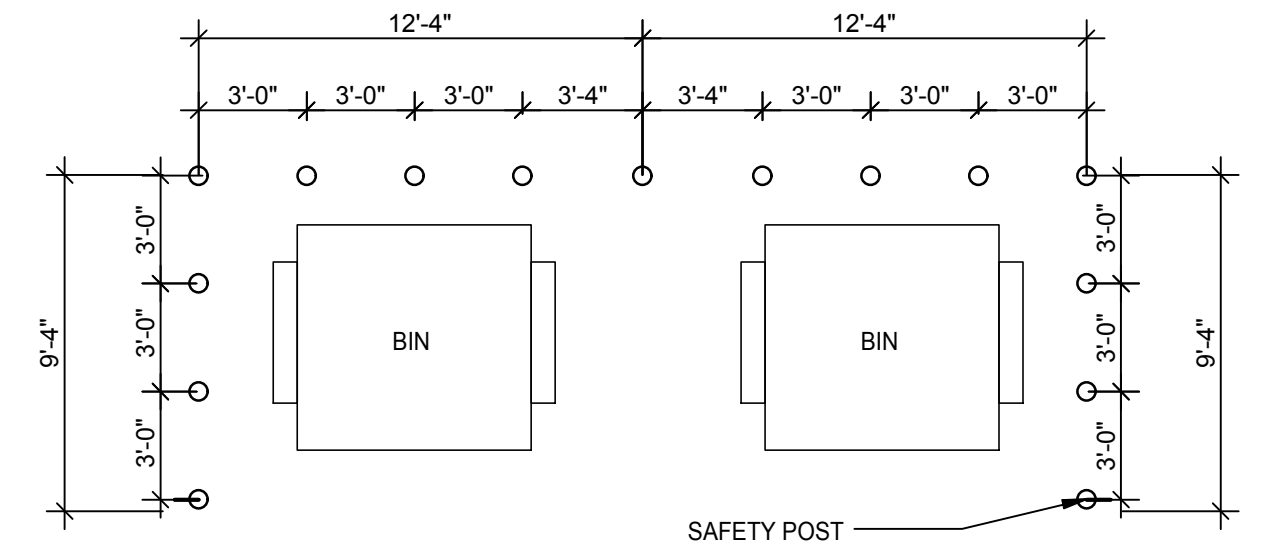

**BOLLARD BIN ENCLOSURE**  
SCALE: 3/16" = 1'-0" **5**

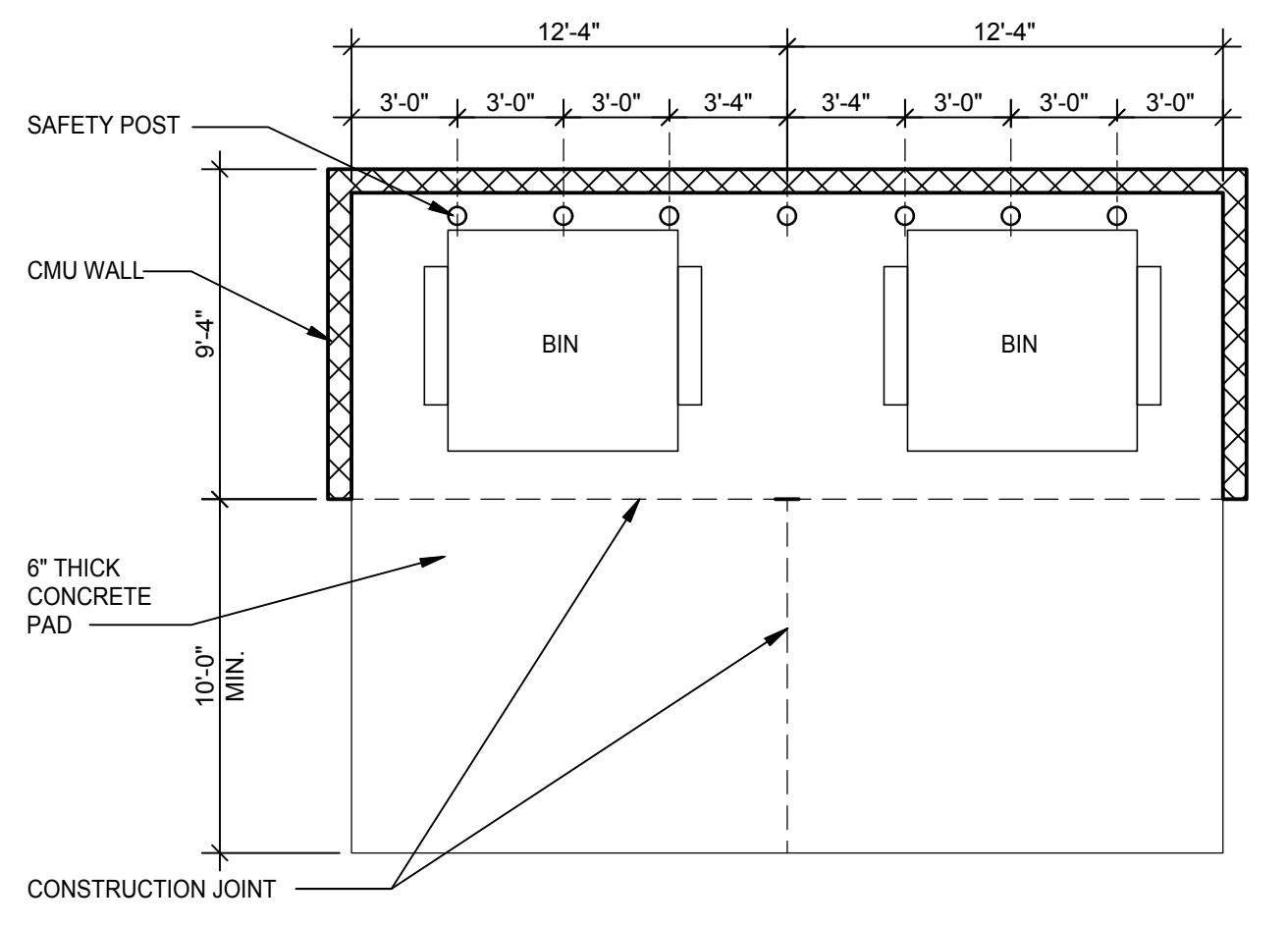

**DOUBLE WIDE BIN ENCLOSURE**  
SCALE: 3/16" = 1'-0" **4**

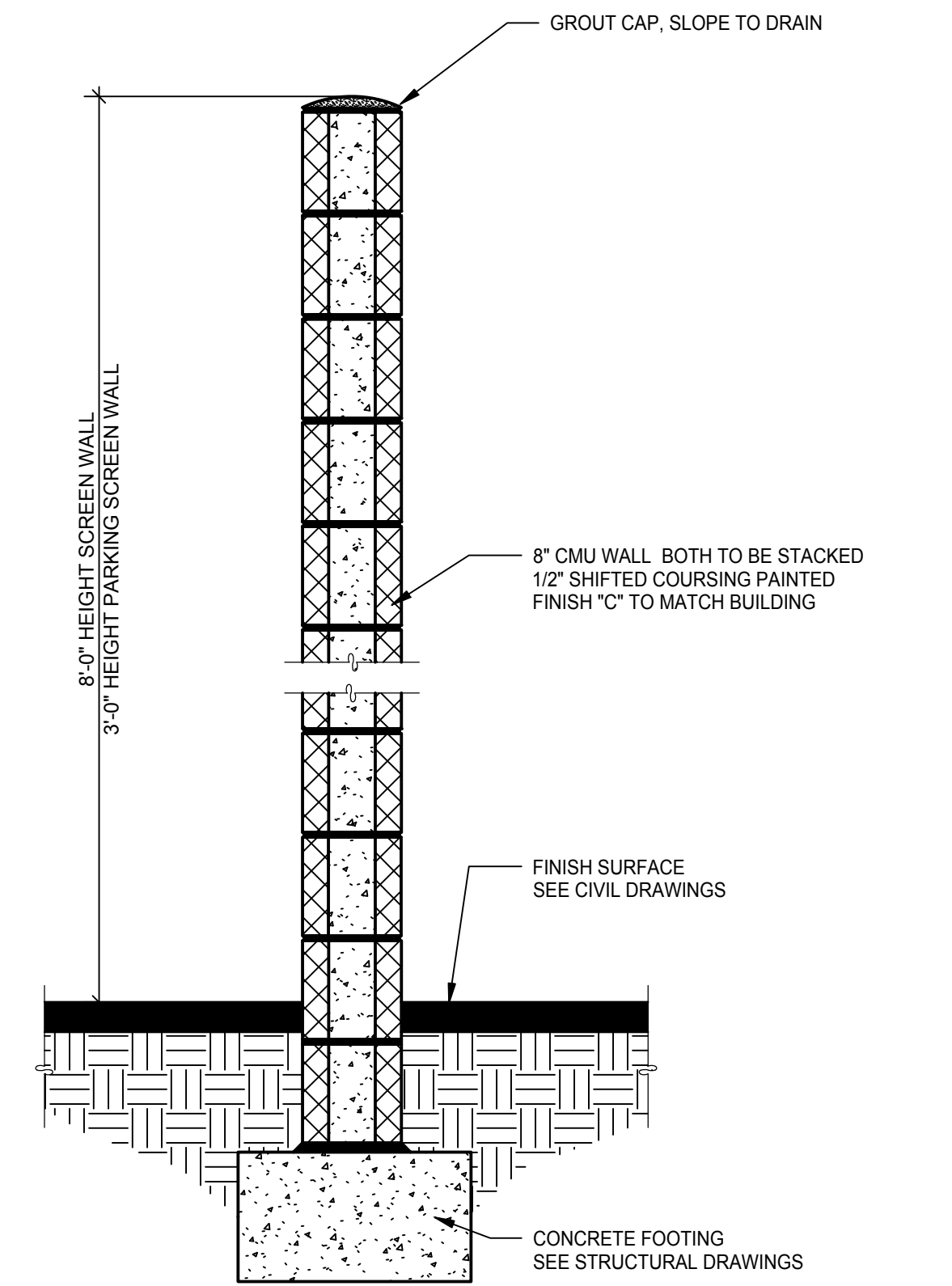

**MASONRY SCREEN WALL**  
SCALE: 1" = 1'-0" **2**

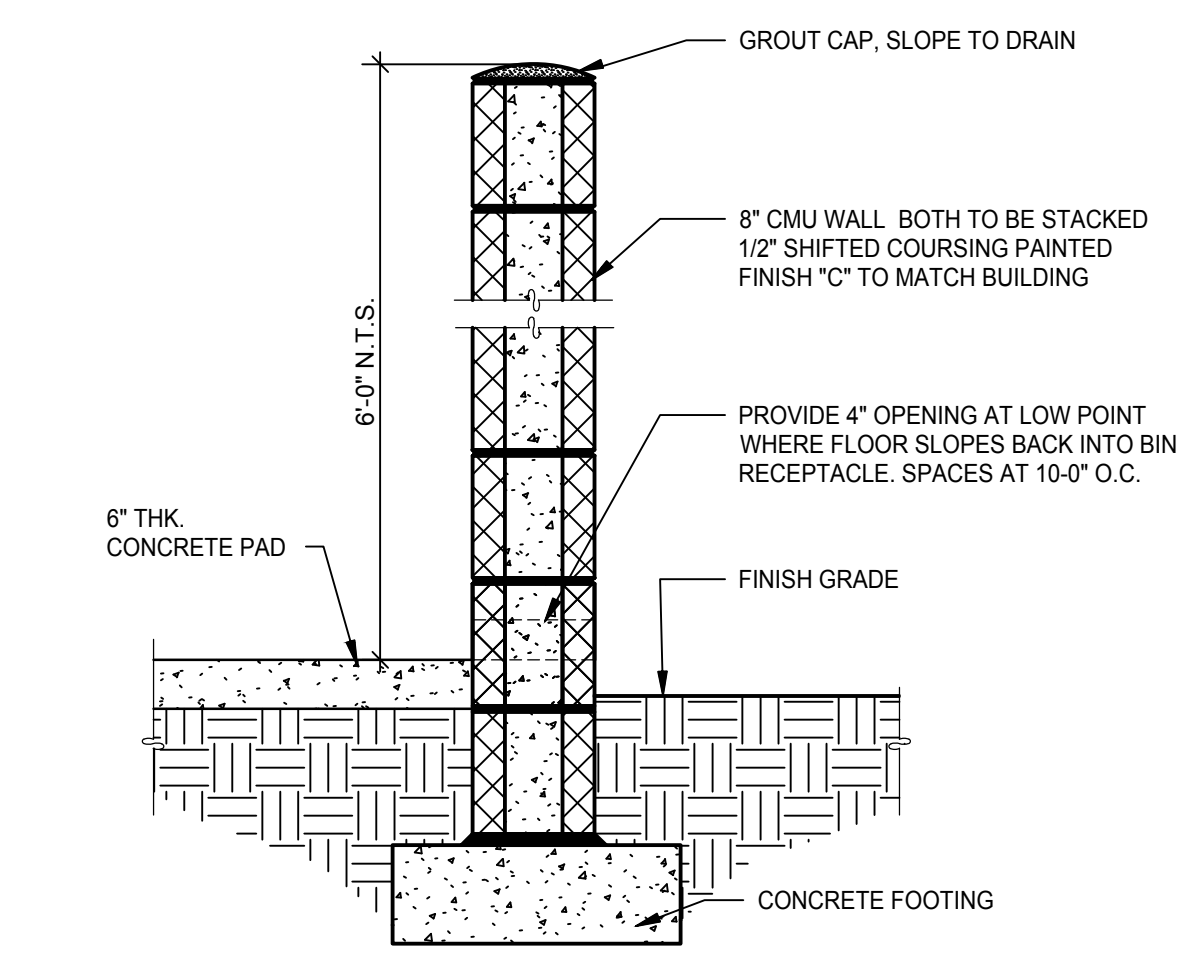

**MASONRY TRASH WALL**  
SCALE: 1" = 1'-0" **1**

**WARE MALCOMB**  
Leading Design for Commercial Real Estate

architecture  
planning  
interiors  
graphics  
civil engineering  
2777 E. Camelback Rd., Suite 325  
Phoenix, AZ 85016  
P 480.757.1001  
F 480.907.2286

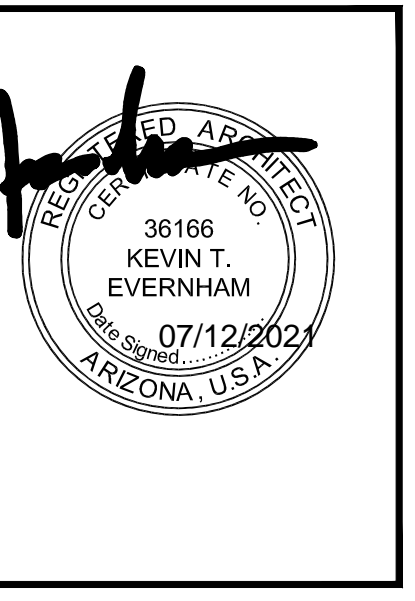

**SOSSAMAN 202 INDUSTRIAL PARK**  
S. SOSSAMAN ROAD  
MESA, ARIZONA

SITE DETAILS	
DATE	REMARKS

PA / PM: B. SANDSTROM  
DRAWN BY: CG  
JOB NO.: PHX21-0009-00

SHEET  
**A1.4**