

FRONT ELEVATION

	STUCCO - EGERT WHITE	STUCCO - STONEHENGE GREIGE	PLANK LAP SIDING - TIMBER BARK	BRICK VENEER	GLAZING
FRONT	27%	9%	32%	9%	23%
LEFT	67%	0%	24%	0%	9%
BACK	27%	9%	32%	9%	23%
RIGHT	67%	0%	24%	0%	9%

MATERIAL LEGEND	
NUMBER	MATERIAL
01	STUCCO - EGERT WHITE
02	STUCCO - STONEHENGE GREIGE
04	BRICK VENEER - BELDEN BRICK - TITANIUM VELOUR
06	PLANK LAP SIDING - TIMBER BARK



962 W 800 N, OREM, UT 84057
801.735.6314 | greg@legacyhomedesign.com
legacyhomedesign.com



3707 E. Southern Avenue
Mesa, AZ 85206
Phone: 480.734.1446

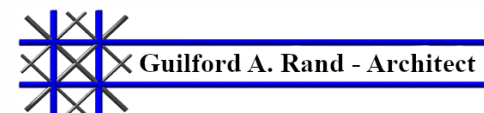

962 W 800 N, OREM, UT 84057
801.362.0343 | archcoalition@hotmail.com

BFH GROUP
COUNTRY CLUB - 20-PLEX
MESA, AZ

SQUARE FOOTAGE

UNITS		BUILDING	
ONE BEDROOM	712 SF	MAIN LEVEL	6997 SF
TWO BEDROOMS	847 SF	SECOND LEVEL	6997 SF
THREE BEDROOMS	1092 SF	THIRD LEVEL	6997 SF
		TOTAL	20990 SF

3/08/2024

A1



BACK ELEVATION



RIGHT ELEVATION

MATERIAL LEGEND	
NUMBER	MATERIAL
01	STUCCO - EGERT WHITE
02	STUCCO - STONEHENGE GREIGE
04	BRICK VENEER - BELDEN BRICK - TITANIUM VELOUR
06	PLANK LAP SIDING - TIMBER BARK



LEFT ELEVATION



962 W 800 N, OREM, UT 84057
801.735.6314 | greg@legacyhomedesign.com
legacyhomedesign.com



3707 E. Southern Avenue
Mesa, AZ 85206
Phone: 480.734.1446

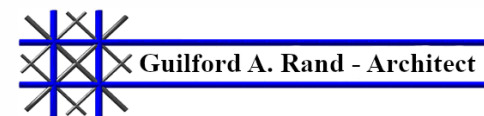

962 W 800 N, OREM, UT 84057
801.362.0343 | archcoalition@hotmail.com

BFH GROUP
COUNTRY CLUB - 20-PLEX
MESA, AZ

SQUARE FOOTAGE

UNITS		BUILDING	
ONE BEDROOM	712 SF	MAIN LEVEL	6997 SF
TWO BEDROOMS	847 SF	SECOND LEVEL	6997 SF
THREE BEDROOMS	1092 SF	THIRD LEVEL	6997 SF
		TOTAL	20990 SF

3/08/2024

A2



MAIN LEVEL



962 W 800 N, OREM, UT 84057
 801.735.6314 | greg@legacyhomedesign.com
 legacyhomedesign.com



3707 E. Southern Avenue
 Mesa, AZ 85206
 Phone: 480.734.1446

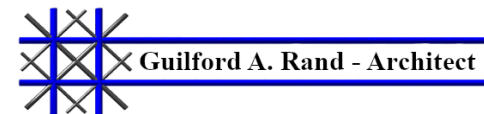

962 W 800 N, OREM, UT 84057
 801.362.0343 | archcoalition@hotmail.com

BFH GROUP
COUNTRY CLUB - 20-PLEX
 MESA, AZ

SQUARE FOOTAGE

UNITS		BUILDING	
ONE BEDROOM	712 SF	MAIN LEVEL	6997 SF
TWO BEDROOMS	847 SF	SECOND LEVEL	6997 SF
THREE BEDROOMS	1092 SF	THIRD LEVEL	6997 SF
		TOTAL	20990 SF

3/08/2024

A3



SECOND LEVEL



962 W 800 N, OREM, UT 84057
801.735.6314 | greg@legacyhomedesign.com
legacyhomedesign.com



3707 E. Southern Avenue
Mesa, AZ 85206
Phone: 480.734.1446

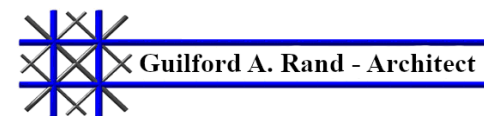

962 W 800 N, OREM, UT 84057
801.362.0343 | archcoalition@hotmail.com

BFH GROUP
COUNTRY CLUB - 20-PLEX
MESA, AZ

SQUARE FOOTAGE

UNITS		BUILDING	
ONE BEDROOM	712 SF	MAIN LEVEL	6997 SF
TWO BEDROOMS	847 SF	SECOND LEVEL	6997 SF
THREE BEDROOMS	1092 SF	THIRD LEVEL	6997 SF
		TOTAL	20990 SF

3/08/2024

A4



THIRD LEVEL



962 W 800 N, OREM, UT 84057
801.735.6314 | greg@legacyhomedesign.com
legacyhomedesign.com



3707 E. Southern Avenue
Mesa, AZ 85206
Phone: 480.734.1446

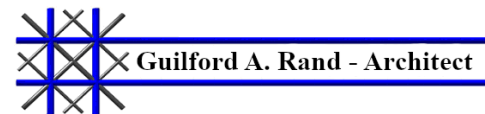

962 W 800 N, OREM, UT 84057
801.362.0343 | archcoalition@hotmail.com

BFH GROUP
COUNTRY CLUB - 20-PLEX
MESA, AZ

SQUARE FOOTAGE

UNITS		BUILDING	
ONE BEDROOM	712 SF	MAIN LEVEL	6997 SF
TWO BEDROOMS	847 SF	SECOND LEVEL	6997 SF
THREE BEDROOMS	1092 SF	THIRD LEVEL	6997 SF
		TOTAL	20990 SF

3/08/2024

A5

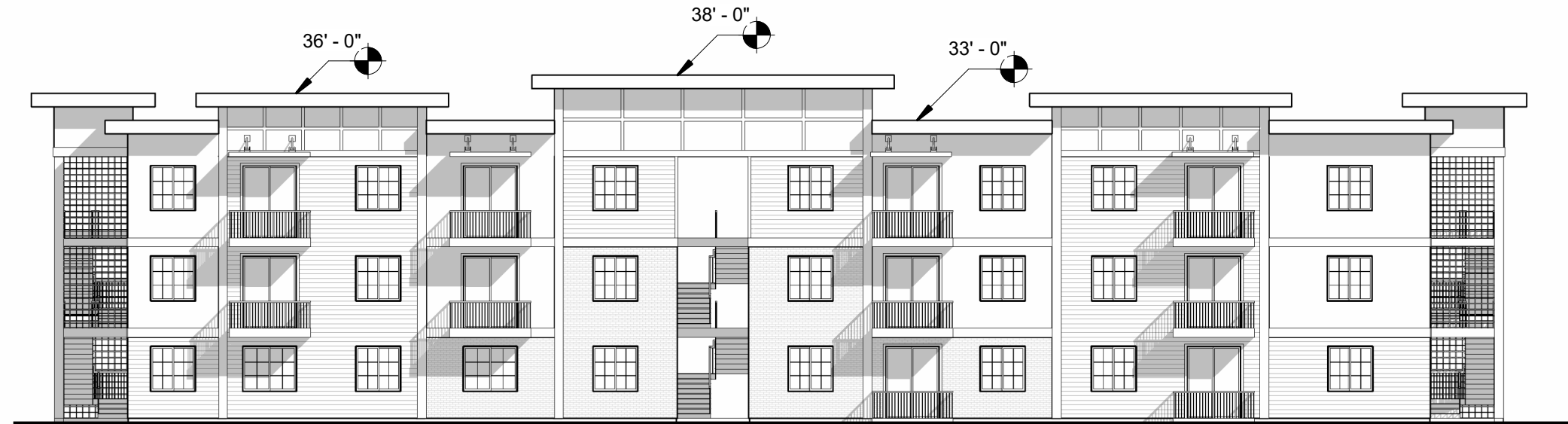

FRONT ELEVATION



RIGHT ELEVATION



962 W 800 N, OREM, UT 84057
801.735.6314 | greg@legacyhomedesign.com
legacyhomedesign.com



3707 E. Southern Avenue
Mesa, AZ 85206
Phone: 480.734.1446

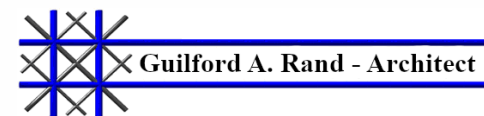

962 W 800 N, OREM, UT 84057
801.362.0343 | archcoalition@hotmail.com

BFH GROUP
COUNTRY CLUB - 20-PLEX
MESA, AZ

SQUARE FOOTAGE

UNITS		BUILDING	
ONE BEDROOM	712 SF	MAIN LEVEL	6997 SF
TWO BEDROOMS	847 SF	SECOND LEVEL	6997 SF
THREE BEDROOMS	1092 SF	THIRD LEVEL	6997 SF
		TOTAL	20990 SF

3/08/2024

A6



BACK ELEVATION

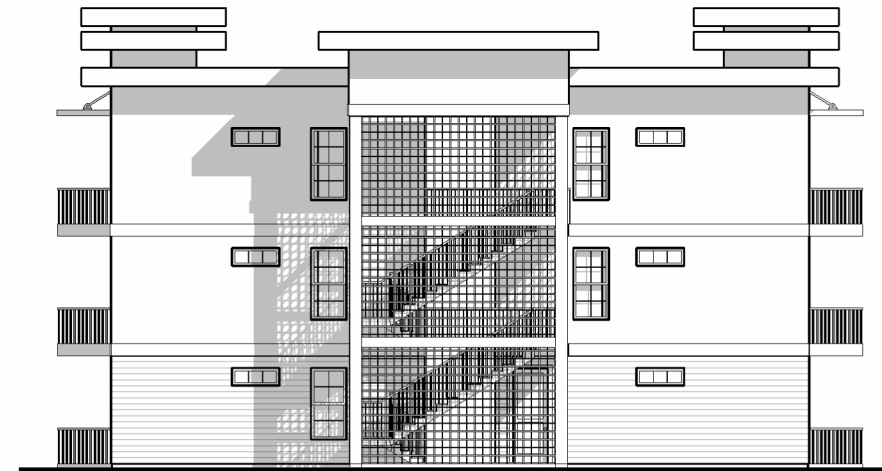

LEFT ELEVATION



962 W 800 N, OREM, UT 84057
801.735.6314 | greg@legacyhomedesign.com
legacyhomedesign.com



3707 E. Southern Avenue
Mesa, AZ 85206
Phone: 480.734.1446

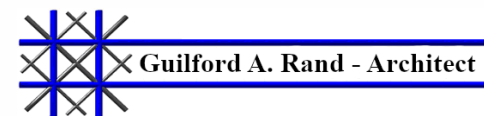

962 W 800 N, OREM, UT 84057
801.362.0343 | archcoalition@hotmail.com

BFH GROUP
COUNTRY CLUB - 20-PLEX
MESA, AZ

SQUARE FOOTAGE

UNITS		BUILDING	
ONE BEDROOM	712 SF	MAIN LEVEL	6997 SF
TWO BEDROOMS	847 SF	SECOND LEVEL	6997 SF
THREE BEDROOMS	1092 SF	THIRD LEVEL	6997 SF
		TOTAL	20990 SF

3/08/2024

A7



FRONT ELEVATION

	STUCCO - EGERT WHITE	STUCCO - STONEHENGE GREIGE	PLANK LAP SIDING - TIMBER BARK	BRICK VENEER	GLAZING
FRONT	35%	6%	23%	12%	24%
LEFT	67%	0%	23%	0%	9%
BACK	35%	6%	23%	12%	24%
RIGHT	67%	0%	23%	0%	9%

MATERIAL LEGEND	
NUMBER	MATERIAL
01	STUCCO - EGERT WHITE
02	STUCCO - STONEHENGE GREIGE
04	BRICK VENEER - BELDEN BRICK - TITANIUM VELOUR
06	PLANK LAP SIDING - TIMBER BARK



962 W 800 N, OREM, UT 84057
801.735.6314 | greg@legacyhomedesign.com
legacyhomedesign.com



3707 E. Southern Avenue
Mesa, AZ 85206
Phone: 480.734.1446

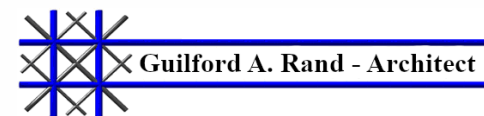

962 W 800 N, OREM, UT 84057
801.362.0343 | archcoalition@hotmail.com

BFH GROUP
COUNTRY CLUB - 36-PLEX
MESA, AZ

SQUARE FOOTAGE

UNITS		BUILDING	
ONE BEDROOM	695 SF	MAIN LEVEL	12422 SF
TWO BEDROOMS	845 SF	SECOND LEVEL	12422 SF
THREE BEDROOMS	1092 SF	THIRD LEVEL	12422 SF
		TOTAL	37265 SF

3/08/2024

A1



BACK ELEVATION



RIGHT ELEVATION

MATERIAL LEGEND	
NUMBER	MATERIAL
01	STUCCO - EGERT WHITE
02	STUCCO - STONEHENGE GREIGE
04	BRICK VENEER - BELDEN BRICK - TITANIUM VELOUR
06	PLANK LAP SIDING - TIMBER BARK

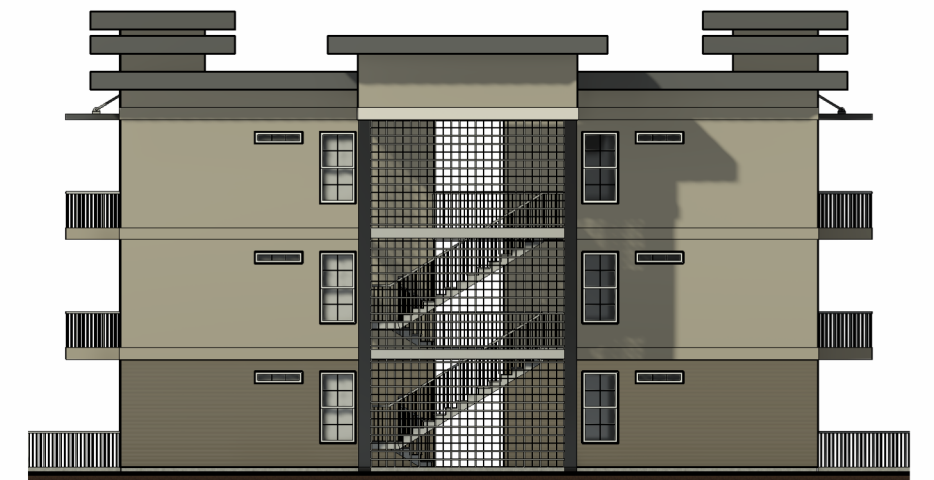

LEFT ELEVATION



962 W 800 N, OREM, UT 84057
801.735.6314 | greg@legacyhomedesign.com
legacyhomedesign.com



3707 E. Southern Avenue
Mesa, AZ 85206
Phone: 480.734.1446

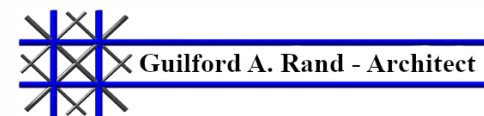

962 W 800 N, OREM, UT 84057
801.362.0343 | archcoalition@hotmail.com

BFH GROUP
COUNTRY CLUB - 36-PLEX
MESA, AZ

SQUARE FOOTAGE

UNITS		BUILDING	
ONE BEDROOM	695 SF	MAIN LEVEL	12422 SF
TWO BEDROOMS	845 SF	SECOND LEVEL	12422 SF
THREE BEDROOMS	1092 SF	THIRD LEVEL	12422 SF
		TOTAL	37265 SF

3/08/2024

A2



MAIN LEVEL



962 W 800 N, OREM, UT 84057
801.735.6314 | greg@legacyhomedesign.com
legacyhomedesign.com



3707 E. Southern Avenue
Mesa, AZ 85206
Phone: 480.734.1446

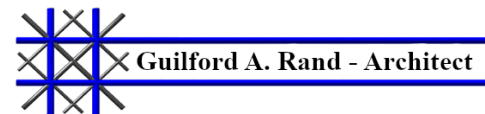

962 W 800 N, OREM, UT 84057
801.362.0343 | archcoalition@hotmail.com

BFH GROUP
COUNTRY CLUB - 36-PLEX
MESA, AZ

SQUARE FOOTAGE

UNITS		BUILDING	
ONE BEDROOM	695 SF	MAIN LEVEL	12422 SF
TWO BEDROOMS	845 SF	SECOND LEVEL	12422 SF
THREE BEDROOMS	1092 SF	THIRD LEVEL	12422 SF
		TOTAL	37265 SF

3/08/2024

A3

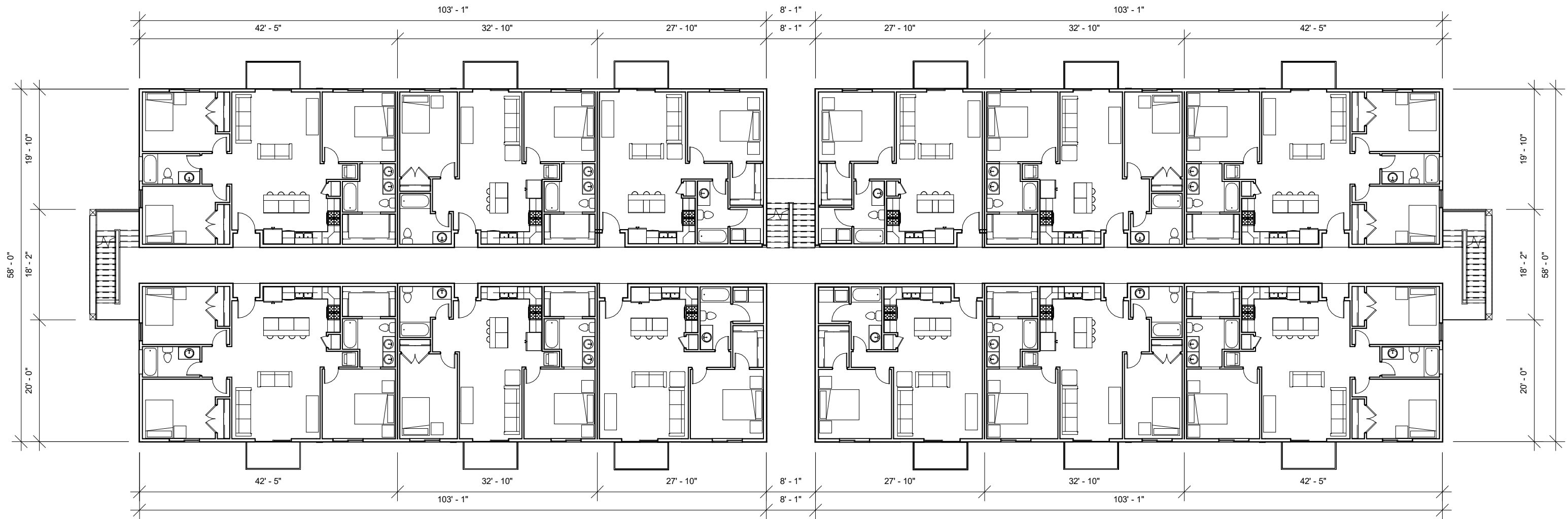

SECOND LEVEL



962 W 800 N, OREM, UT 84057
801.735.6314 | greg@legacyhomedesign.com
legacyhomedesign.com



3707 E. Southern Avenue
Mesa, AZ 85206
Phone: 480.734.1446

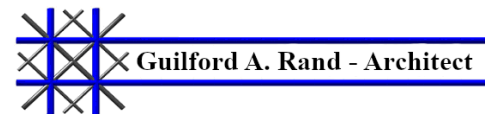

962 W 800 N, OREM, UT 84057
801.362.0343 | archcoalition@hotmail.com

BFH GROUP
COUNTRY CLUB - 36-PLEX
MESA, AZ

SQUARE FOOTAGE

UNITS		BUILDING	
ONE BEDROOM	695 SF	MAIN LEVEL	12422 SF
TWO BEDROOMS	845 SF	SECOND LEVEL	12422 SF
THREE BEDROOMS	1092 SF	THIRD LEVEL	12422 SF
		TOTAL	37265 SF

3/08/2024

A4

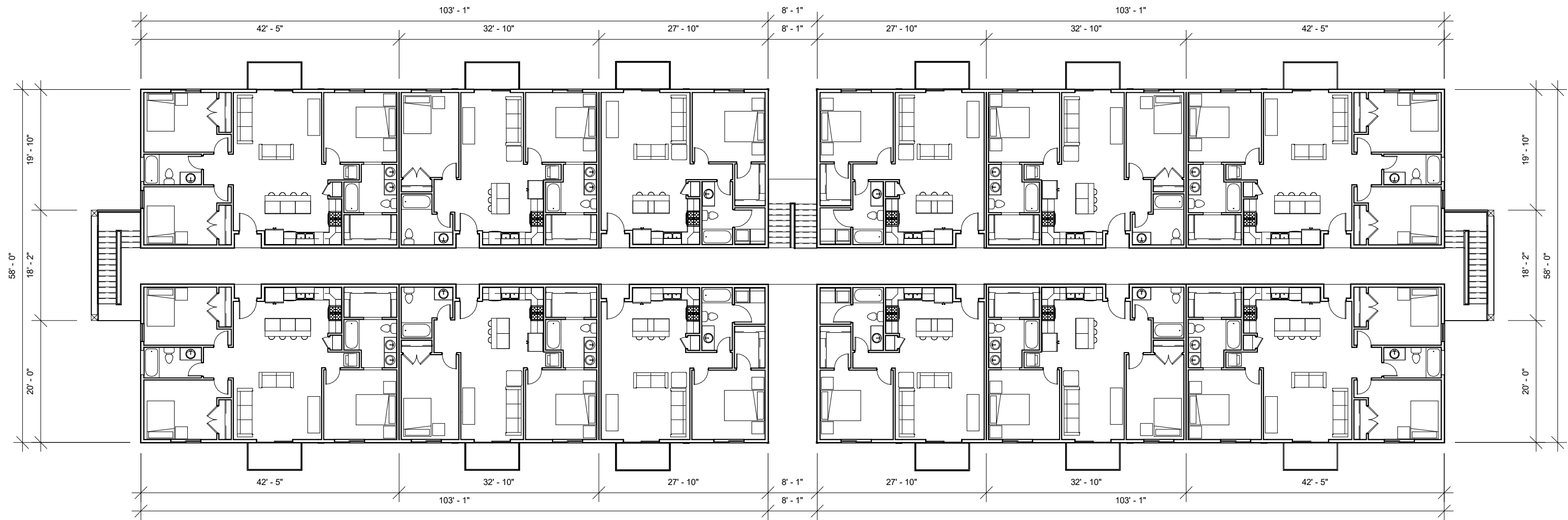

THIRD LEVEL



962 W 800 N, OREM, UT 84057
 801.735.6314 | greg@legacyhomedesign.com
 legacyhomedesign.com



3707 E. Southern Avenue
 Mesa, AZ 85206
 Phone: 480.734.1446

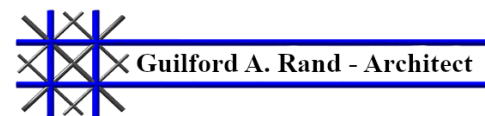

962 W 800 N, OREM, UT 84057
 801.362.0343 | archcoalition@hotmail.com

BFH GROUP
COUNTRY CLUB - 36-PLEX
MESA, AZ

SQUARE FOOTAGE

UNITS		BUILDING	
ONE BEDROOM	695 SF	MAIN LEVEL	12422 SF
TWO BEDROOMS	845 SF	SECOND LEVEL	12422 SF
THREE BEDROOMS	1092 SF	THIRD LEVEL	12422 SF
		TOTAL	37265 SF

3/08/2024

A5

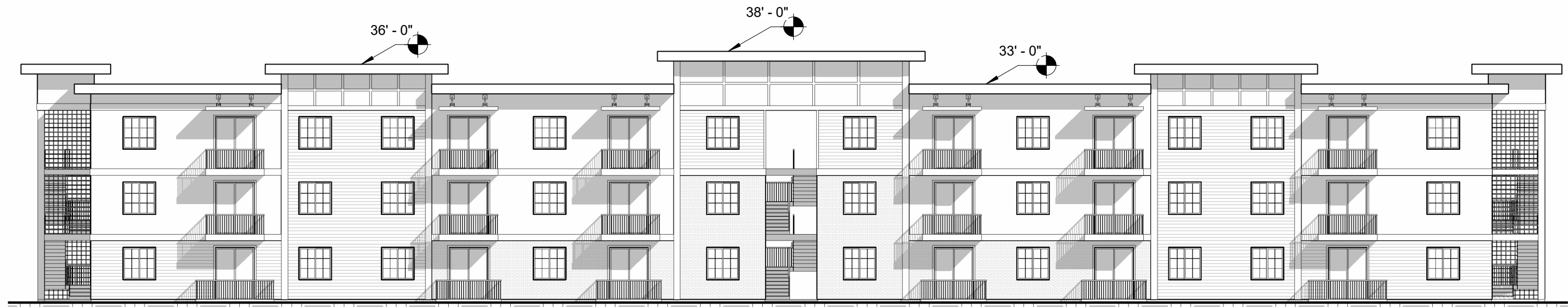

FRONT ELEVATION

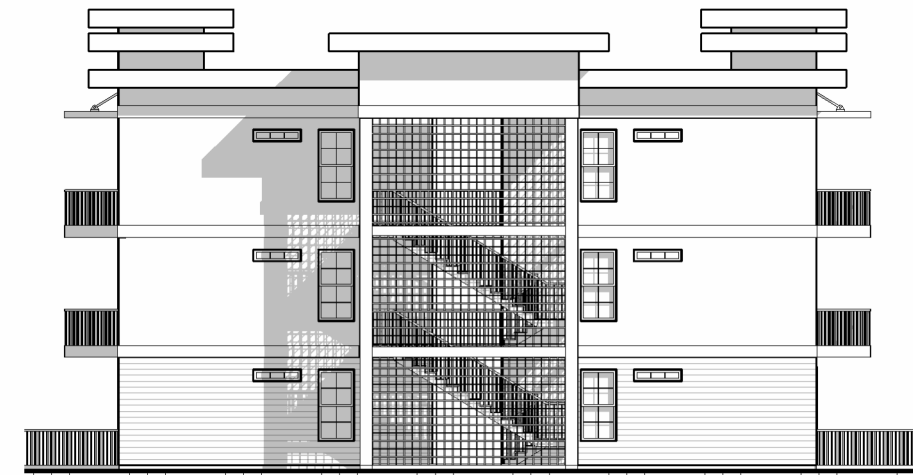

RIGHT ELEVATION



962 W 800 N, OREM, UT 84057
801.735.6314 | greg@legacyhomedesign.com
legacyhomedesign.com



3707 E. Southern Avenue
Mesa, AZ 85206
Phone: 480.734.1446

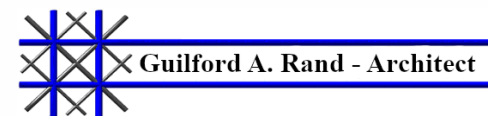

962 W 800 N, OREM, UT 84057
801.362.0343 | archcoalition@hotmail.com

BFH GROUP
COUNTRY CLUB - 36-PLEX
MESA, AZ

SQUARE FOOTAGE

UNITS		BUILDING	
ONE BEDROOM	695 SF	MAIN LEVEL	12422 SF
TWO BEDROOMS	845 SF	SECOND LEVEL	12422 SF
THREE BEDROOMS	1092 SF	THIRD LEVEL	12422 SF
		TOTAL	37265 SF

3/08/2024

A6



BACK ELEVATION

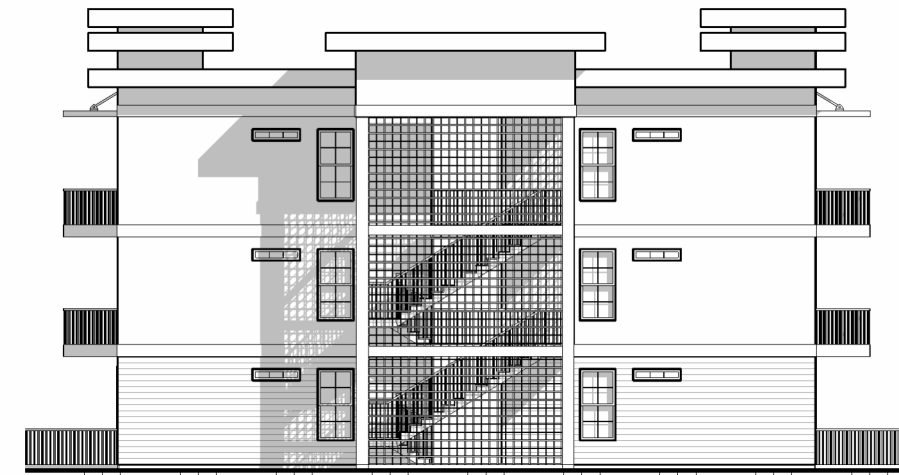

LEFT ELEVATION

SQUARE FOOTAGE

UNITS		BUILDING	
ONE BEDROOM	695 SF	MAIN LEVEL	12422 SF
TWO BEDROOMS	845 SF	SECOND LEVEL	12422 SF
THREE BEDROOMS	1092 SF	THIRD LEVEL	12422 SF
		TOTAL	37265 SF

3/08/2024

A7



962 W 800 N, OREM, UT 84057
801.735.6314 | greg@legacyhomedesign.com
legacyhomedesign.com



3707 E. Southern Avenue
Mesa, AZ 85206
Phone: 480.734.1446

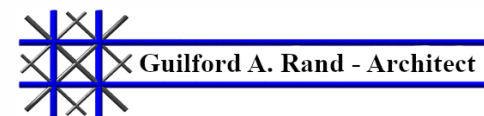

962 W 800 N, OREM, UT 84057
801.362.0343 | archcoalition@hotmail.com

BFH GROUP
COUNTRY CLUB - 36-PLEX
MESA, AZ

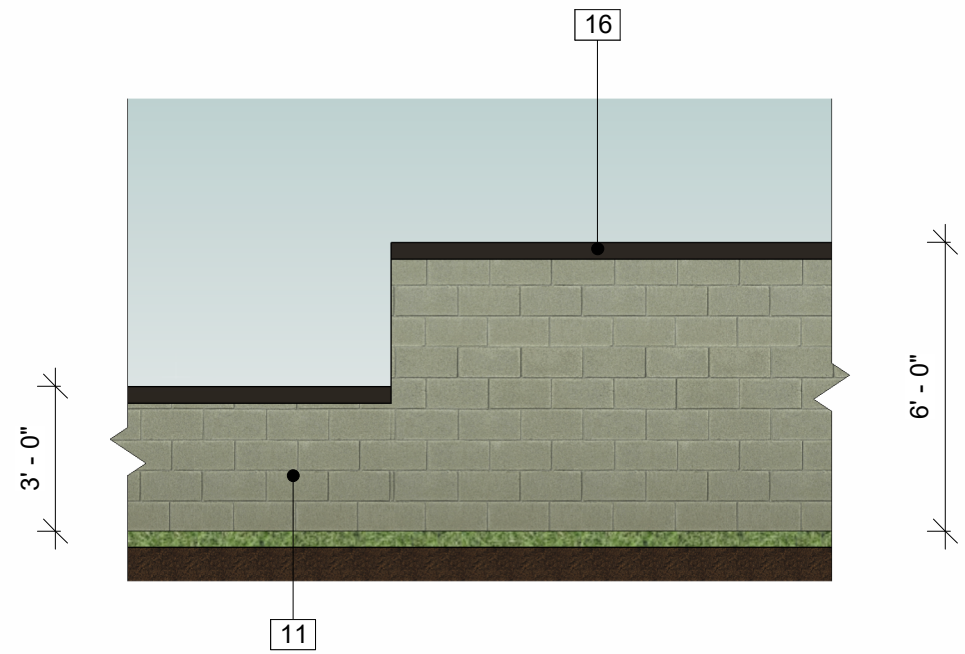

SITE WALLS

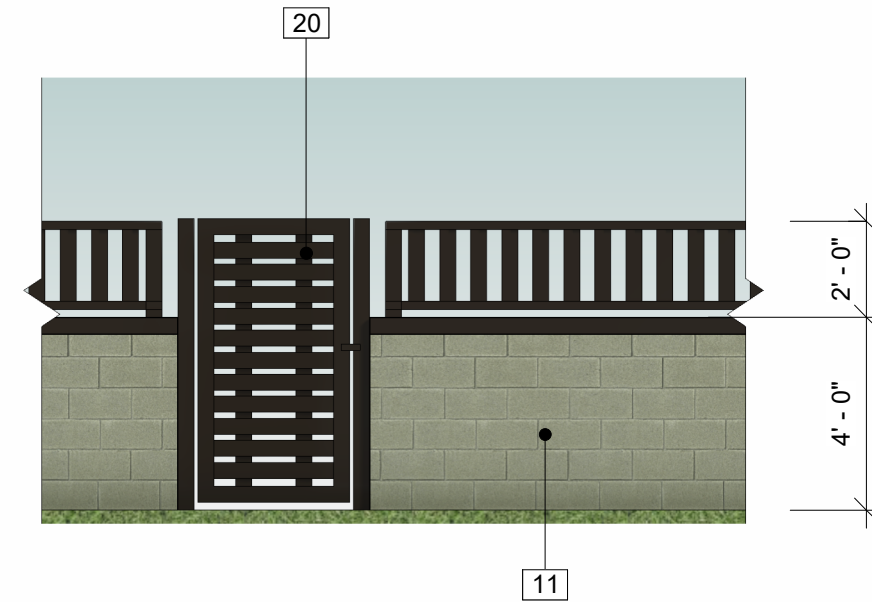

VIEW WALL

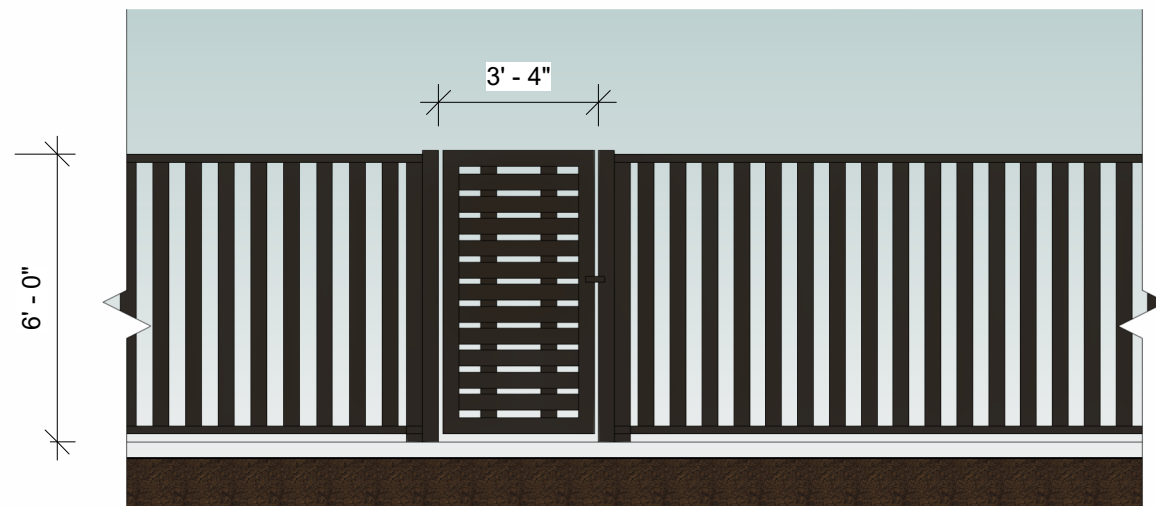

POOL FENCE

MATERIAL LEGEND	
NUMBER	MATERIAL
09	CMU WITH BRICK VENEER
11	CMU WALL - PAINTED TO MATCH SURROUNDING BUILDINGS
16	4" SOLID CMU CAP PAINTED TO MATCH DARK ANODIZED BRONZE
20	METAL - DARK ANODIZED BRONZE

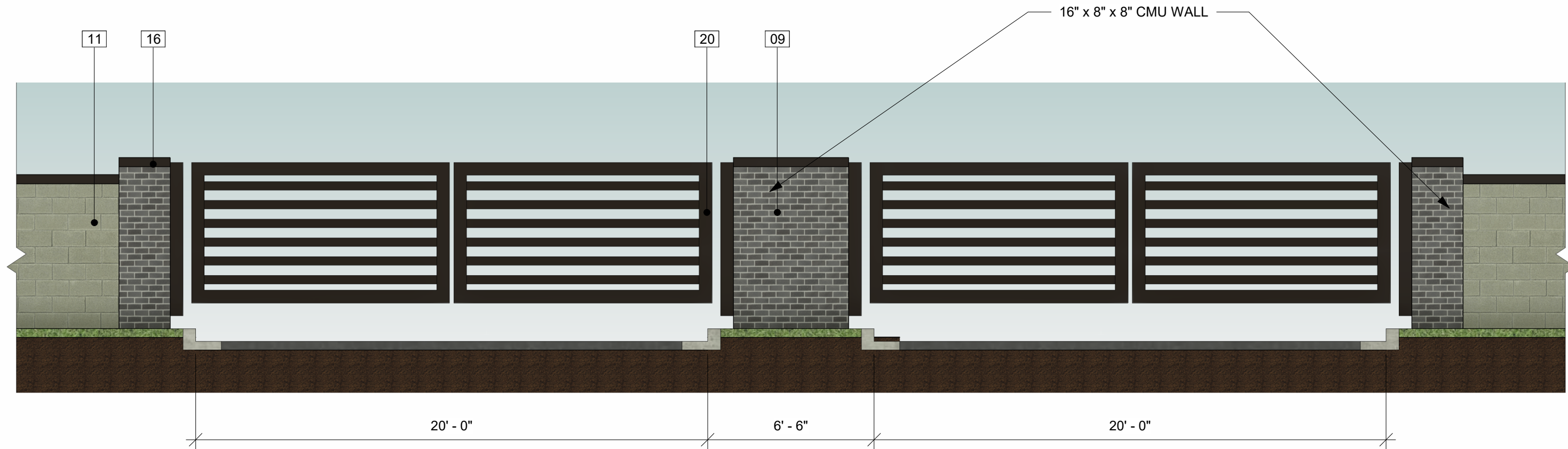

FRONT GATE

MATERIAL LEGEND	
NUMBER	MATERIAL
09	CMU WITH BRICK VENEER
11	CMU WALL - PAINTED TO MATCH SURROUNDING BUILDINGS
16	4" SOLID CMU CAP PAINTED TO MATCH DARK ANODIZED BRONZE
20	METAL - DARK ANODIZED BRONZE

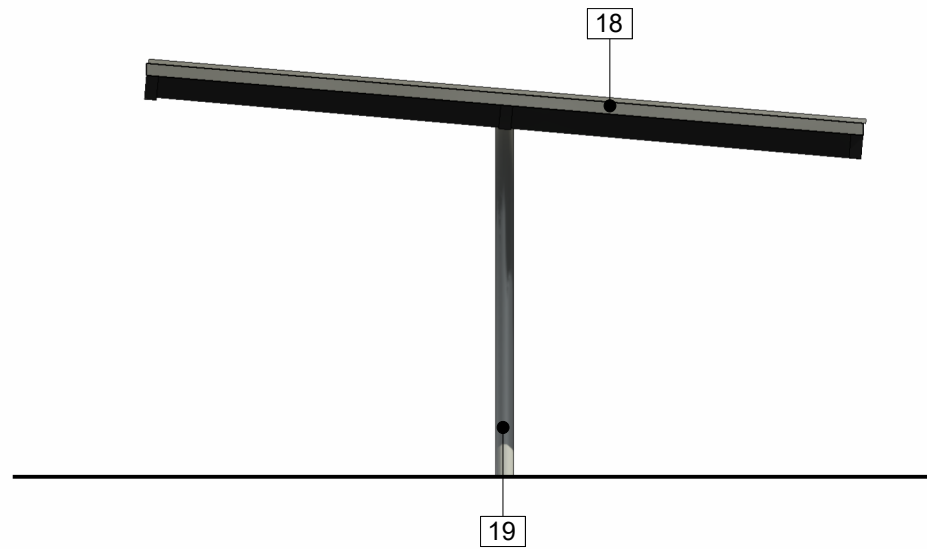

LEFT ELEVATION

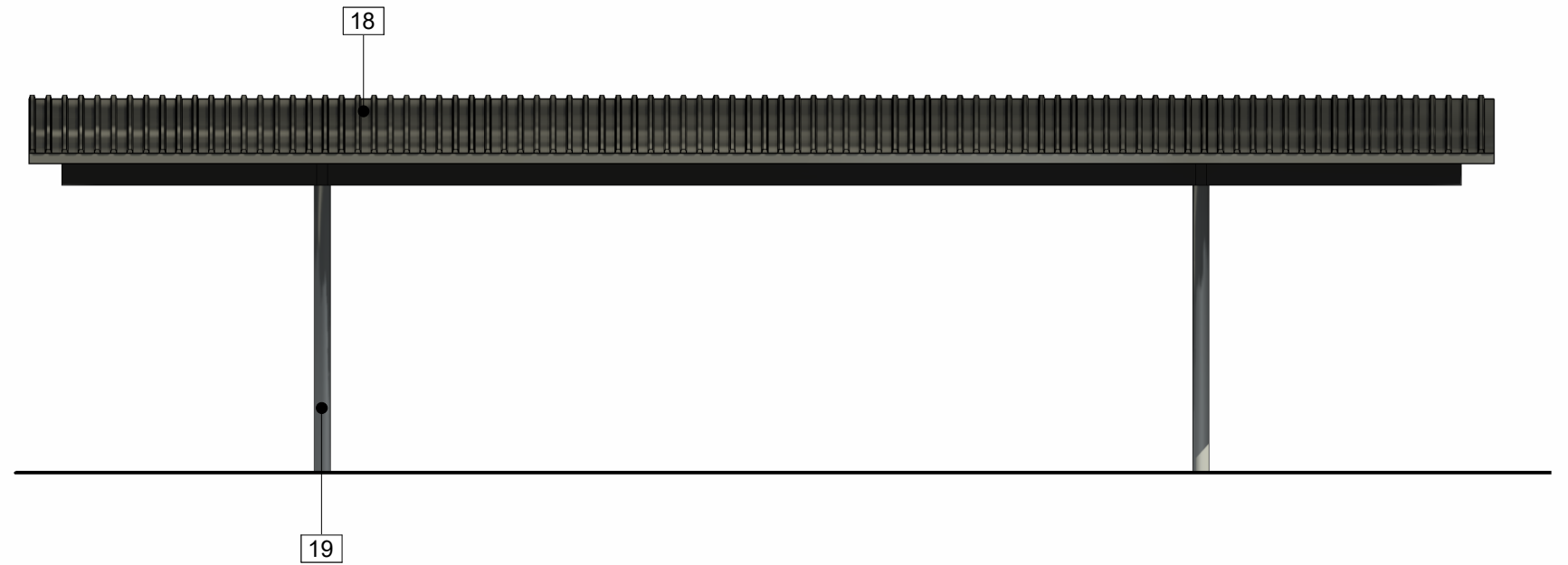

BACK ELEVATION

MATERIAL LEGEND	
NUMBER	MATERIAL
18	CORRUGATED METAL ROOF
19	METAL COLUMN

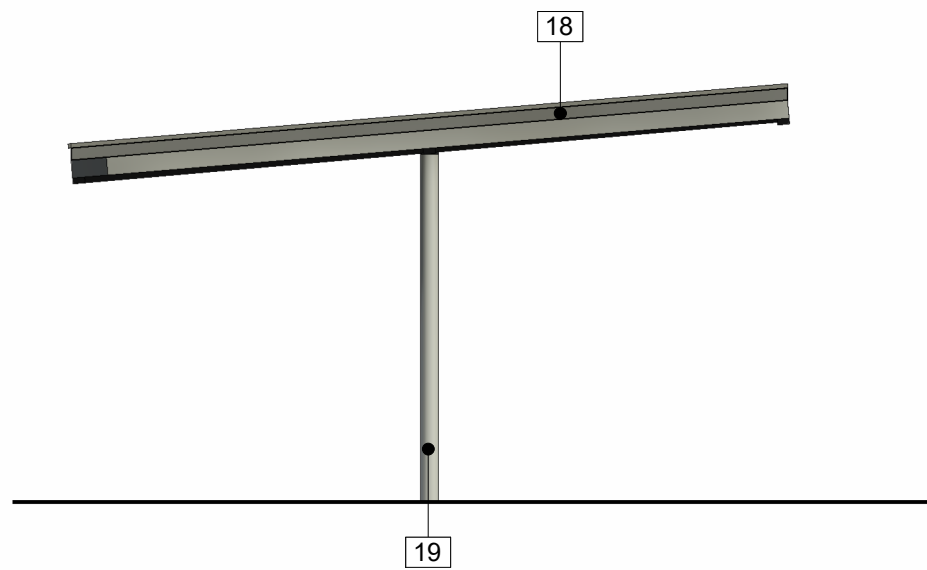

RIGHT ELEVATION

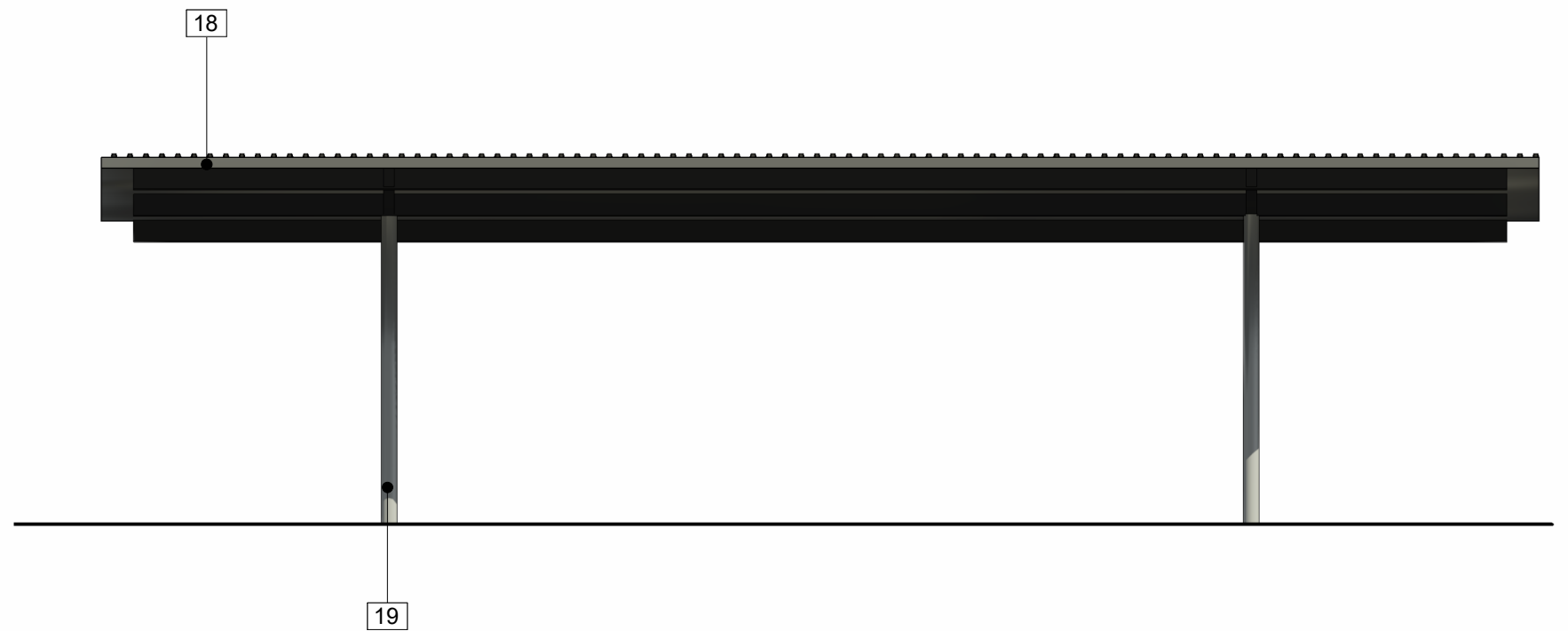

FRONT ELEVATION

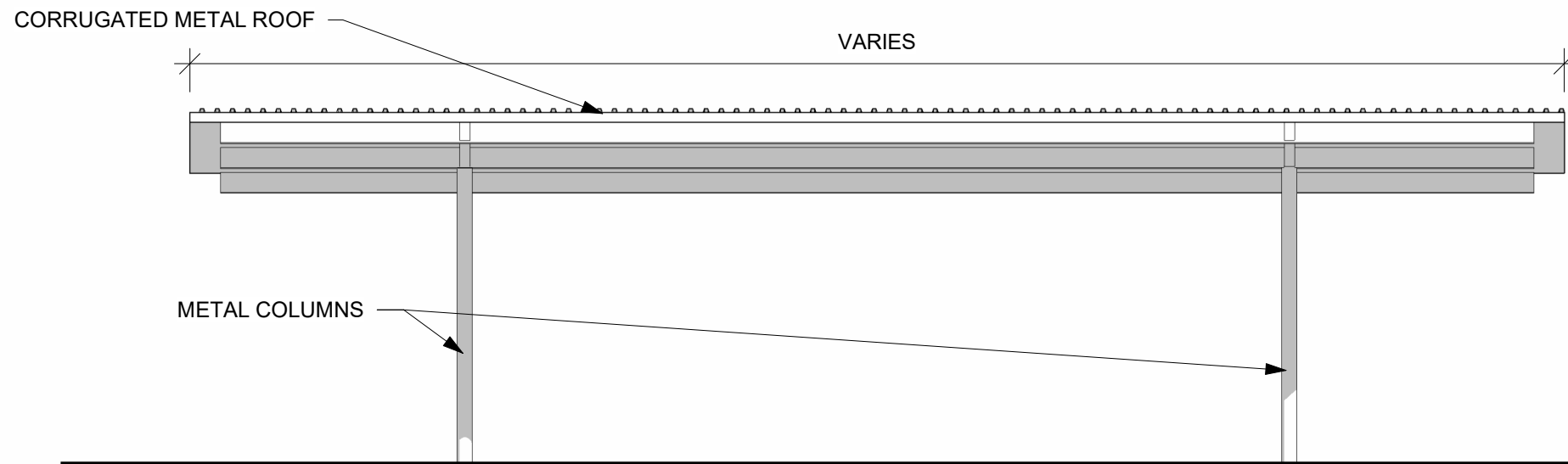

FRONT ELEVATION

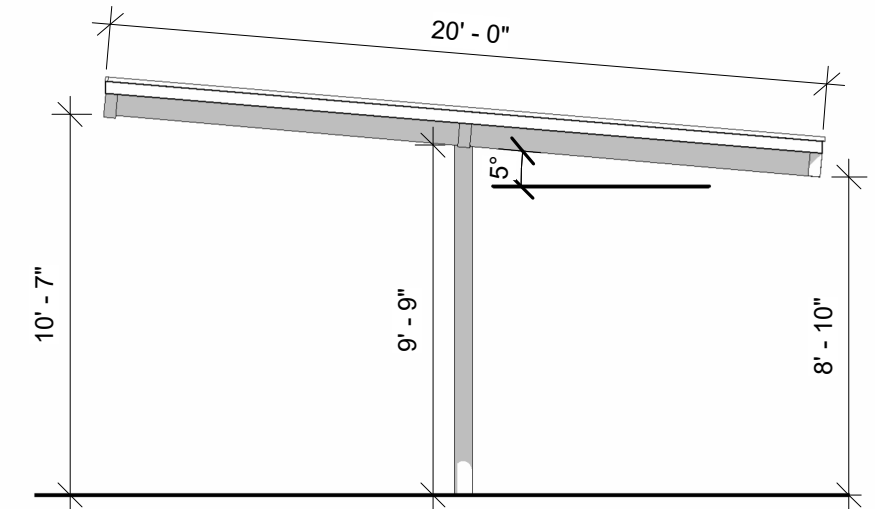

LEFT ELEVATION

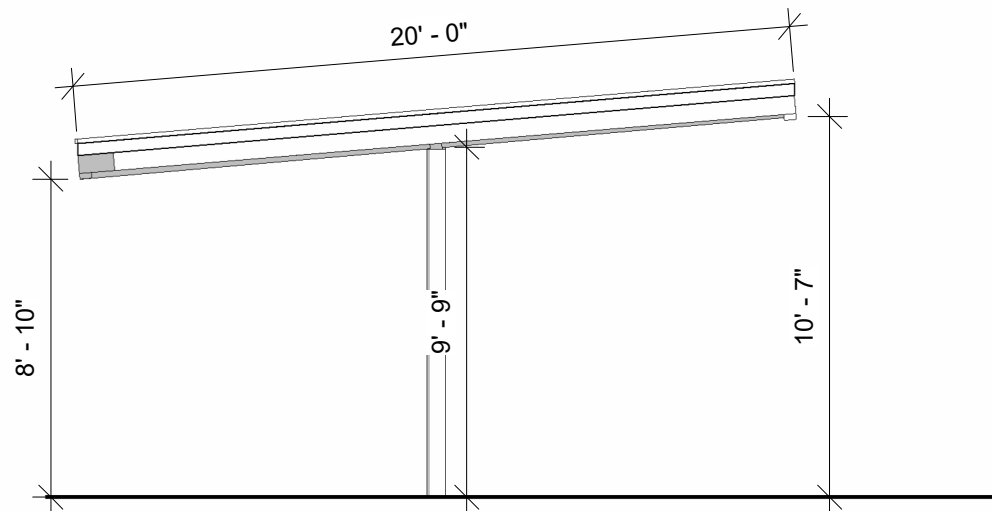

RIGHT ELEVATION

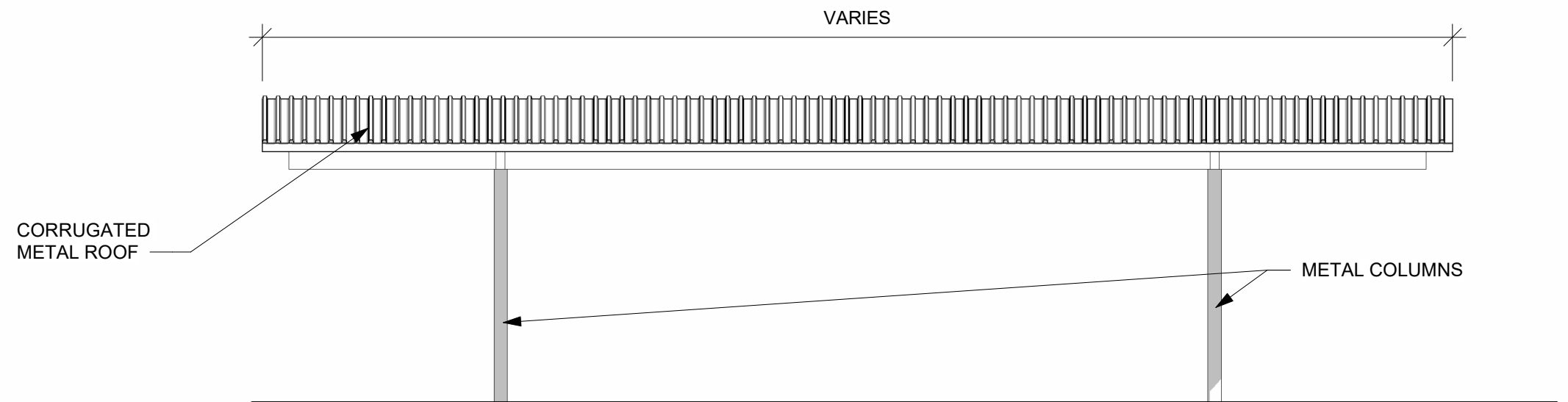

BACK ELEVATION

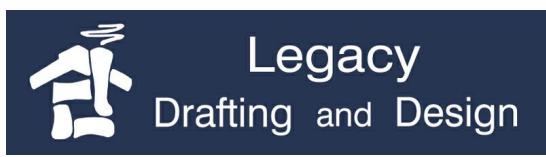

962 W 800 N, OREM, UT 84057
801.735.6314 | greg@legacyhomedesign.com
legacyhomedesign.com



3707 E. Southern Avenue
Mesa, AZ 85206
Phone: 480.734.1446

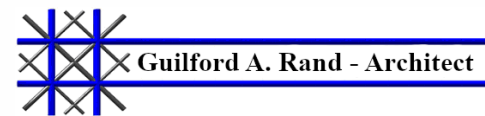

962 W 800 N, OREM, UT 84057
801.362.0343 | archcoalition@hotmail.com

COVERED PARKING
CANOPY

MESA, AZ

SQUARE FOOTAGE

1/24/2024

A2