

San Antonio Tire Shop

Rezone, Minor General Plan Amendment, BIZ Overlay, Site Plan Review

Project Narrative

Case No. ZON25-00110

1st Submittal: February 10, 2025

2nd Submittal: January 12, 2026

3rd Submittal: March 23, 2026



WITHEY
MORRIS
BAUGH

Development Team

Developer:
Tres Hermanos, LLC
Eliseo Guadarrama Ramirez
734 East Mobile Lane
Phoenix, AZ 85040

Legal Representative:
Withey Morris Baugh PLC
Adam Baugh / Alex Hayes
2525 East Arizona Biltmore Circle, Suite A-212
Phoenix, Arizona 85016

Development Consultant:
All Right Builders, Inc.
Lee Price / Tami Price
8809 West Frier Drive
Glendale, Arizona, 85305

Civil Consultant:
Saif Engineering LLC
Raad Salih, P.E.
P.O. box 10334
Tempe, Arizona 85284

Landscape Consultant:
Mac Design Studio
Steven McLeod
1525 S Higley Road, Suite 104
Gilbert, Arizona, 85296

TABLE OF CONTENTS

A. PROJECT OVERVIEW	4
B. RELATIONSHIP TO ADJACENT PROPERTIES	4
C. GENERAL PLAN AND ZONING	4
D. PROPOSED DEVELOPMENT	5
E. BIZ OVERLAY	6
F. GENERAL PLAN AMENDMENT CRITERIA	11
G. ADHERENCE WITH SITE PLAN REVIEW CRITERIA	15
H. SUMMARY.....	17

LIST OF EXHIBITS

AERIAL CONTEXT MAP	A
GENERAL PLAN MAP	B
STRATEGIC PLAN MAP	C
ZONING MAP	D
CONCEPTUAL SITE PLAN	E
PERSPECTIVE RENDERINGS	F
LANDSCAPE PLAN.....	G

A. Introduction and Project Overview

On behalf of Eliseo Guadarrama Ramirez (the Applicant), this application is a request for approval of a rezone, minor General Plan amendment, Bonus Intensity Zone (BIZ) overlay, and Site Plan Review for the approximately 0.39 net acre property located at the southwest corner of University Drive and Longmore, otherwise commonly known as Maricopa County Assessor’s Parcel Number 135-64-116 (the Property) (See **Tab A, Aerial Map**). The Property is currently operated as the San Antonio Tire Shop and was previously utilized for a gas station.

The Property is an undersized parcel that presents numerous development challenges. As detailed herein, the intent of the BIZ Overlay is to establish site-specific development standards and design criteria for development and operation of the Property for a high-quality minor auto repair business. The proposed development will substantially improve the existing condition of the site and support small business growth within the City of Mesa.

B. Relationship to Adjacent Properties

The Property is bounded by right of way on the north and east. To the north is University Drive, across which is a strip retail center zoned LC. To the east is Longmore, across which is an existing auto repair business zoned LC. To the south and west are single-family residential uses zoned RS-6.

Direction	Existing Land Use	Existing Zoning
North	Mixed Use - Restaurants & Retail Stores	LC
East	Pineda Tire Shop/Auto Repair	LC
South	Residential separated by alley	RS-6
West	Residential	RS-6

C. General Plan and Zoning

The City of Mesa 2050 General Plan, which was adopted in November 2024, includes substantial changes to the City’s land use categories and corresponding planning requirements and guidelines. The updated General Plan Land Use Map designates the Property as Urban Residential with an Evolve Growth Strategy. (See **Tab B, General Plan Map**). The Urban Residential placetype

contemplates a diverse mixture of uses where commercial, residential, and public/semi-public uses co-exist. However, the General Plan classifies the proposed minor auto repair use as “Convenience Services”, which is not identified as a principal or supporting use in the Urban Residential placetype. Accordingly, this application requests a minor General Plan amendment to change the Property’s placetype to Urban Center with an Evolve growth strategy. This change is consistent with the General Plan amendment criteria as detailed in Section F below.

The Property is also located within the West Main Street Area Plan, the intent of which is to provide for transit-oriented development that contains mixed use. (See **Tab C, Area Plan Map**). However, the Property is located on the northern perimeter of the Area Plan within the Neighborhood Opportunity Area and is not located within the TOD Station Area or the TOD Corridor Area. The Property is already zoned for commercial uses and the proposed rezone will allow for redevelopment of a dilapidated infill site, which is consistent with the goals of the Area Plan.

The existing zoning for the Property is Office Commercial (OC). (See **Tab D, Zoning Map**). This district is intended for small scale medical and professional offices. Given the small size of the parcel and the parking requirements associated with such uses, the OC district is not practical for the Property. Accordingly, this application requests to rezone the Property to Limited Commercial (LC) to accommodate the proposed use.

D. Proposed Development

The Applicant proposes development of the Property with a minor auto repair shop. The footprint of the building, which is existing and will be repurposed and refurbished, encompasses approximately 4,015 square feet. (See **Tab E, Conceptual Site Plan**). The building is located in the rear half of the property with an existing canopy (dating from the Property’s use as a gas station) that extends northward towards University Drive. The building features a smooth stucco surface and a refurbished rectilinear massing that reinforces a professional commercial appearance. The front (north) elevation incorporates upgraded glazing at the customer entrance and clearly defined pedestrian access points, giving the building a more aesthetic street presence. (See **Tab F, Conceptual Renderings**).

The site design introduces organized parking areas, including striped customer stalls, accessible parking, and a more efficient circulation pattern for vehicle entry and exit. New landscaping, including shrubs, trees, decorative gravel areas, and landscape islands, softens the edges of the site and enhances the curb appeal while better accommodating the City’s modern landscaping standards. Updated screening elements, including low CMU walls and strategic plant placement, help buffer operational areas without obstructing visibility or compromising site functionality. (See **Tab G, Landscape Plan**).

Primary access to the site is via an entry-only driveway from University Drive. Vehicles exit the site to Longmore via an exit-only driveway in the southeast corner of the Property. A total of seven (7) parking spaces are provided with one (1) space designed for ADA compliance. A total of eleven (11) parking spaces are required per Mesa Zoning Ordinance (MZO) ratios. Accordingly, a parking reduction is requested as detailed below in Section E.

E. BIZ Overlay

The proposed development shall comply with the applicable MZO development standards for the LC district, except as modified below. The Project also meets the criteria for the requested BIZ Overlay by providing Superior Design per Section 11-31-32 of the MZO and addressing environmental performance standards as detailed below. Though limited substantially by the Property's small size and two street frontages, the proposed development takes a responsive approach to the site and site context to significantly improve the aesthetic and functional qualities of the Property.

Superior Design

a. High-quality materials, building form, and cohesive site design

The project incorporates high-quality, context appropriate materials and architectural detailing that create a cohesive and visually distinctive development. The existing building will be fully refurbished with smooth stucco finishes, upgraded glazing, and refreshed architectural detailing that reinforce a clean and professional commercial appearance.

The design integrates public art with a desert landscape mural along the Longmore frontage, which adds visual interest, reinforces local character, and creates a recognizable identity for the corner. The mural, combined with enhanced landscaping, decorative screening walls, and updated architectural finishes, creates a significantly enhanced site design.

b. Compatibility with character of surrounding area and creation of a sense of place

The project reflects the existing development pattern along this section of University Drive, which consists primarily of small-scale commercial and some automotive service uses serving adjacent neighborhoods. The proposed improvements elevate the architectural and landscape quality of the site while maintaining compatibility with adjacent development.

The redevelopment also incorporates design features that contribute to a unique sense of place, including the custom mural, enhanced street landscaping, and improved pedestrian interface along both street frontages.

c. Site design, architecture, and landscaping features that address local climate

The site design incorporates several features that respond to the desert climate and promote pedestrian comfort and sustainability. The existing canopy structure, which will be retained and refurbished, provides shade coverage that reduces summer sun exposure for vehicles and pedestrians within the site. A shaded customer waiting area with seating is also provided at the building entrance to create a comfortable space for customers.

The landscape design emphasizes low-water-use desert-adapted plant materials, including native trees, shrubs, and drought-tolerant ground cover that minimize irrigation demand while enhancing the visual quality of the site. The redevelopment also repurposes the existing building rather than demolishing it, reducing construction waste and supporting the City's goals for adaptive reuse and sustainable infill development.

d. Design features exceeding minimum ordinance standards

Although several development standards are modified through the BIZ overlay due to the unique constraints of the property, the project nonetheless exceeds the qualitative design objectives of the Mesa Zoning Ordinance through significant site and architectural upgrades. The redevelopment introduces:

- Substantial new landscaping and streetscape improvements along both street frontages
- Decorative screening walls and landscape buffering to soften operational areas
- Public art and architectural enhancements not required by code
- Improved site organization and circulation compared to the existing condition

Collectively, these elements produce a significantly higher-quality built environment than currently exists on the property and demonstrate the enhanced design approach contemplated by the BIZ overlay.

e. Attractive and comfortable pedestrian environment

The redevelopment significantly improves the pedestrian experience along the street frontages and within the site by introducing new landscaping, shade elements, pedestrian seating, and a visually engaging streetscape anchored by the Longmore mural.

Low masonry screening walls combined with landscaping help define the street edge while maintaining visibility and safety. The pedestrian pathway connecting the building entrance to the public sidewalk provides clear and convenient access for customers arriving on foot.

These improvements create a more attractive and comfortable environment for pedestrians, replacing the current underutilized and visually degraded site with a welcoming commercial corner.

Environmental Performance Standards

The project incorporates several design elements that reduce environmental impacts while supporting sustainable site development consistent with Section 11-21-3(B)(2) of the MZO.

a. Site Selection – Redevelopment of Economically Distressed Property

The project represents the redevelopment and rehabilitation of an aging commercial property, originally developed as a gas station. The proposed investment revitalizes a long-standing commercial corner that has experienced physical deterioration and underinvestment. Through building refurbishment, site improvements, landscaping upgrades, and architectural enhancements, the project transforms a commercial property into a productive and attractive neighborhood-serving business, consistent with the ordinance’s encouragement of redevelopment and reinvestment in existing developed areas.

b. Bicycle storage

The site design provides safe and convenient bicycle parking located near the building entrance, allowing customers and employees arriving by bicycle to securely store bicycles within a short and direct walking distance of the building entrance.

c. Restoration with native or adapted vegetation

The Property is a previously developed commercial site, formerly used as a gas station and later as a commercial service use. The proposed redevelopment includes substantial new landscaping with native and desert-adapted vegetation, including trees, shrubs, and ground cover materials appropriate to the environment. These improvements replace existing underutilized and minimally landscaped areas with enhanced planting areas that soften the visual character of the site and create a more attractive environment for customers and pedestrians.

BIZ OVERLAY TABLE		
LC Development Standards	Proposed Standard	Justification
<u>Parking Area Design</u> – <i>MZO Section 11-32-4(A)</i> -Minimum 50’ setback for parking spaces along main drive aisles connecting directly to a street and drive aisles that cross such main drive aisles	12’-10”	The small scale of this site makes compliance with this standard practically infeasible. The Property is only 133’ by 125’ and providing a 50’ setback would severely limit the developable area. The proposed standard allows for productive use of the Property with an efficient parking and circulation plan.
<u>Parking Reduction</u> – <i>MZO Section 11-32-3</i> - General Auto Repair (1/375 sf) 11 parking spaces required	4 parking spaces provided (includes 1 ADA space)	See additional discussion below.

<p><u>Parking Lot Landscape Islands</u> <i>MZO Section 11-33-4(B)</i> - Parking lot landscape islands required at each end of a row of stalls. Minimum dimensions: 8' wide and 15' long</p>	<p>4 landscape islands provided in varying sizes</p>	<p>Though parking lot landscaping is provided with trees and shrubs, it is impossible to achieve the full landscape island dimensions per the MZO without severely limiting site circulation and functionality.</p>
<p><u>Building/Parking Area Setback</u> – <i>MZO Section 11-6-3.A</i> - Minimum 15' (Front- North) - Minimum 25' (Side adjacent RS - West) - Minimum 25' (Rear adjacent RS - South) - Minimum 15' (Street facing side - east)</p>	<p>North: 15' to parking lot West: 5'-1" to parking lot 23'-2" to building South: 22'-3" to building East: 10'-8" to building 14'-6" to parking lot</p>	<p>Because the existing building will remain and be repurposed, achieving the full setbacks required by the MZO is not feasible on this small infill site. The proposed setbacks accommodate the practical limitations of the site and enable adequate parking and circulation. Nevertheless, the proposed redevelopment will drastically improve the existing site conditions and create a more attractive streetscape while maintaining adequate buffers from adjacent uses.</p>
<p><u>Landscape Setback Adjacent RS or RSL district</u> – <i>MZO Section 11-33-3(B)(1)</i> - Minimum 20' required</p>	<p>Varies - 5'-0" to 5'-8"</p>	<p></p>
<p><u>Foundation Base</u> – <i>MZO Section 11-33-5(A)(1)</i> - Required 15 feet along exterior wall with public entrance</p>	<p>0'</p>	<p>Given the nature of the proposed use, the location of the existing building, and the location of the drive aisles and pedestrian connections, the minimum foundation base required by code is not achievable on all elevations.</p>
<p><u>Foundation Base</u> – <i>MZO Section 11-33-5(A)(2)</i> - Required 5 feet along exterior wall with no public entrance</p>	<p>West: 4'-10" East: 11'2" South: 2'-10"</p>	<p>A shaded customer waiting area with seating is provided at the building entrance and landscaping provided in the parking area and along the street frontages will provide an aesthetic customer experience. Notably, the provided percentage of landscape material exceeds the minimum required in the foundation bases provided on the south, east, and west elevations. The east elevation also</p>
<p><u>Plant Material in Foundation Base</u> – <i>MZO Section 11-33-5(B)(3)(a)</i> <i>Landscape area equal in length to 33% of adjacent exterior wall visible from right of way or public parking area</i></p>	<p>No landscape area provided in foundation base visible from right of way or public parking area along north elevation</p>	<p></p>

		provides an enhanced foundation base.
<u>Minimum Lot Size – Minor Automobile/Vehicle Service and Repair</u> <i>MZO Section 11-31-6</i> - Minimum 1 acre required	0.39 acres	The project’s scale, design, and operational characteristics are compatible with surrounding commercial uses and will not create any functional or aesthetic impacts that a larger site would otherwise mitigate. Granting this relief allows productive reuse of an existing small lot while advancing the City’s goals for reinvestment, small-business support, and revitalization of older commercial corridors.
<u>Bay Door Screening -</u> <i>MZO Section 11-30-9(F)(2)</i> - When bay doors are less than 200’ from an adjacent street and less than perpendicular to street, 6’ screen wall required	3’ 4” screen wall provided along University Drive	Because the project is repurposing the existing building and University Drive driveway, a 6’ screen wall along the frontage is not practical without impacting site visibility, access, and circulation. The provided screen wall and landscaping will improve the current condition and ensure sufficient site aesthetics
<u>Screen Wall Setback –</u> <i>MZO Section 11-30-(H)(7)</i> - Minimum 10’ setback required between screen wall and right of way	0’	The Property’s small size and two street frontages make conformance with this standard impractical. The provided landscaping and low screen wall ensure adequate separation and drastically improves the current condition.
<u>One-Way Drive Aisle Width –</u> <i>MZO Section 11-32-2(J)</i> - one way drive aisles that do not provide access to parking spaces must be at least 12-feet wide	11’-9”	The proposed minor deviation allows for improved site circulation while enabling adaptive reuse of the existing building.

<p><u>Pedestrian Connection –</u> <i>MZO Section 11-30-8(A)</i> - On-site walkway required from primary entry to public sidewalk on each street frontage</p>	<p>5' wide pedestrian walkway provided from public entrance to public sidewalk on Longmore</p>	<p>With only approximately 260' of street frontage, the 5' wide walkway from Longmore provides adequate pedestrian access without further limiting site functionality.</p>
--	--	--

Parking Reduction

The proposed use requires a limited number of employees on-site at any given time. Typical staffing levels include two to three technicians and one service manager or owner. Customer visitation is short in duration, staggered throughout the day, and generally limited to drop-offs and pick-ups rather than extended stays. Most customers leave their vehicles on-site temporarily for service rather than remaining parked for extended periods. Because the nature of the use does not generate high customer turnover or prolonged customer parking demand, the practical parking needs of the business are substantially lower than the typical ratios applied to higher-intensity commercial uses. The four (4) provided spaces (including one ADA space) sufficiently accommodate both employees and customer turnover.

The Property is also constrained, with only 0.39 net acres and two street frontages. These conditions severely limit where parking can be located while still maintaining safe site circulation, required landscape buffers, access spacing requirements, and separation between pedestrian and vehicle movements. Achieving the full required number of parking spaces would necessitate redesigning the site in a way that would compromise circulation, eliminate required landscaping, or create unsafe vehicular access patterns. The BIZ overlay is explicitly intended to resolve such site-specific constraints by allowing flexibility while still achieving safe and functional design outcomes.

F. General Plan Amendment Criteria

1. Whether the proposed amendment will result in a shortage of land or other planned uses, such as, whether the change will result in a substantial and undesirable reduction in the amount of available land for employment.

The Property is already zoned for non-residential uses and the proposed General Plan amendment and rezone will not change that. The existing Urban Residential placetype contemplates a diverse mixture of uses where commercial, residential, and public/semi-public uses co-exist. The amendment will simply allow for a broader range of neighborhood commercial services available under the Urban Center placetype, including Convenience Services. The Urban Center placetype is prominent in the broader vicinity of the Property, most notably along Main Street.

2. Whether events after the adoption of the General Plan have changed the character or condition of the area, making the proposed amendment appropriate.

The proposed use is compatible with the character of the area, as evidenced by similar existing uses in the immediate vicinity. The proposed LC zoning district and specific use were compatible with the Property's General Plan character type in the 2040 General Plan, which was the General Plan of record when this entitlement process began. The proposed amendment will simply continue to permit the compatible uses.

3. The degree to which the proposed amendment will impact the whole community or a portion of the community by:
 - a. Altering acceptable existing land use patterns in a significant way that is contrary to the Vision, Guiding Principles, or Strategies identified in the General Plan.

The proposed amendment will not significantly alter the land use patterns in the area. The Property is already designated for non-residential uses. However, the small size of the parcel makes it incompatible with the uses contemplated by its existing zoning. The proposed amendment will simply allow a broader range of neighborhood commercial uses, including "Convenience Services". These uses are appropriate along a major arterial road such as University Drive.

- b. Requiring larger or more extensive improvements to roads, sewer, or water systems than are necessary to support the prevailing land uses which may negatively impact development of other lands.

The Property is less than one half of an acre and the scope of the proposed development and corresponding general plan amendment will not require any improvements to existing infrastructure.

- c. Adversely impacting existing uses due to increased traffic congestion that is not accommodated by planned roadway improvements or other planned transportation improvements such as nonmotorized transportation alternatives and transit.

As described above, the small scale of the Property and the proposed use will not cause any meaningful increases in traffic or adversely impact any existing uses.

4. Whether the proposed amendment is consistent with the Vision, Guiding Principles, or Strategies of the General Plan.

The proposed amendment is consistent with the following Guiding Principles and Strategies in the General Plan:

Guiding Principle: Our Economy is Innovative and Prosperous

Strategy ED2: Sustain a business climate that fosters entrepreneurs and small businesses.

The proposed General Plan amendment directly supports Strategy ED2 by facilitating the operation and long-term viability of a locally owned small business. The San Antonio Tire Shop is owned and operated by a local business owner and provides neighborhood-serving automotive services and local employment within an established commercial corridor. Allowing the Property to transition from the Urban Residential to the Urban Center placetype ensures that this small, service-oriented business, operating on a uniquely constrained parcel, can remain competitive and continue contributing to Mesa’s economic diversity.

The requested rezone and BIZ overlay enable reinvestment and revitalization of this commercial corner. Supporting the reinvestment of capital into site upgrades, façade improvements, and landscaping, the City is affirming its commitment to creating an environment where small businesses can modernize, operate safely, and thrive. This approach is fully consistent with the General Plan’s emphasis on cultivating homegrown businesses and removing barriers to entrepreneurial success.

Guiding Principle: Our Neighborhoods are Vibrant, Diverse, and Safe Places Where Our People Thrive.

Strategy N2: Promote adaptive reuse and infill as tools to rejuvenate and revitalize established neighborhoods.

The Property is a small parcel with unique challenges that limit its development potential. It was previously developed as a gas station and later housed a commercial carpet wholesaling business. Rather than leaving the aging structure underutilized or pursuing demolition for speculative redevelopment, the Applicant proposes to repurpose, refurbish, and significantly upgrade the existing building and surrounding site development.

The project improves the appearance, function, and compatibility of the site through enhanced landscaping, new screening, improved circulation, pedestrian-oriented features, and professional façade treatments, including a new mural on the Longmore frontage. These investments revitalize a long-standing commercial corner and eliminate blighted conditions while maintaining a scale appropriate to the surrounding residential and commercial context. The proposed redevelopment will provide a more attractive streetscape along University Drive.

Guiding Principle: Our City Offers Integrated and Balanced Land Uses with a Variety of Neighborhoods and Business Opportunities

Strategy LU2: Encourage infill and redevelopment to meet the community’s strategic needs.

The Property is less than half an acre and constrained by two street frontages. Thus, it is not well suited for the types of residential or office uses contemplated under the Urban Residential placetype. Redevelopment of such a site requires flexible zoning tools to unlock its economic potential and accommodate physical constraints.

The project provides a strategic infill solution by modernizing an existing commercial building, improving site conditions, and delivering a conveniently located, neighborhood-serving business along a major arterial. It also prevents the parcel from becoming underutilized or falling into disrepair, which is an outcome the General Plan seeks to avoid through proactive infill and reinvestment policies.

By enabling a meaningful upgrade to an existing commercial corner without requiring additional infrastructure or expansion into adjacent residential areas, the amendment supports a more efficient land-use pattern and reinforces the City's commitment to sustainable redevelopment.

5. Whether the proposed amendment constitutes an overall improvement to the General Plan and the City of Mesa.

The proposed amendment constitutes an overall improvement to the General Plan by aligning the Property's placetype designation with its physical characteristics, historic use, and surrounding land-use context. The existing Urban Residential designation does not reflect the long-established commercial pattern along University Drive nor the constrained size and configuration of the parcel, which make it unsuitable for residential or office-centered intensities. Shifting the placetype to Urban Center more accurately captures the Property's existing role as a neighborhood-serving commercial site and permits a realistic range of uses that can operate successfully on such a uniquely constrained parcel.

6. The extent to which the benefits of the proposed amendment outweigh any of the impacts identified by these criteria.

The benefits of the proposed amendment substantially outweigh any potential impacts. The project enables meaningful reinvestment in an aging commercial property, supports a locally owned business, improves streetscape aesthetics, upgrades landscaping and screening, and preserves an appropriate buffer between commercial activity and adjacent single-family homes. The proposed use is small in scale, generates minimal traffic, and is compatible with both the existing zoning pattern and surrounding land uses, including other commercial and auto-service businesses along University Drive.

No public infrastructure improvements are required, and the project does not adversely impact traffic flow, utility capacity, or neighborhood character.

G. Adherence with Site Plan Review Criteria

The Project has been designed to adhere to the Site Plan Review (SPR) criteria specifically noted in Ordinance Section 11-69-5.A as follows:

- A. The project is consistent with and conforms to the adopted General Plan and any applicable sub-area or neighborhood area plans (except no analysis of the use if it is permitted in the zoning district on the property), is consistent with the development standards of this Ordinance, and is consistent with and meets the intent of any applicable design guidelines.

Response: The proposed development is consistent with the requested Urban Center place type and the Main Street Area Plan. The project provides a strategic infill solution by modernizing an existing commercial building, improving site conditions, and delivering a conveniently located, neighborhood-serving business along a major arterial.

- B. The project is consistent with all conditions of approval imposed on the property whether by ordinance, resolution or otherwise.

Response: The Project will comply with all conditions of approval associated with the requested rezone and BIZ Overlay.

- C. The overall design of the project, including but not limited to the site layout, architecture of the buildings or structures, scale, massing, exterior design, landscaping, lighting, and signage, will enhance the appearance and features of the site and surrounding natural and built environment.

Response: The project enables meaningful reinvestment in an aging commercial property, supports a locally owned business, improves streetscape aesthetics, upgrades landscaping and screening, and preserves an appropriate buffer between commercial activity and adjacent single-family homes.

- D. The site plan is appropriate to the function of the project and will provide a suitable environment for occupants, visitors, and the general community.

Response: The site plan vastly improves the existing appearance and functionality of the Property. The site design is appropriate for the proposed use and will provide a quality environment for customers and employees.

- E. Project details, colors, materials, and landscaping are internally consistent, fully integrated with one another, and used in a manner that is visually consistent with the proposed architectural design.

Response: The Project provides details, colors, materials, and landscaping that are internally consistent and integrated in a manner visually consistent with the architectural design, creating a cohesive aesthetic throughout.

- F. The project is compatible with neighboring development by avoiding big differences in building scale and character between developments on adjoining lots in the same zoning district and providing a harmonious transition in scale and character between different districts.

Response: The project maintains appropriate scale at this commercial corner in a manner compatible with the existing commercial development along University Drive. It also maintains a scale appropriate to the surrounding residential to the south and east.

- G. The project contributes to the creation of a visually interesting built environment that includes a variety of building styles and designs with well-articulated structures that present well designed building facades, rooflines, and building heights within a unifying context that encourages increased pedestrian activity and promotes compatibility among neighboring land uses within the same or different districts.

Response: The project improves the appearance, function, and compatibility of the site through improved landscaping, new screening, improved circulation, pedestrian-oriented features, and professional façade treatments, including a new mural on the Longmore frontage. These investments revitalize a long-standing commercial corner and eliminate blighted conditions while maintaining a scale appropriate to the surrounding residential and commercial context. The proposed redevelopment will provide a more attractive streetscape along University Drive.

- H. The streetscapes, including street trees, lighting, and pedestrian furniture, are consistent with the character of activity centers, commercial districts, and nearby residential neighborhoods.

Response: Street trees, lighting, and pedestrian amenities will be incorporated as part of the project's frontage improvements to create a cohesive and attractive streetscape. These elements will complement existing features along University Drive and enhance the pedestrian experience for nearby residents and businesses. Together, these enhancements ensure the project's streetscape is consistent with the visual and functional quality of the development.

- I. Street frontages are attractive and interesting for pedestrians and provide for greater safety by allowing for surveillance of the street by people inside buildings and elsewhere.

Response: The proposed redevelopment will provide a more attractive streetscape along both University Drive and Longmore. Improved landscaping and site design, including the

installation of a new mural along Longmore, will create more interesting pedestrian experience.

- J. The proposed landscaping plan is suitable for the type of project and site conditions and will improve the appearance of the community by enhancing the building and site design; and the landscape plan incorporates plant materials that are drought-tolerant, will minimize water usage, and are compatible with Mesa's climate.

Response: The landscape design features native desert plants and appropriate trees, shrubs, and ground cover materials to accentuate the natural environment. The plants require minimal irrigation beyond establishment, and as native varieties should thrive with naturally occurring rainfall. Parking areas are screened with patterned masonry walls and landscape trees and shrubs.

H. Summary

This proposed rezone and BIZ Overlay represents an opportunity for reinvestment in a challenging property, transforming a dilapidated and underutilized site into a productive small-business operation. By activating the parcel with a locally owned service use, the project supports Mesa's small-business economy and adds skilled employment opportunities to the area. The redevelopment will revitalize the Property with a clean, functional design that enhances curb appeal and the character of this corridor.

TAB A

Aerial Map



SWC University Dr and Longmore, Mesa



TAB B

General Plan Map

Existing General Plan: Urban Residential

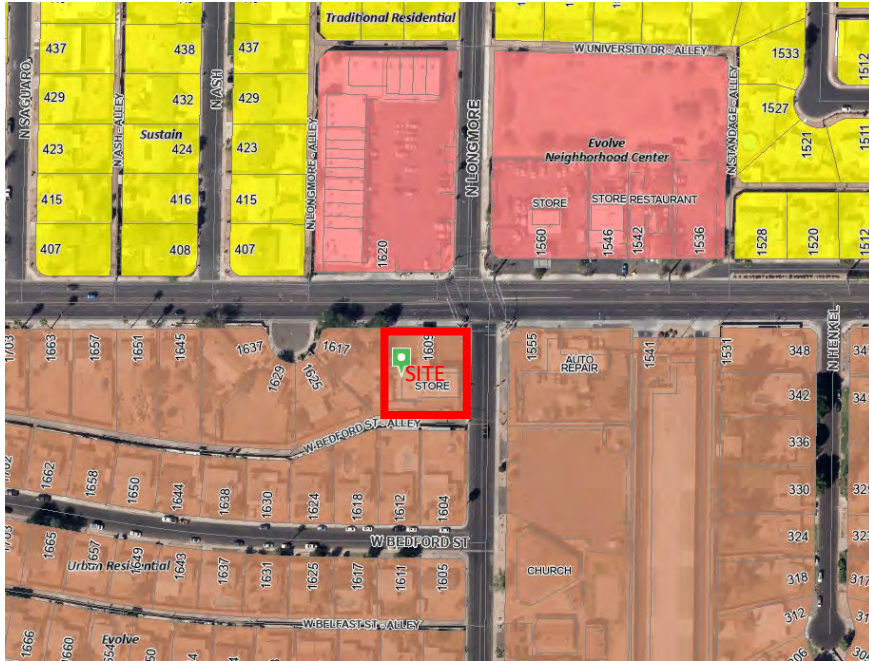

Proposed General Plan: Urban Center

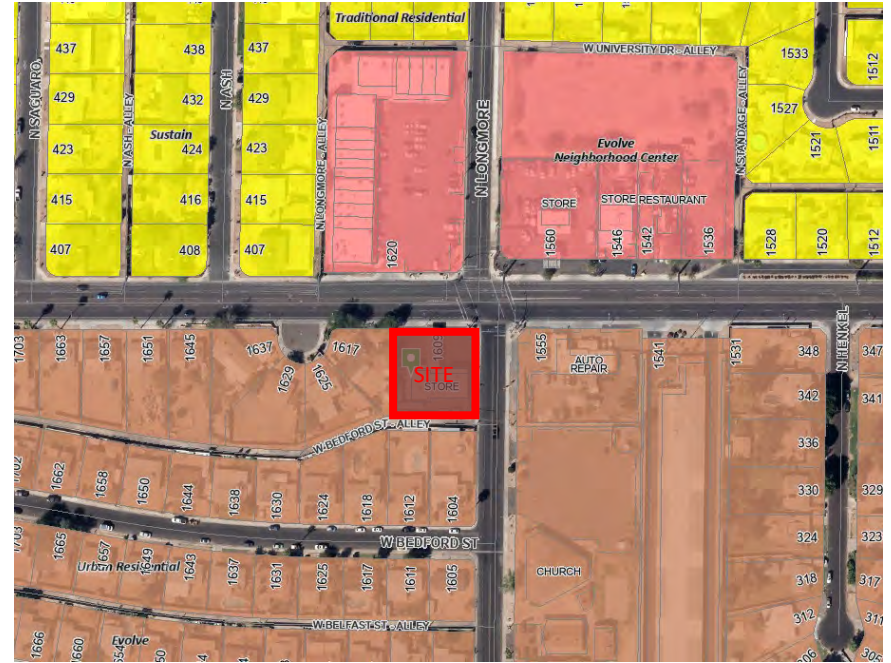

General Plan Context Map

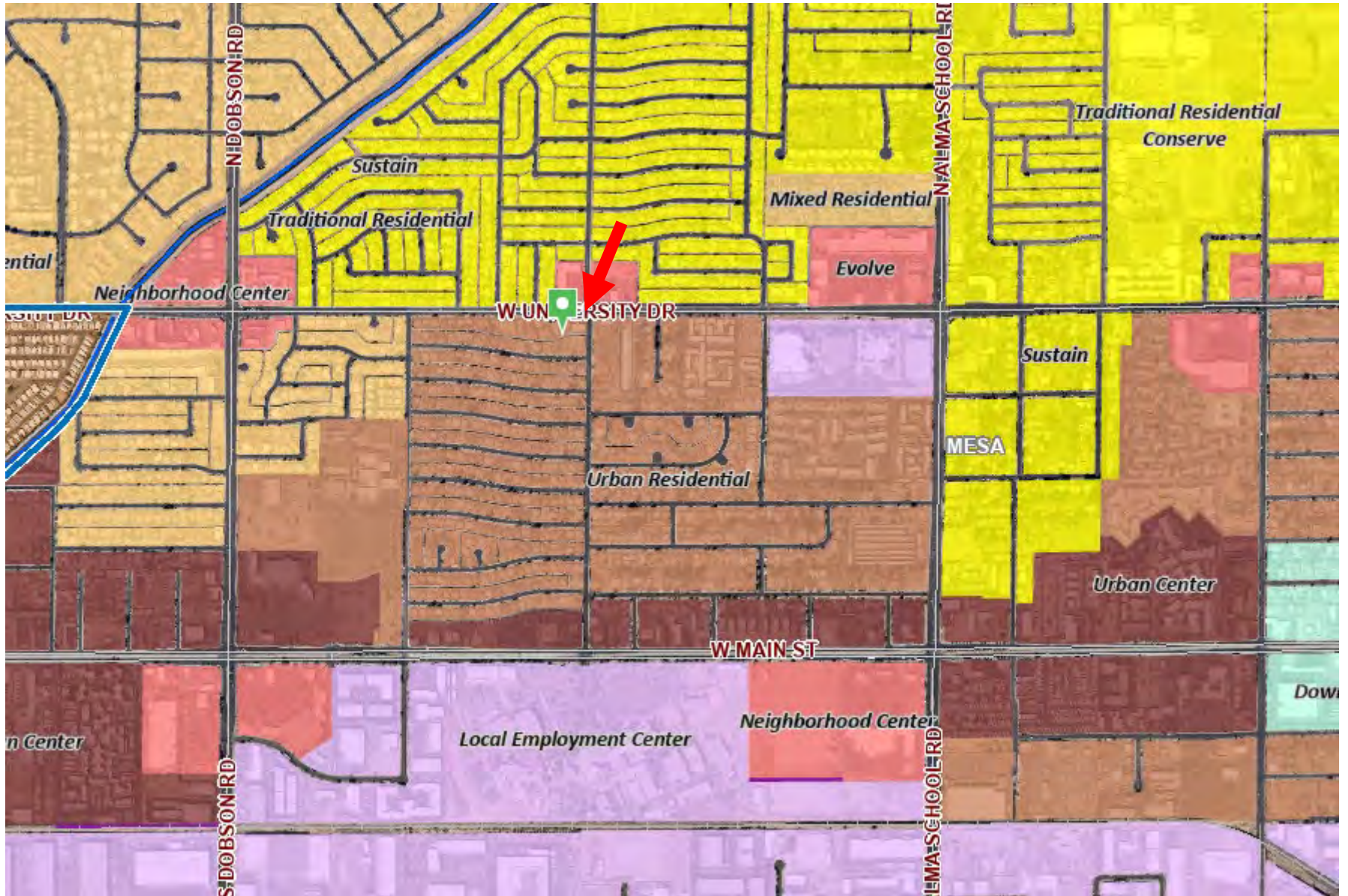

SWC University Dr and Longmore, Mesa



TAB C

West Main Street Area Plan

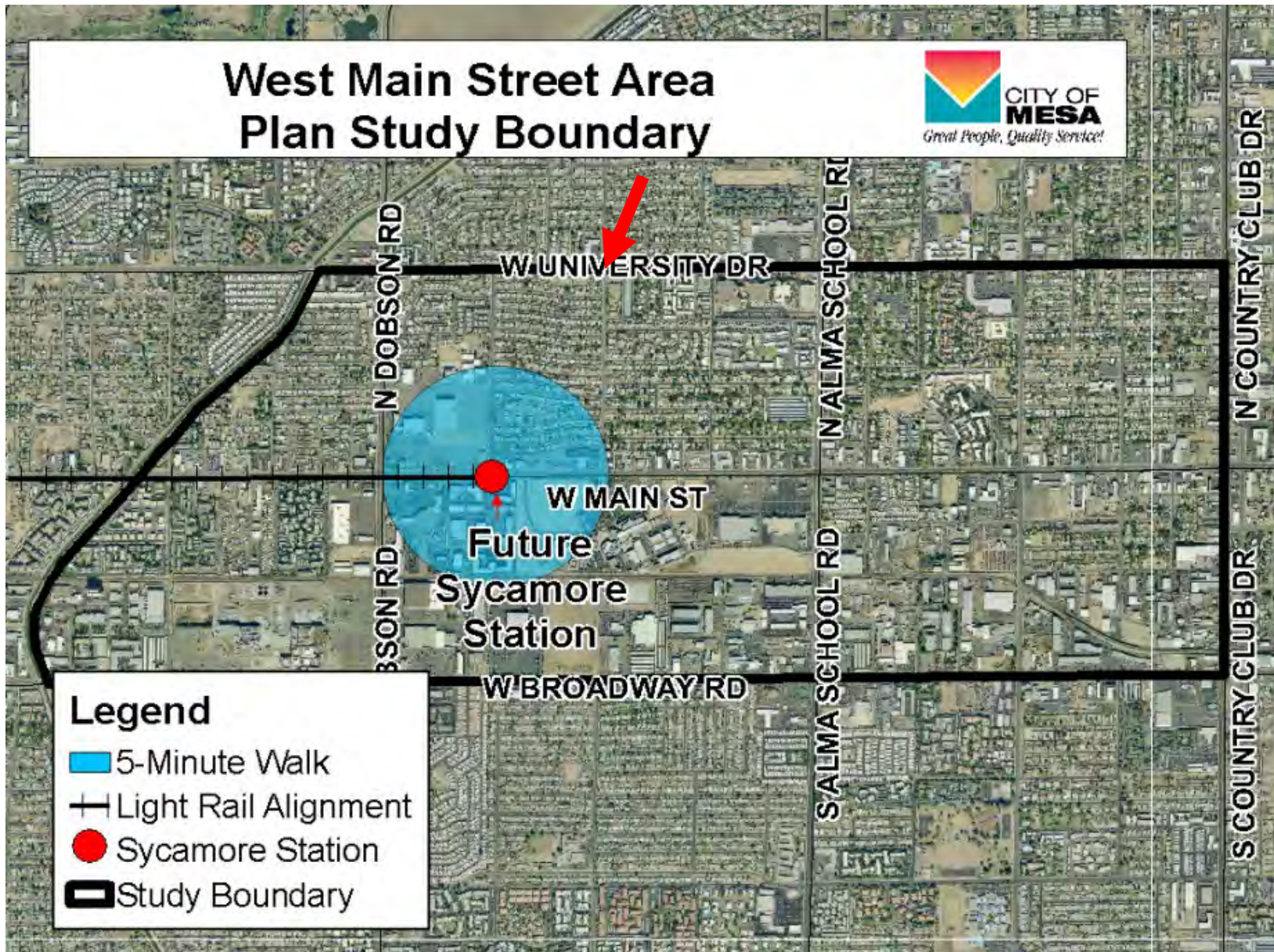

SWC University Dr and Longmore, Mesa



TAB D

Zoning Map

Existing Zoning: Office Commercial (OC)



Proposed Zoning: Limited Commercial (LC)



TAB E

COVER SHEET

FOR THE PROPERTY OF
 1609 W. UNIVERSITY DRIVE, MESA, AZ. 85201
"SAN ANTONIO TIRE SHOP"
 LOCATED IN A PORTION OF THE
 SOUTHEAST QUARTER OF SECTION 21, TOWNSHIP 1 NORTH, RANGE 4 EAST, GILA AND SALT
 RIVER MERIDIAN, MARICOPA COUNTY, ARIZONA

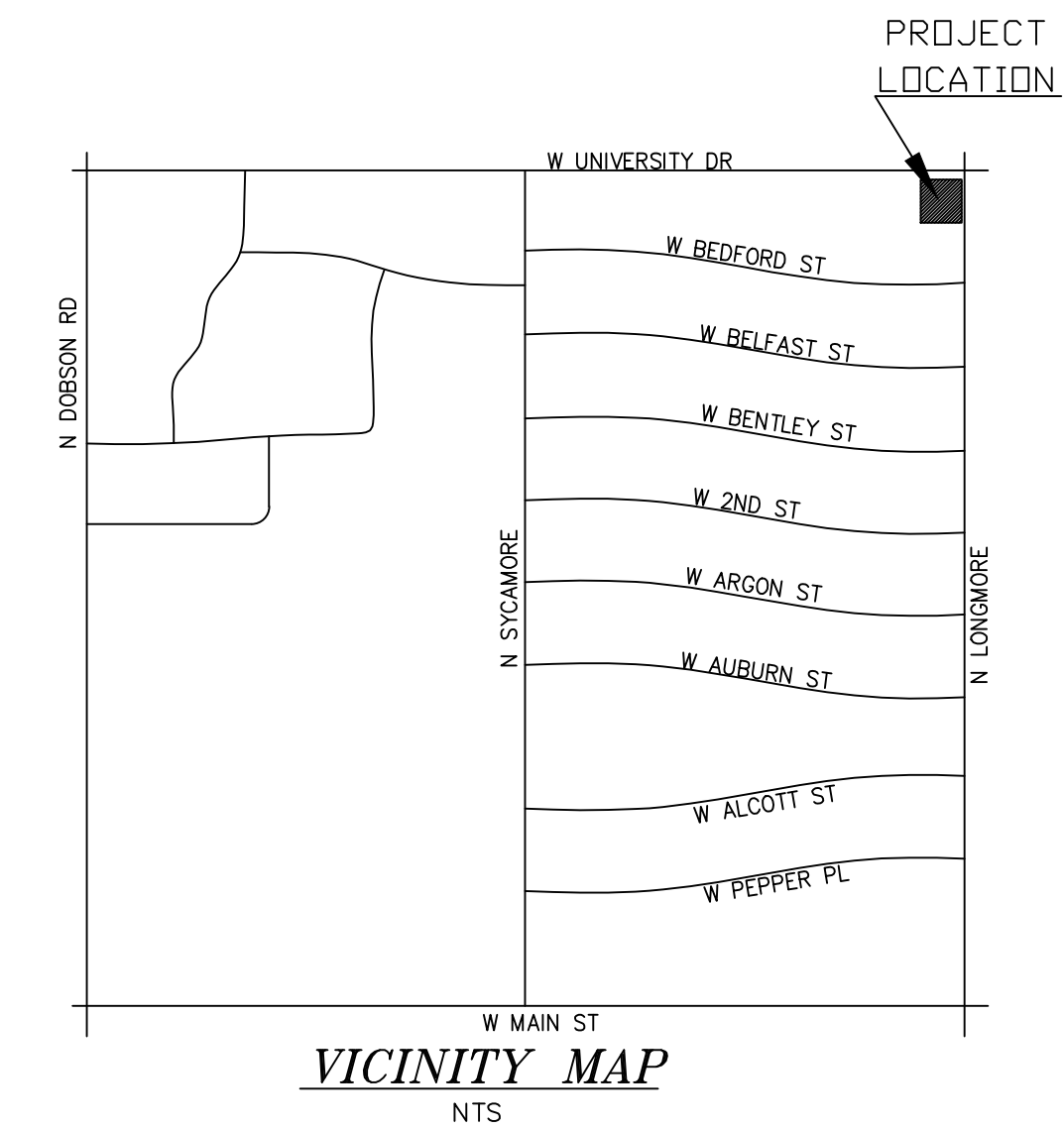

CITY OF MESA GENERAL NOTES

- ALL WORK AND MATERIALS SHALL CONFORM TO THE CURRENT UNIFORM STANDARD SPECIFICATIONS AND DETAILS FOR PUBLIC WORKS CONSTRUCTION AS FURNISHED BY THE MARICOPA ASSOCIATION OF GOVERNMENTS AND AS AMENDED BY THE CITY OF MESA. ALL WORK AND MATERIALS NOT IN CONFORMANCE WITH THESE AMENDED SPECIFICATIONS AND DETAILS ARE SUBJECT TO REMOVAL AND REPLACEMENT AT THE CONTRACTOR'S EXPENSE.
- SEPARATE RIGHT-OF-WAY PERMITS ARE REQUIRED FOR ALL PUBLIC UTILITIES, PUBLIC STREET IMPROVEMENTS, AND RIGHT-OF-WAY LANDSCAPING. FOR INFORMATION REGARDING AVAILABILITY AND COST OF RIGHT-OF-WAY PERMITS, CONTACT THE DEVELOPMENT SERVICES DEPARTMENT AT (480) 644-4273 OR AT [HTTP://WWW.MESA.AZ.GOV/DEVSUSTAIN/CONSTRUCTIONPERMITS.ASPX](http://www.mesaaz.gov/devsustain/constructionpermits.aspx). THE CONTRACTOR SHALL OBTAIN ALL PERMITS REQUIRED UNLESS OTHERWISE NOTED. CONTRACTORS MUST HOLD THE APPROPRIATE CLASS OF LICENSE AND SHALL HAVE ON FILE WITH THE PERMIT SERVICES SECTION PROOF OF INSURANCE COVERAGE. PERMITS BECOME INVALID AND MUST BE UPDATED IF WORK HAS NOT BEGUN WITHIN NINETY (90) DAYS. PERMITS ALSO BECOME INVALID IF THE CONTRACTOR'S INSURANCE LAPSES OR IS VOIDED.
- TWENTY FOUR (24) HOURS PRIOR TO THE COMMENCEMENT OF ANY WORK, CONSTRUCTION OR INSTALLATIONS ASSOCIATED WITH THIS PERMIT, THE PERMITTEE SHALL NOTIFY CITY OF MESA ENGINEERING DEPARTMENT AT (480) 644-2251 OF INTENT TO BEGIN AND REQUEST/SCHEDULE PRELIMINARY FIELD REVIEW AT THE PROJECT SITE WITH THE CITY OF MESA ENGINEERING DEPARTMENT CONSTRUCTION INSPECTOR (CITY INSPECTOR). FAILURE TO PROVIDE PROPER INSPECTION NOTIFICATION AS PRESCRIBED ABOVE SHALL RESULT IN THIS PERMIT BECOMING INVALID AND WORK BEING STOPPED.
- CONTRACTOR'S SHALL COMPLY WITH THE REQUIREMENTS TO OBTAIN THE NECESSARY RIGHT-OF-WAY PERMITS AND SHALL COMPLY WITH THE RIGHT-OF-WAY PERMIT CONDITIONS AS FOUND ON THE BACK OF THE PERMIT FORM.
- THE CITY OF MESA PARKS & RECREATION DIVISION IS NOT REPRESENTED BY BLUE STAKE. WHEN THE CONTRACTOR EXCAVATES NEAR OR ADJACENT TO A CITY PARK, THE CONTRACTOR SHALL CONTACT THE PARKS & RECREATION ADMINISTRATION SECTION AT (480) 644-2354 TO REQUEST ASSISTANCE IN LOCATING ALL THEIR UNDERGROUND FACILITIES.
- THE CONTRACTOR SHALL OBTAIN AN EARTH-MOVING PERMIT FROM THE MARICOPA COUNTY ENVIRONMENTAL SERVICES DEPARTMENT AND SHALL COMPLY WITH ITS REQUIREMENTS FOR DUST CONTROL.
- THE ENGINEER HEREBY CERTIFIES AS EVIDENCED BY A PROFESSIONAL SEAL & SIGNATURE, THAT ALL AFFECTED UTILITY COMPANIES BOTH PUBLIC AND PRIVATE HAVE BEEN CONTACTED AND ALL EXISTING AND/OR PROPOSED UTILITY LINES AND OTHER RELATED INFORMATION HAVE BEEN TRANSFERRED ONTO THESE PLANS. THE ENGINEER OR ARCHITECT ALSO HEREBY CERTIFIES THAT ALL EXISTING AND/OR PROPOSED PUBLIC RIGHT-OF-WAY AND EASEMENTS HAVE BEEN CORRECTLY PLOTTED/SHOWN.

CITY OF MESA PUBLIC STREET/RIGHT-OF-WAY IMPROVEMENT NOTES

- THE DEVELOPER AND THE CONTRACTOR ARE REQUIRED TO COORDINATE THE PLACEMENT OR INSTALLATION OF DRIVEWAYS IN ORDER TO AVOID CONFLICT WITH UTILITY SERVICES.
- ALL FRAMES, COVERS, VALVE BOXES, MANHOLES, ETC., SHALL BE INSTALLED TO FINISH GRADE OR SHALL BE ADJUSTED TO FINISH GRADE AFTER PLACING OF ASPHALTIC SURFACE COURSE BY THE CONTRACTOR PER M.A.G. STANDARD DETAIL 270 AND 422.
- THE CONTRACTOR SHALL ADJUST ALL FRAMES, COVERS, VALVE BOXES, MANHOLES, ETC. THAT ARE LOCATED WITHIN THE PARKWAY AREA AFTER FINAL GRADING AND INSTALLATION OF LANDSCAPING.
- ALL LANDSCAPING IMPROVEMENTS, INCLUDING IRRIGATION SYSTEMS WITHIN THE PUBLIC RIGHT-OF-WAY OR RETENTION BASINS THAT ARE TO BE MAINTAINED BY THE CITY OF MESA, SHALL BE IN ACCORDANCE WITH THE LANDSCAPING AND IRRIGATION STANDARDS BOOKLET.
- THE STREET PAVING PERMITTEE/CONTRACTOR IS HEREBY NOTIFIED THAT IN THE EVENT THAT ACCEPTANCE OF THE PUBLIC STREET PAVING IS DELAYED; SIX MONTHS OR MORE AFTER THE PAVEMENT WAS INSTALLED, THE PERMITTEE/CONTRACTOR SHALL APPLY A SEAL COAT TO THE PAVEMENT. TYPE OF MATERIAL AND RATE OF APPLICATION WILL BE DIRECTED BY THE CITY OF MESA ENGINEERING DEPARTMENT.
- A STANDARD RESIDENTIAL DRIVEWAY APPROACH SHALL BE CONSTRUCTED TO A MAXIMUM WIDTH OF 30 FEET UNLESS SPECIAL APPROVAL HAS BEEN OBTAINED.

PROJECT INFORMATION

PROJECT NAME: SAN ANTONIO TIRE SHOP
 PROJECT DESCRIPTION: EXISTING TIRE REPAIR & SERVICE
 PROJECT ADDRESS: 1609 W. UNIVERSITY DRIVE, MESA AZ 85201
 OWNER/DEVELOPER: TRES HERMANOS LLC
 OWNER CONTACT INFO: 734 E. MOBILE LANE, PHOENIX AZ 85040
 CONTRACTOR: ALL RIGHT BUILDERS, INC. MR. LEE PRICE
 allrightbuilders@cox.net
 APN: 135-63-116
 TOTAL LAND AREA: 16,911 SF / 0.39 ACRE
 ZONING: LC (C-2) (COMMERCIAL/DISTRICT)
 CONSTRUCTION TYPE: 8" BLOCK/BRICK
 MCR: 89-05
 SUBDIVISION: CASA MESA AMENDED LOT 1-58, 135-191, TR A
 LOT: 16,911 SF
 BUILDING SIZE: 4,015 SF
 BUILDING SETBACKS: 15' FRONT (ST), 25' REAR, 25' SIDE & 15' SIDE (ST)
 LANDSCAPE SETBACKS: 5' FRONT, 5' REAR AND 5' SIDES
 BUILDING HEIGHT: MAXIMUM 2 STORIES AND 30FT TALL
 LOT COVERAGE: 13,050/ 16,911 SF = 77% - ALLOWED=80%

PARKING REQUIREMENTS

PER CITY OF MESA
 - 1.0 SPACE PER 375 SF
 - 1 ADA PARKING PER 1-25 PARKING SPACES
 - TOTAL REQUIRED: 11 PARKING SPACES INCLUDING 1 ADA SPACE
 - TOTAL PROVIDED: 4 PARKING SPACES INCLUDING 1 ADA SPACE

LANDSCAPE REQUIREMENTS

PER CITY OF MESA
 - LANDSCAPE SETBACK(S) 5' FRONT, 5' REAR AND 5' SIDES
 - LANDSCAPE PROVIDED - AREA = 3,456 SF OR 20.49%

ENGINEER

SAIF ENGINEERING LLC
 8011 S Avenida del Yaqui
 Guadalupe, AZ 85283
 (602) 954-2161
 (602) 773-1833 FAX

APPLICABLE CODE:

2018 INTERNATIONAL RESIDENTIAL CODE (IRC)
 2018 INTERNATIONAL BUILDING CODE (IBC)
 2018 INTERNATIONAL FIRE CODE (IFC)
 2018 INTERNATIONAL MECHANICAL CODE (IMC)
 2018 INTERNATIONAL PLUMBING CODE (IPC)
 2018 INTERNATIONAL FUEL GAS CODE (IFGC)
 2018 INTERNATIONAL ENERGY CONSERVATION CODE (IECC)
 2018 INTERNATIONAL SWIMMING POOL AND SPA CODE (ISpsc)
 2018 INTERNATIONAL EXISTING BUILDING CODE (IEBC)
 2017 NATIONAL ELECTRIC CODE (NEC)
 A117.1 2009 ACCESSIBLE AND USABLE BUILDINGS AND FACILITIES
 CITY OF MESA - AMENDED FIRE CODE

SHEET INDEX

A1 COVER SHEET
 A2 EXISTING SITE PLAN
 A3 PROPOSED SITE PLAN

PROJECT MANAGER:	BY
DATE	REVIEW
DESIGN BY: R.M.S.	
DRAWN BY: N.S.Q	
CHECKED BY: R.M.S.	
DATE:	

SAIF ENGINEERING L.L.C.
 Engineering, Surveying & Construction Administration
 8011 S Avenida del Yaqui
 Guadalupe, AZ 85283, Tel: 954-2161 Fax: (602) 773-1833

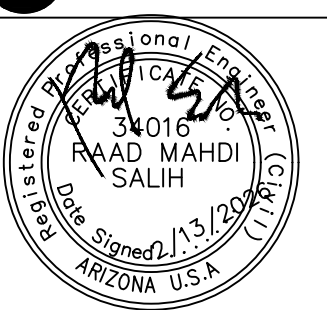

EXPIRES 09/30/26

COVER
 NEW TENANT IMPROVEMENT PLANS
 TRES HERMANOS LLC'S
 "SAN ANTONIO TIRE SHOP"
 1609 W. UNIVERSITY DRIVE, MESA, AZ

SECTION: 30
 TOWNSHIP: 1N
 RANGE: 2E

JOB NO.:

SHEET
 A1 OF A4



EXISTING SITE/ SURVEY PLAN

FOR THE PROPERTY OF
1609 W. UNIVERSITY DRIVE, MESA, AZ. 85201
"SAN ANTONIO TIRE SHOP"

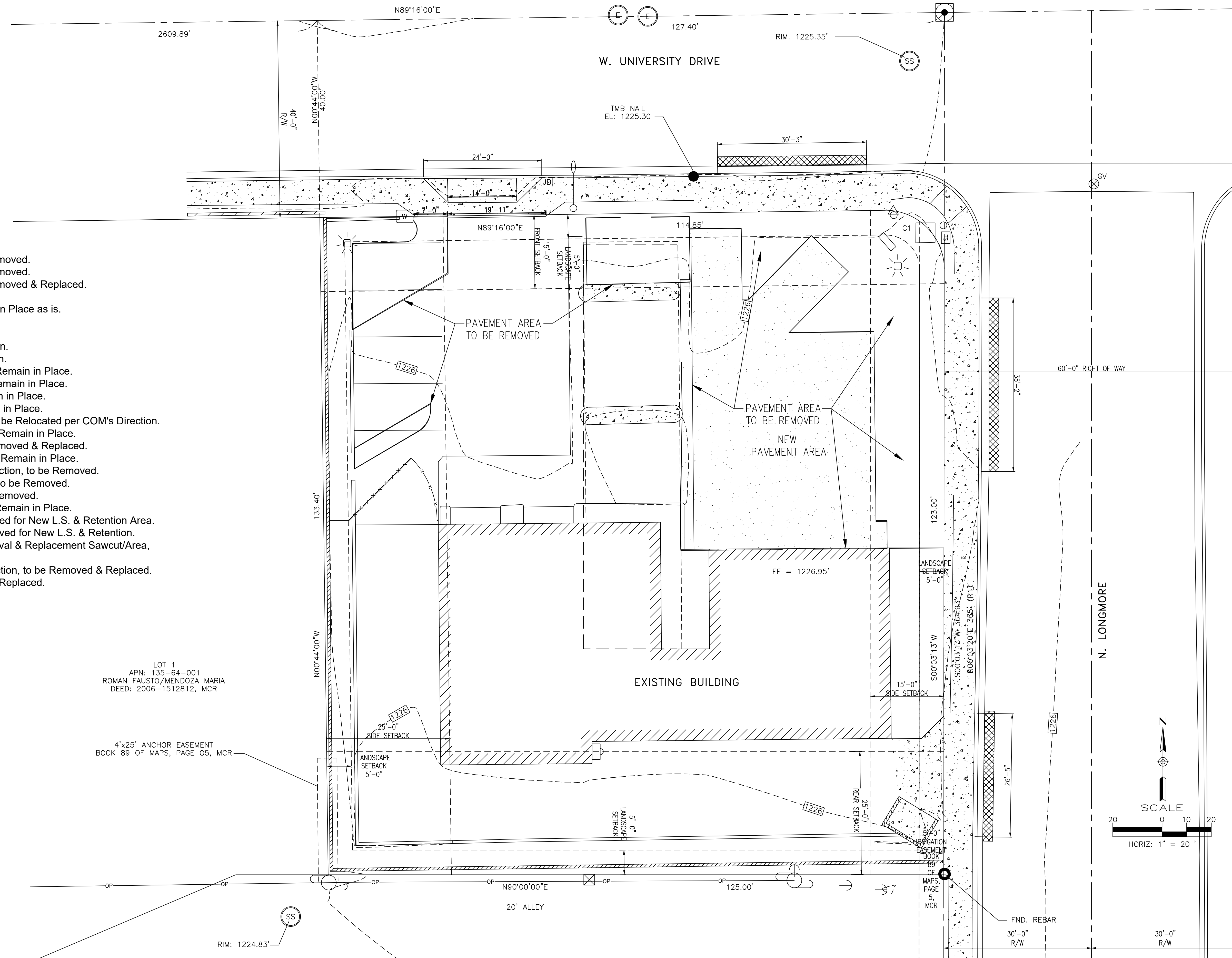

KEY NOTES

1. Existing Property Line.
2. Existing 5' High Block Property Wall.
3. Existing 14' Wide Driveway.
4. Existing 30' Wide Driveway, to be Removed.
5. Existing 35' Wide Driveway, to be Removed.
6. Existing 26' Wide Driveway, to be Removed & Replaced.
7. Existing Utility Pole, to Remain.
8. Existing Trash Enclosure, to Remain in Place as is.
9. Existing 6" Vertical Curb & Gutter.
10. Existing 5' Wide Concrete Sidewalk.
11. Existing Street Light & Pole, to Remain.
12. Existing Site's Water Meter, to Remain.
13. Existing Overhead Property Sign, to Remain in Place.
14. Existing Concrete Irrigation Box, to Remain in Place.
15. Existing Traffic Signal Pole, to Remain in Place.
16. Existing Traffic Signal Box, to Remain in Place.
17. Existing PED Traffic Signal Button, to be Relocated per COM's Direction.
18. Existing Site/Parking Light & Pole, to Remain in Place.
19. Existing Concrete Walkway, to be Removed & Replaced.
20. Existing 6" Vertical Concrete Curb, to Remain in Place.
21. Existing 6" Vertical Concrete Curb Section, to be Removed.
22. Existing 6' High Metal & Wood Gate, to be Removed.
23. Existing 6' High Wood Fence, to be Removed.
24. Existing Electrical Panel & Meter, to Remain in Place.
25. Existing Pavement Area to be Removed for New L.S. & Retention Area.
26. Existing L.S. Gravel Area to be Removed for New L.S. & Retention.
27. Existing 2' Wide Street Section Removal & Replacement Sawcut/Area, per C.O.M. Stdl Dtl M-19.01.
28. Existing 6" Vertical Curb & Gutter Section, to be Removed & Replaced.
29. Existing Pavement to be Removed & Replaced.

LOT 1
APN: 135-64-001
ROMAN FAUSTO/MENDOZA MARIA
DEED: 2006-1512812, MCR

4'x25' ANCHOR EASEMENT
BOOK 89 OF MAPS, PAGE 05, MCR

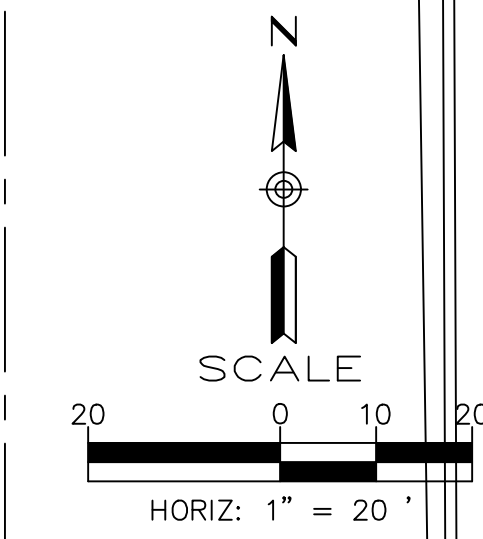

PROJECT MANAGER:	DATE:
DESIGN BY: R.M.S.	CHECKED BY: R.M.S.
DRAWN BY: N.S.Q	DATE:
REVIEW:	
BY:	

AIF ENGINEERING L.L.C.
Engineering, Surveying & Construction Administration
8011 S. Avenida del Yocul
Guadalupe, AZ 85285, Tel 954-261 Fax (602) 775-1833

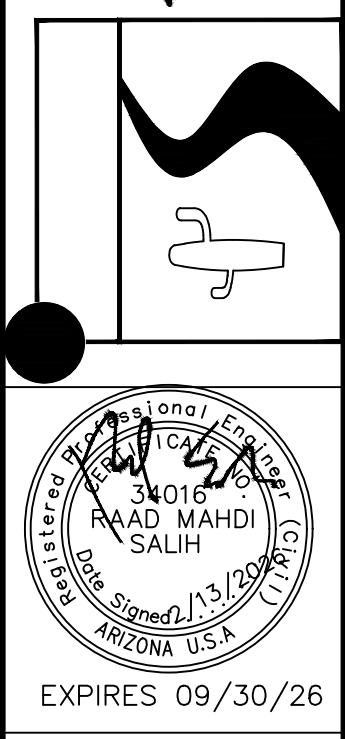

EXISTING SITE PLAN
TRES HERMANOS LLC'S
"SAN ANTONIO TIRE SHOP"
1609 W. UNIVERSITY DRIVE, MESA, AZ

SCALE:
NOTED
SECTION: 30
TWNHP: 1N
RANGE: 2E
JOB NO.:
-
SHEET
A2 OF A4



PROPOSED SITE PLAN

FOR THE PROPERTY OF
1609 W. UNIVERSITY DRIVE, MESA, AZ. 85201
"SAN ANTONIO TIRE SHOP"

PROJECT INFORMATION

PROJECT NAME: SAN ANTONIO TIRE SHOP
 PROJECT DESCRIPTION: EXISTING TIRE REPAIR & SERVICE
 PROJECT ADDRESS: 1609 W. UNIVERSITY DRIVE, MESA AZ 85201
 OWNER/DEVELOPER: TRES HERMANOS LLC
 OWNER CONTACT INFO: 734 E. MOBILE LANE, PHOENIX AZ 85040
 CONTRACTOR: ALL RIGHT BUILDERS, INC.
 MR. LEE PRICE
 allrightbuilders@cox.net
 135-63-116
 APN: 16,911 SF / 0.39 ACRE
 ZONING: LC (C-2) (COMMERCIAL DISTRICT)
 CONSTRUCTION TYPE: 8" BLOCK/BRICK
 MCR: 89-05
 SUBDIVISION: CASA MESA AMENDED LOT 1-58, 135-191, TR
 BUILDING SIZE: 4,015 SF
 BUILDING SETBACKS: 15' FRONT (ST), 25' REAR, 25' SIDE & 15' SIDE (ST)
 LANDSCAPE SETBACKS: 5' FRONT, 5' REAR AND 5' SIDES
 BUILDING HEIGHT: MAXIMUM 2 STORIES AND 30FT TALL
 LOT COVERAGE: 13,050/ 16,911 SF = 77% - ALLOWED=80%

PARKING REQUIREMENTS

PER CITY OF MESA
 - 1.0 SPACE PER 375 SF
 - 1 ADA PARKING PER 1-25 PARKING SPACES
 - TOTAL REQUIRED: 11 PARKING SPACES INCLUDING 1 ADA SPACE
 - TOTAL PROVIDED: 4 PARKING SPACES INCLUDING 1 ADA SPACE

LANDSCAPE REQUIREMENTS

PER CITY OF MESA
 - LANDSCAPE SETBACK(S) 5' FRONT, 5' REAR AND 5' SIDES
 - LANDSCAPE PROVIDED - AREA = 3,456 SF OR 20.49%

NEW "SPLIT-FACE" BLOCK SCREEN WALLS			
DETAIL #	W. HEIGHT	W. LENGTH	LOCATIONS
(N)	3'-4" to 3'-4"	14'-9"	Along UNIVERSITY - From 10' E/D Drwy, EAST
(N)	3'-4" to 3'-4"	10'-0"	Along University dr - From 8.5 W/D Drwy, WEST
(N)	3'-4" to 3'-4"	4'-0"	Along University dr - WEST TO N3
(N)	3'-4" to 3'-4"	2'-0"	From end of N2 - SOUTH 2.00' to N4
(N)	3'-4" to 3'-4"	20'-0"	From end of N3 - WEST 20.00' to N5
(N)	3'-4" to 3'-4"	2'-0"	From end of N4 - SOUTH 2.00' to N6
(N)	3'-4" to 3'-4"	20'-0"	From end of N5 - WEST 20.00' to N7
(N)	3'-4" to 3'-4"	2'-0"	From end of N6 - SOUTH 2.00' to N8
(N)	3'-4" to 3'-4"	4'-9"	From end of N4 - WEST 4.80' to the end
(N)	3'-4" to 3'-4"	7'-1"	6'-0" SW/O& parallel to Curb-L21 - SOUTHEAST 7.08' to NE2
(N)	3'-4" to 3'-4"	7'-0"	From end of SE1 - SOUTH 7.00' to SE3
(N)	3'-4" to 3'-4"	11'-9"	From end of SE2 - SOUTHEAST 11.75' to End
(E)	3'-4" to 3'-4"	9'-7"	6'-0" W/O& Parallel to Curb- L18 - SOUTH 9.75' to S2
(E)	3'-4" to 3'-4"	2'-0"	From end of S1 - EAST 2.00' to S3
(E)	3'-4" to 3'-4"	20'-11"	From end of S2 - SOUTH 20.92' to S4
(E)	3'-4" to 3'-4"	2'-0"	From end of S3 - WEST 2.00' to S5
(E)	3'-4" to 3'-4"	9'-0"	From end of S4 - SOUTH 9.00' to End.

TOTAL = 148'-9" LF

KEY NOTES

- Existing Property Line.
- Existing 5' High Block Property Wall to be raised to 6'.
- Existing 14' Wide Driveway.
- Existing 30' Wide Driveway, to be Removed.
- Existing 35' Wide Driveway, to be Removed.
- Existing 26' Wide Driveway, to be Removed & Replaced.
- Existing Utility Pole, to Remain in Place.
- Existing Trash Enclosure, to Remain in Place as is.
- Existing Concrete Vertical Curb & Gutter.
- Existing 5' Wide Concrete Sidewalk.
- Existing Street Light & Pole, to Remain in Place.
- Existing Site's Water Meter, to Remain in Place.
- Existing Overhead Property Sign, to Remain in Place.
- Existing Concrete Irrigation Box, to Remain in Place.
- Existing Traffic Signal Pole, to Remain in Place.
- Existing Traffic Signal Box, to Remain in Place.
- Existing PED Traffic Signal Button, to be Relocated per COM's Direction.
- Existing Site/Parking Light & Pole, to Remain in Place.
- Existing Concrete Walkway, to be Removed & Replaced.
- Existing 6" Vertical Concrete Curb, to Remain in Place.
- Existing 6" Vertical Concrete Curb Section, to be Removed.
- Existing Electrical Panel & Meter, to Remain in Place.
- Existing 2' Wide Street Section Removal & Replacement Sawcut/Area, per C.O.M. Std Dtl M-19.01.
- New 6" Vertical Curb & Gutter Section, per M.A.G. Std. Dtl. 220-1, Type "A".
- New 6" Concrete Single Curb, per M.A.G. Std. Dtl. 222, Type "A".
- New 2' Wide Curb Opening, per Curb Opening Detail on Sht-CX.
- New 3' Wide Rip-Rap Spillway, per Spillway Detail on Sht-CX.
- New 5' Wide Sidewalk Section, per M.A.G. Std. Dtl. 230.
- New 5' Wide Walkway Section, per M.A.G. Std. Dtl. 230.
- New 25'-0" Wide Driveway Entrance/Exit, per C.O.M. Std. Dtl. M-40.01.
- New 6" Dia. Steel Guard Bollard, per M.A.G. Std. Dtl. 140, Type 2-Removable.
- New Accessible Parking Stripping, per Accessible Parking Detail on Sht-C6
- New 6" Dia. PVC Drainage Equalizer Pipe.
- New Retention Basin.
- New Asphalt Pavement Driveway, @ 3" Thick/8" A.B.C.
- New 8" Thick Concrete Section.
- New EXIT Driveway Sight Visibility Triangle.
- New Pavement Section, to match Existing & Proposed Grades.
- NEW 40" HIGH CMU BREEZE BLOCK SCREEN WALL., see Screen Wall Schedule.
- Install New ADA Ramp Per MAD STD DET 238-1
- New Bike Rack.
- Existing wall reduced to 3.5 ft within 15 ft of street property line to comply with MZO Section 11-30-9(F)(2)(d).
- EXISTING CANOPY
- INTERNAL PEDESTRIAN CROSSWALKS TO BE RAISED A MINIMUM OF 3 INCHES ABOVE THE VEHICULAR PAVEMENT AND TO BE CONSTRUCTED OF PAVERS, COLORED CONCRETE, OR STAMPED CONCRETE PER CITY REQUIREMENTS (TYP.).
- ALLEY TO BE SURFACED WITH A MINIMUM OF 4" AGGREGATE BASE COURSE (A.B.C.) PER MAG STANDARD DETAIL 202.
- 40" HIGH METAL SCREEN WALL

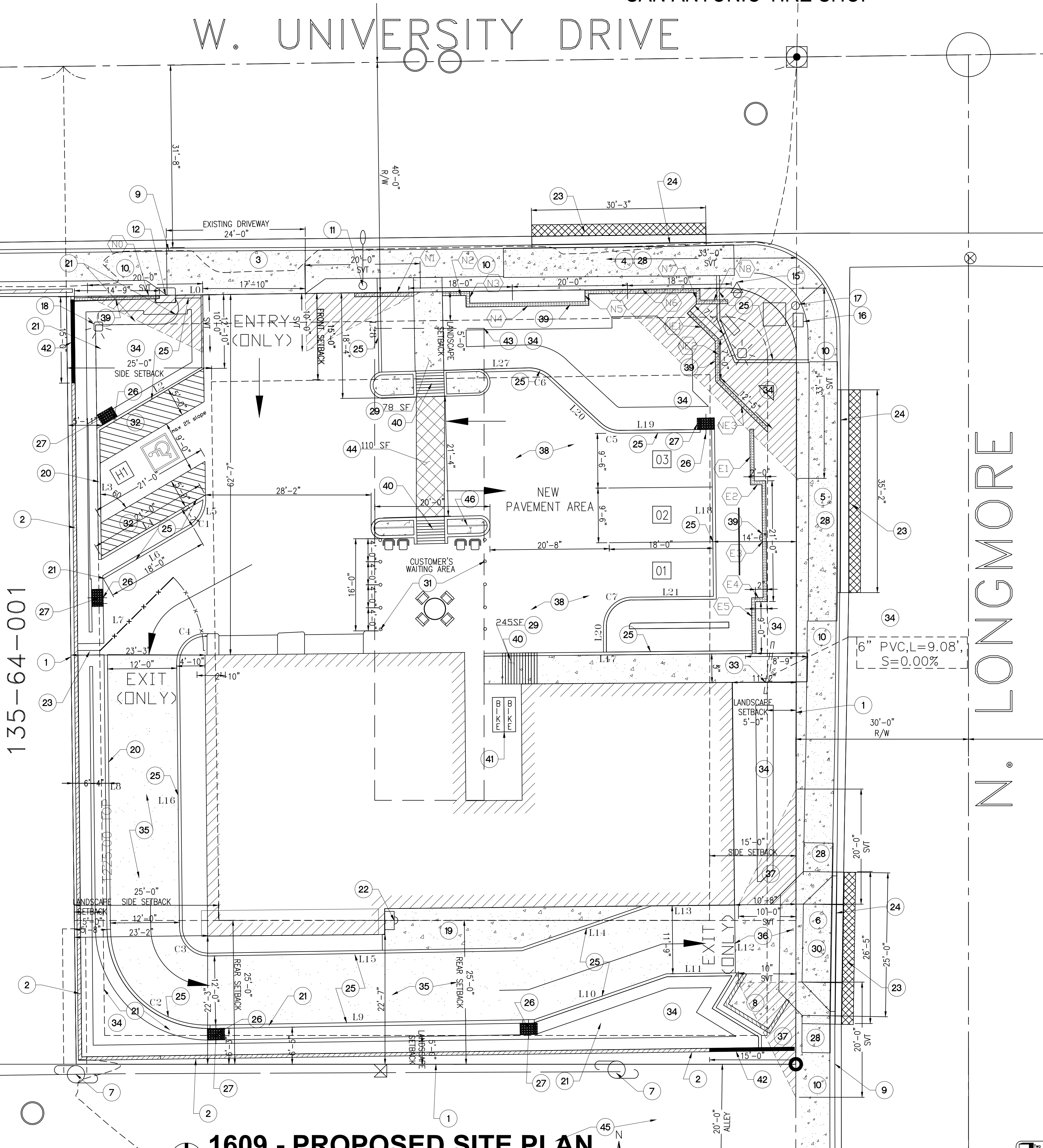

LINE TABLE - CONCRETE PAVEMENT		
LINE	DISTANCE	REMARKS
L0	7'-0"	PARALLEL TO PL
L1	11'-7"	90° TO P.L.
L2	20'-2"	60° TO PL
L3	22'-0"	PARALLEL TO PL
L4	21'-0"	60° TO PL
L5	6'-0"	PARALLEL TO PL
L6	18'-10"	60° TO PL
L7	11'-3"	PARALLEL TO PL
L8	47'-8"	PARALLEL TO PL
L9	54'-3"	PARALLEL TO WALL
L10	24'-3"	19° TO WALL
L11	12'-3"	PARALLEL TO WALL
L12	11'-9"	PERPEND. TO BLDG
L13	14'-6"	BACK OF BLDG
L14	23'-8"	19° TO BLDG
L15	54'-5"	PARALLEL TO BLDG
L16	46'-0"	PARALLEL TO BLDG
L17	39'-2"	PARALLEL TO BLDG
L18	38'-6"	PARALLEL TO P.L.
L19	16'-0"	90° TO P.L.
L20	18'-0"	45° TO P.L.
L21	4'-6"	45° TO P.L.
L22	14'-0"	45° TO P.L.
L23	NOT USED	NOT USED
L24	NOT USED	NOT USED
L25	NOT USED	NOT USED
L26	NOT USED	NOT USED
L27	37'-10"	PARALLEL TO P.L.
L28	13'-7"	90° TO P.L.

TOTAL 588 L.F.

CURVE TABLE - CONCRETE PAVEMENT		
CURVE	RADIUS	ARC LENGTH
C1	5'-0"	5'-2"
C2	16'-9"	26'-9"
C3	3'-0"	4'-6"
C4	5'-0"	5'-2"
C5	5'-0"	3'-7"

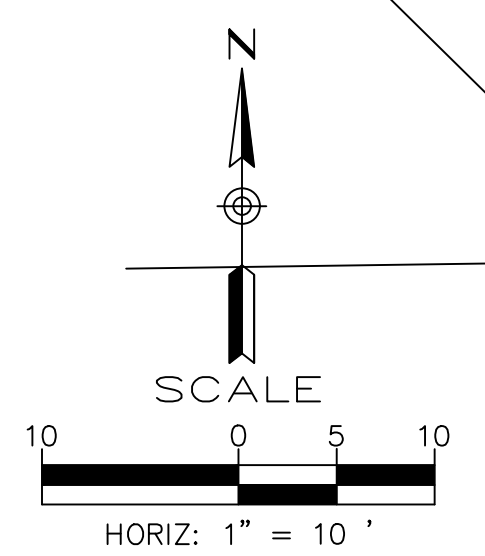

1609 - PROPOSED SITE PLAN
SCALE: 1" = 10'-0"

PROJECT MANAGER: _____
 DESIGN BY: R.M.S. _____
 DRAWN BY: N.S.Q. _____
 CHECKED BY: R.M.S. _____
 DATE: _____

AIF ENGINEERING L.L.C.
 Engineering, Surveying & Construction Administration
 8011 S. Avenida del Yacui
 Guadalupe, AZ 85283, Tel: 954-2161 Fax: (602) 773-1833

PAVING & DRAINAGE PLANS
TRES HERMANOS LLC'S
"SAN ANTONIO TIRE SHOP"
 1609 W. UNIVERSITY DRIVE, MESA, AZ

SCALE: NOTED
 SECTION: 30
 TWSHP: 1N
 RANGE: 2E
 JOB NO.: _____
 SHEET OF A4

WALL DETAILS

FOR THE PROPERTY OF
1609 W. UNIVERSITY DRIVE, MESA, AZ. 85201
"SAN ANTONIO TIRE SHOP"

- EXISTING CMU WALL ALONG INTERIOR LOT LINES TO BE RAISED TO 6 FT WHERE FEASIBLE.
- MAXIMUM HEIGHT OF 3.5 FT APPLIES WITHIN FIRST 15 FT OF STREET-FACING SIDE YARDS PER MZD SECTIONS 11-30-4(B) AND 11-30-9(I).

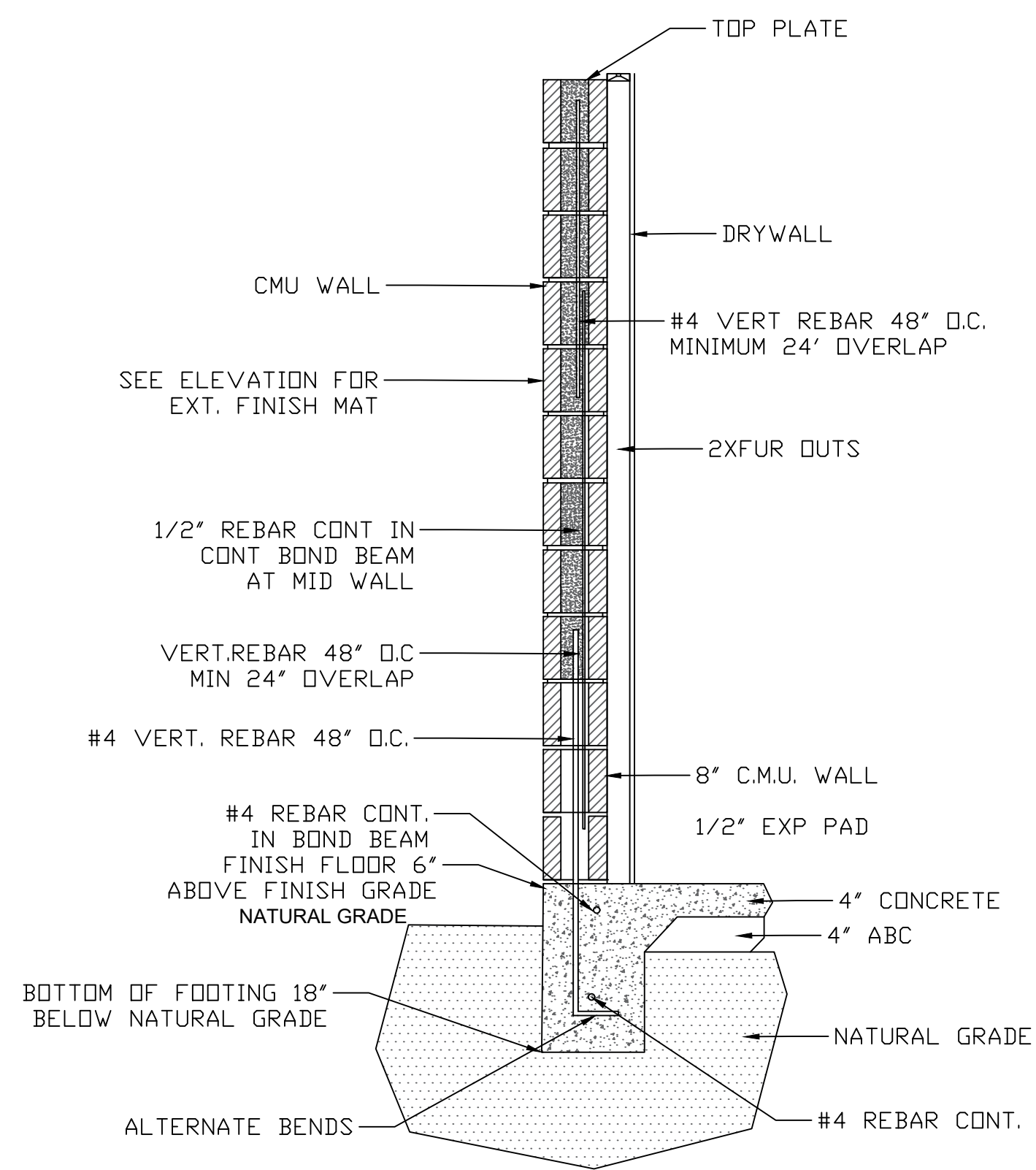

1 EXISTING EXTERIOR CMU WALL SECTION
SCALE: 3/4" = 1'-0"

NOTE: EXISTING CMU WALL CONSTRUCTION. DETAIL SHOWN DIAGRAMMATICALLY FOR CODE COMPLIANCE AND SOUND ATTENUATION VERIFICATION (MIN. 25 dB). NO NEW WALL CONSTRUCTION PROPOSED.

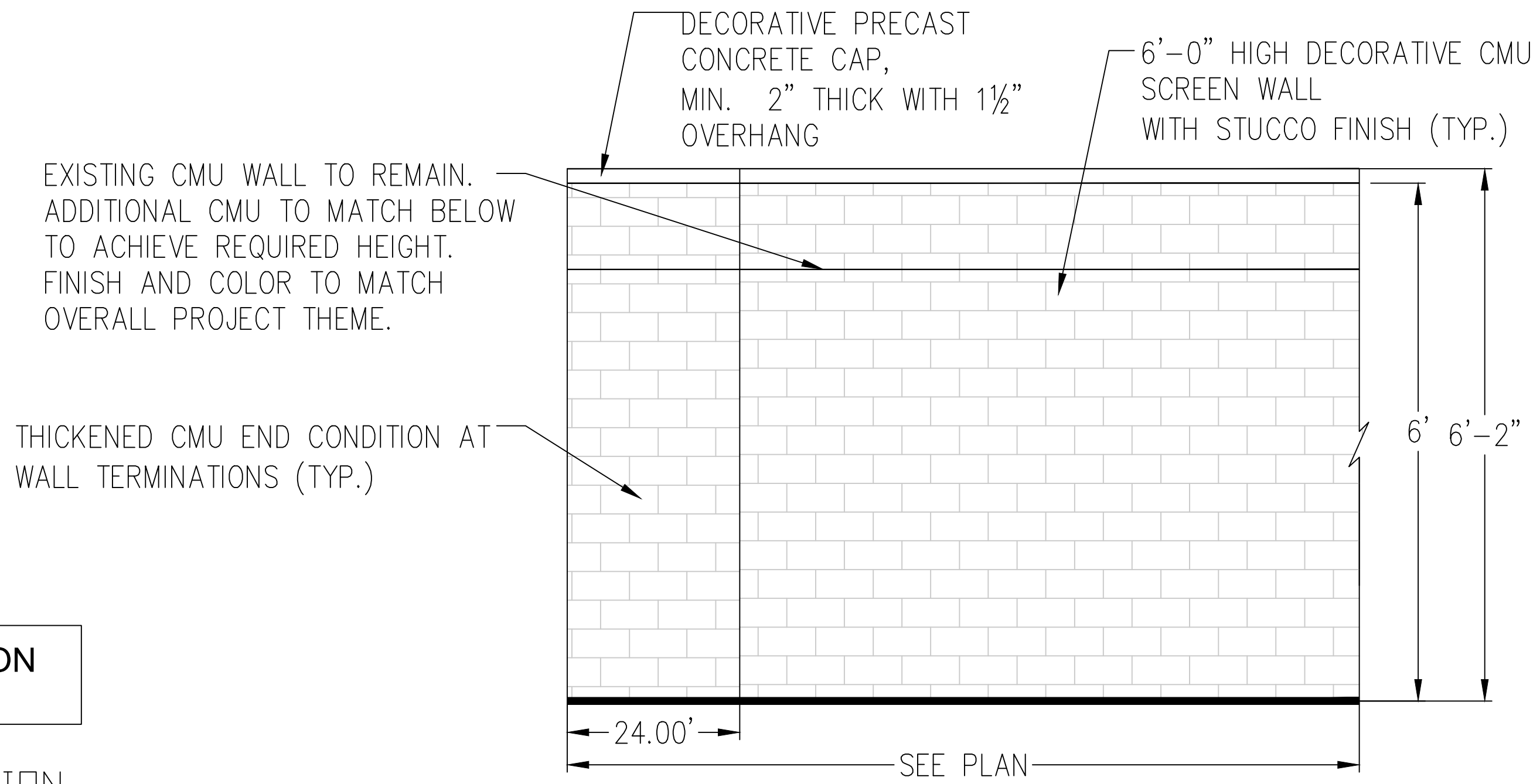

2 DECORATIVE WALL
SCALE: 3/4" = 1'-0"

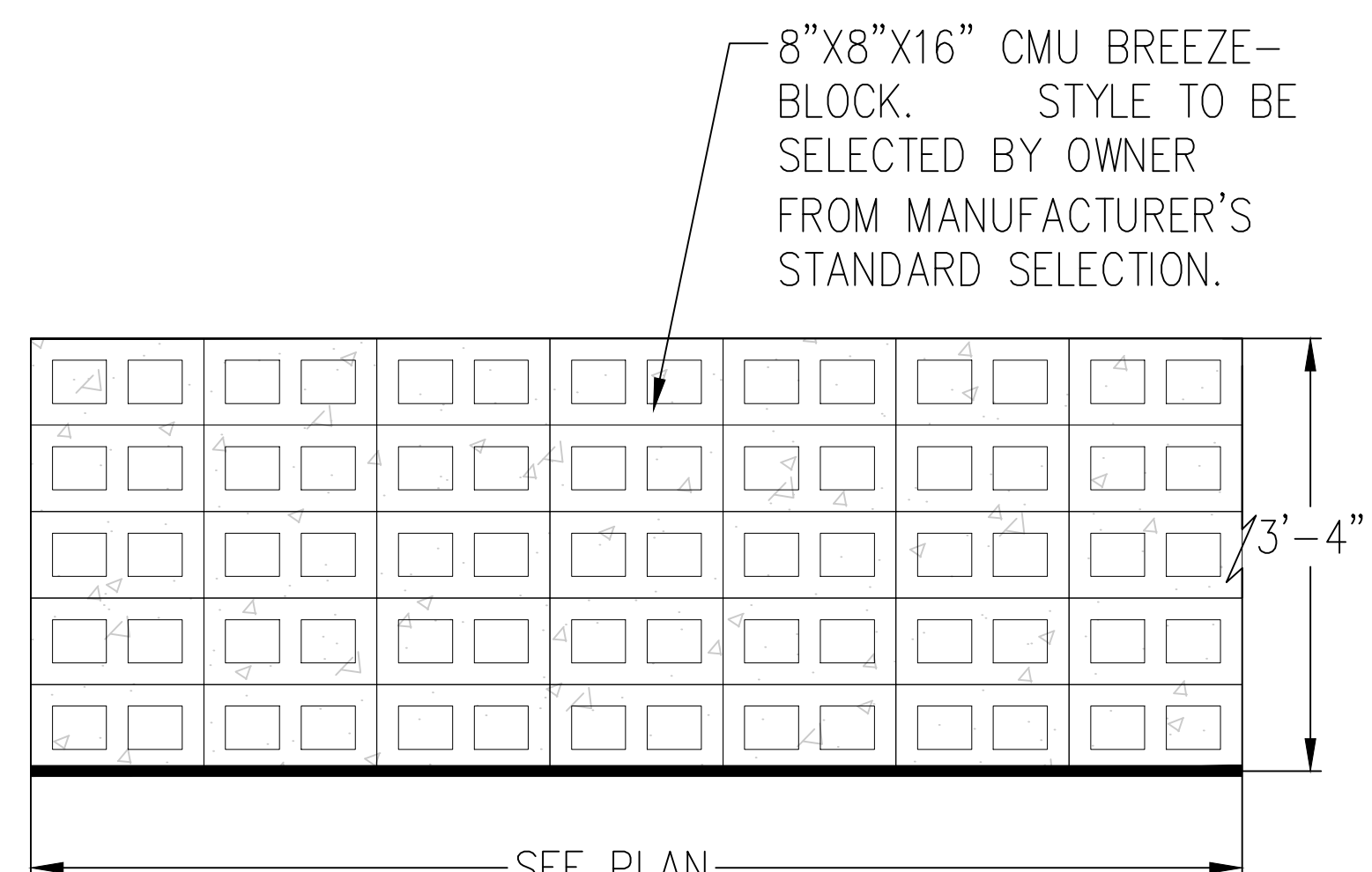

3 DECORATIVE WALL SECTION
SCALE: 3/4" = 1'-0"

- NOTES:
- OWNER TO SELECT INTEGRAL BLOCK AND PAINT COLOR.
 - CONTRACTOR TO PROVIDE SH DRAWINGS TO OWNER FOR A WALLS AND FOOTINGS.
 - STEP FOOTING WHERE APPROPRIATE.

4 40" DECORATIVE WALL
SCALE: 3/4" = 1'-0"

PROJECT MANAGER:	BY
DESIGN BY: R.M.S.	DATE
DRAWN BY: N.S.Q.	REVIEW
CHECKED BY: R.M.S.	
DATE:	

AIF ENGINEERING L.L.C.
Engineering, Surveying & Construction Administration
8011 S. Avenida del Yacui
Goodyale, AZ 85283, Tel: 954-2161 Fax: (602) 773-1833

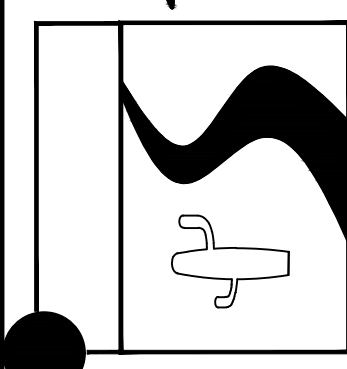

EXPIRES 09/30/26

WALL DETAILS
TRES HERMANOS LLC'S
"SAN ANTONIO TIRE SHOP"
1609 W. UNIVERSITY DRIVE, MESA, AZ

SCALE: NOTED
SECTION: 30
TWNHP: 1N
RANGE: 2E
JOB NO.:
SHEET OF A4



TAB F















TAB G

PROJECT INFORMATION

PROJECT NAME: SAN ANTONIO TIRE SHOP
 PROJECT DESCRIPTION: EXISTING TIRE REPAIR & SERVICE
 PROJECT ADDRESS: 1609 W. UNIVERSITY DRIVE, MESA AZ 85201
 OWNER/DEVELOPER: TRES HERMANOS LLC
 OWNER CONTACT INFO: 734 E. MOBILE LANE, PHOENIX AZ 85040
 CONTRACTOR: ALL RIGHT BUILDERS, INC. MR. LEE PRICE
 allrightbuilders@cox.net 335-63-1116
 APN: 16911 SF / 0.39 ACRE
 ZONING: LC (C-2) (COMMERCIAL/DISTRICT)
 CONSTRUCTION TYPE: 8" BLOCK/BRICK
 MCR: 89-05
 SUBDIVISION: CASA MESA AMENDED LOT 1-58, 135-191, TR A
 LOT: 4,015 SF
 BUILDING SIZE: 15' FRONT (ST), 20' REAR, 20' SIDE & 15' SIDE (ST)
 BUILDING SETBACKS: 5' FRONT, 5' REAR AND 5' SIDES
 LANDSCAPE SETBACKS: MAXIMUM 2 STORIES AND 30FT TALL
 BUILDING HEIGHT: MAXIMUM 2 STORIES AND 30FT TALL
 LOT COVERAGE: 13,050/ 16,911 SF = 77% - ALLOWED=80%

PARKING REQUIREMENTS

- PARKING REQUIREMENTS
- PER, CITY OF MESA
- 1.0 SPACE PER 375 SF
- 1 ADA PARKING PER 1-25 PARKING SPACES
- TOTAL REQUIRED: 11 PARKING SPACES INCLUDING 1 ADA SPACE
- TOTAL PROVIDED: 4 PARKING SPACES INCLUDING 1 ADA SPACE

LANDSCAPE REQUIREMENTS

PER, CITY OF MESA
 LANDSCAPE PROVIDED - AREA = 3,456 SF OR 20.49%
Landscape Plan Notes:
 The landscape plan provides more than 50% plant coverage as required (see table). All plant areas will be top-dressed with decomposed granite.
 See Site/Civil Plans for Wall Locations & Details

LANDSCAPE LEGEND

Trees	Plant Name	Size	Qty	Mature Tree Crown Dia	Type of Plant Material	Credit in SF	Total Credit in SF
Trees	Parkinsonia hybrid	36" Box	11	25'	Shade Tree	50	550
	Desert Museum Palo Verde	-	-	-	-	-	-
Trees	Phoenix canariensis	36" Box	2	25' HT	Non Deciduous Tree	200	200
	Canary Island Palm	-	-	-	-	-	-
Shrubs/Cactus	Plant Name	Size	Qty				
Shrubs/Cactus	Agave vilmoriniana	5 gal.	21		Large Shrub	50	1,050
	Octopus Agave	3'-4"	7		Medium Shrub	25	175
	Stenocereus thurberi	5 gal.	27		Small Shrub	10	270
	Agave parryi	5 gal.	31		Small Shrub	10	310
	Parry's Agave	5 gal.	59		Herbaceous perennial ground cover	5	295
	Hesperaloe parviflora	1 gal.	54		Perennial ground cover	5	270
	Red Hesperaloe	5 gal.	78		Small Accent	5	390
	Fouquieria splendens	1 gal.	59		Herbaceous perennial ground cover	5	295
	Ocotillo	1 gal.	54		Perennial ground cover	5	270
	Kroenleinia grusonii	1 gal.	54		Perennial ground cover	5	270
Golden Barrel Cactus	1 gal.	54		Perennial ground cover	5	270	
Delosperma cooperi	1 gal.	54		Perennial ground cover	5	270	
Ice Plant	1 gal.	54		Perennial ground cover	5	270	
Tradescantia pallida	1 gal.	54		Perennial ground cover	5	270	
Purple Heart	1 gal.	54		Perennial ground cover	5	270	
Inerts	Description	Qty					
Inerts	Decomposed Granite Screened Desert Brown 3/4"	3,420 SF.					
	Rip Rap Per Civil	30 SF.					
Mature Tree Credit in SF				225 SF	Total Credit in SF		3,530
6.5% of the site landscape							

LANDSCAPE CALCULATIONS

W. University Street Landscape 114.85 LF
 Required Trees 1 Tree Per 25 LF ($114.85/25 = 4.6$) (2) 36" Box & (3) 24" Box Trees Required
 Provided Trees (4) 36" Box = (4) 24" Box Trees
 Required Shrubs 6 Shrubs Per 25 LF ($114.85/25 = 4.6 \times 6 = 27.6$) 28 Shrubs Required
 Provided Shrubs (58) 5 gal

N. Longmore Street Landscape 123.00 LF
 Required Trees 1 Tree Per 25 LF ($123/25 = 4.9$) (2) 36" Box & (3) 24" Box Trees Required
 Provided Trees (2) 36" Box = (4) 24" Box Trees & (2) Ocotillo = (1) 24" Box Tree
 Required Shrubs 6 Shrubs Per 25 LF ($123/25 = 4.9 \times 6 = 29.4$) 30 Shrubs Required
 Provided Shrubs (80) 5 gal

W. Property Line Interior Landscape 133.40 LF
 Required Trees - Four (4) non-deciduous trees Per 100 LF
 ($133/100 = 1.33 \times 4 = 5.32$) (6) 24" Box Trees Required
 Provided Trees (3) 36" Box Trees Provided = (6) 24" Box Trees
 Required Shrubs - 20 Shrubs Per 100 LF ($133/100 = 1.33 \times 20 = 26.68$) 27 Shrubs Required
 Provided Shrubs (27) 5 gal

S. Property Line Interior Landscape 125 LF
 Required Trees - Four (4) non-deciduous trees Per 100 LF
 ($125/100 = 1.25 \times 4 = 4.96$) (5) 24" Box Trees Required
 Provided Trees (3) 36" Box Trees Provided = (6) 24" Box Trees
 Required Shrubs - 20 Shrub Per 100 LF ($125/100 = 1.25 \times 20 = 25$) (25) Shrubs Required
 Provided Shrubs (31) 5 gal

Foundation Base Landscape Area on the North Side of the Building Exterior
 Walls Visible From Public Parking or Right-of-Way with Public Entrances
 54'-2" Base Foundation LF x 15' Minimum = 782.5'33% = 253.23 SF Required
 0 SF Landscape Area Provided - 340 SF of Concrete Sidewalk Provided

Tree Requirements - minimum 1 tree per 50 linear feet
 Provided (1) 36" BOX Tree Provided 30' from Building

Public Entrance has been shaded with a Canopy. A foundation base is not required along exterior walls at overhead doors.

Landscape Area on the West Side of the Building No Public Access - Not Visible From Public Parking or Right-of-Way without Public Entrances
 91'-4" Base Foundation LF x 5' Minimum = 457.5'10% = 45.75 SF Required
 89.93 SF Plant Area Provided. 243 SF of Concrete Sidewalk Provided

Foundation Base Landscape Area on the South Side of the Building - Not Visible From Public Parking or Right-of-Way without Public Entrances
 48'-10" Base Foundation LF x 5' Minimum = 244.14'10% = 24.42 SF Required
 215.68 SF Plant Area Provided.

Foundation Base Landscape Area on the East Side of the Building - Exterior Wall Visible From Public Parking or Right-of-Way without Public Entrances
 38'-8" Base Foundation LF x 5' Minimum = 194.0'25% = 48.5 SF Required
 502.27 SF Plant Area Provided.

Parking Lot Trees
 (4) Total spaces provided (1 ADA Space) - No Parking Island

Parking Lot Trees Required
 Trees 1 shade tree and 6 shrubs shall be provided for every 8 parking spaces $4/8 = (0.5)$ (1) 24" Box Tree Required.
 Provided Trees (1) 36" Box Tree = (2) 24" Box Tree
 Required 6 shrubs shall be provided for every 8 parking spaces ($7/8 = 0.875 \times 6$)
 5.25 Shrubs Required. Provided Shrubs (6) 5 Gal

General Notes:

- DECORATIVE SCREEN WALL - CONSTRUCTION NOTE
- Provide and install (4) decorative screen wall panels, each measuring 36" wide x 72" high, as indicated on the plans.
- Decorative screen panels shall be Outdco Screen (or approved equal) and shall be surface-mounted to existing concrete. Panels shall be attached using manufacturer-recommended mounting brackets and corrosion-resistant mechanical anchors suitable for concrete installation. Anchors shall be sized and spaced per structural requirements and manufacturer guidelines to ensure stability and wind-load compliance.
- Concrete surface shall be verified to be sound and capable of supporting the installation. Contractor shall field-verify dimensions and conditions prior to fabrication.
- Contractor shall supply shop drawings for review and approval prior to fabrication. Shop drawings shall include panel layout, surface-mount attachment details, anchor specifications, base plate details (if applicable), and finish information.

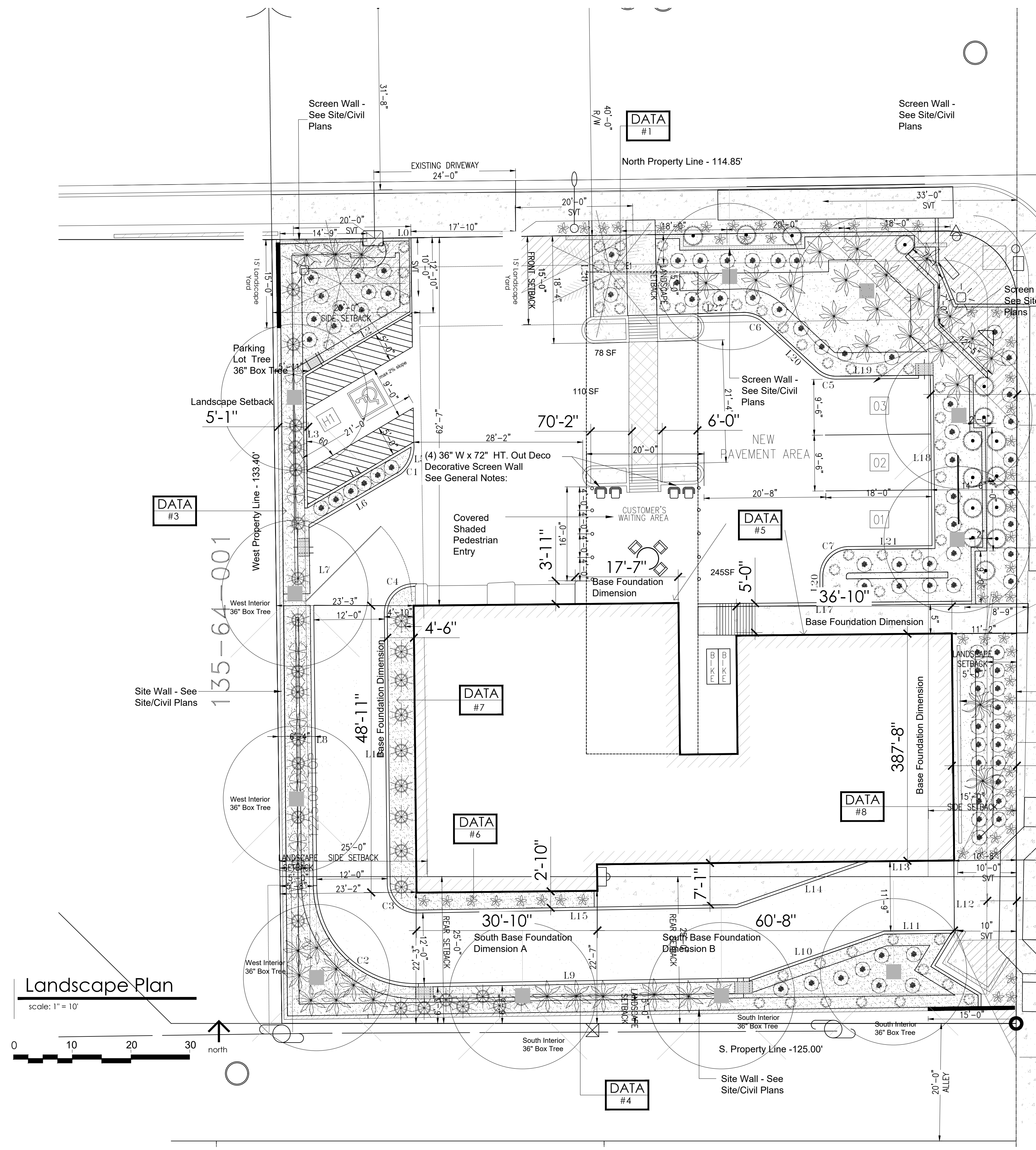

Landscape Plan
 scale: 1" = 10'

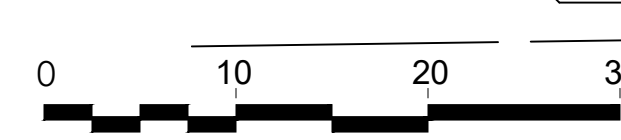

PROJECT MANAGER: _____
 DATE: _____
 REVIEW: _____
 BY: _____

Landscape Architect
 Mac Design Studio
 1525 South Higley Road Suite # 104
 Gilbert, Arizona 85296
 Contact: Steven McLeod, Principal
 steven@macdesignstudio.net
 602.345.0325

REGISTERED LANDSCAPE ARCHITECT
 74312
 RHEINHART
 ARIZONA
 EXPIRES 09/30/27

NEW TENANT IMPROVEMENT PLAN
 TRES HERMANOS LLC'S
 "SAN ANTONIO TIRE SHOP"
 1609 W. UNIVERSITY DRIVE, MESA, AZ

SECTION: 30
 TNSHP: 1N
 RANGE: 2E

JOB NO.:
 Landscape Plan
 Zoning

SHEET
 OF 1

