

BLOCK VENEER 8" X 4" X 16"
ECHELON STANDARD MASONRY
COLOR: SALT AND PEPPER

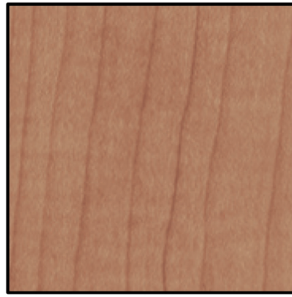

WOOD SIDING
ALPOLIC
COLOR: MPL MAPLE

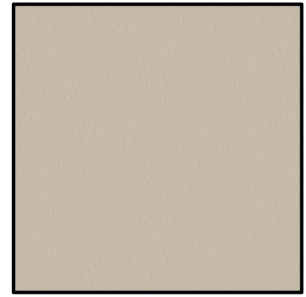

SYNTHETIC STUCCO SYSTEM
FINISH: SMOOTH SAND FINISH
COLOR: SHERWIN WILLIAMS
SW 9173 "SHIITAKE"

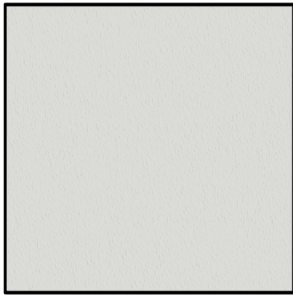

SYNTHETIC STUCCO SYSTEM
FINISH: SMOOTH SAND FINISH
COLOR: SHERWIN WILLIAMS
SW 7666 "FLEUR DE SEL"

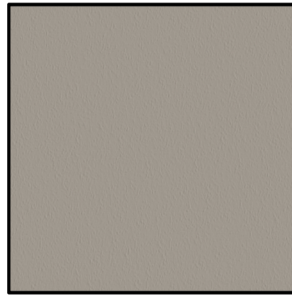

SYNTHETIC STUCCO SYSTEM
FINISH: SMOOTH SAND FINISH
COLOR: SHERWIN WILLIAMS
SW 7642 "PAVESTONE"



METAL CANOPY AND COLUMN
COLOR: SHERWIN WILLIAMS
SW 6258 "TRICORN BLACK"



HARDSCAPE
COLOR: GRAY CONCRETE
BROOM FINISH

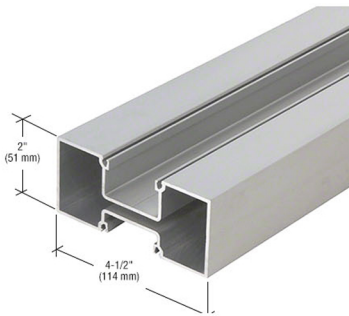

ALUMINUM STOREFRONT
MANUFACT: KAWNEER
COLOR: CLEAR ANODIZED

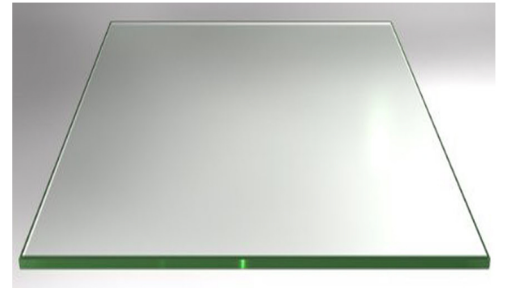

1" INSULATED GLAZING
VALUE: (U=0.29. SHGC=0.28)



TRASH CAN - TYPICAL
HINGE TOP RECEPTACLE
BELSON OUTDOOR OR EQUIVALENT
COLOR: BLACK



BENCH- TYPICAL
RECYCLED PLASTIC COUNTOURED BENCH
BELSON OUTDOOR OR EQUIVALENT
COLOR: GRAY

FINISH SCHEDULE			
MARK	MANUFACTURER	DESCRIPTION	NOTES
FINISHES			
A1	DRYVIT	SYNTHETIC STUCCO SYSTEM	SHERWIN WILLIAMS SW 7666 -"FLEUR DE SEL TEXTURE: SMOOTH SAND FINISH
A2	DRYVIT	SYNTHETIC STUCCO SYSTEM	SHERWIN WILLIAMS SW 9173-"SHIITAKE TEXTURE: SMOOTH SAND FINISH
B	WOOD SIDING	ALPOLIC	COLOR: MPL MAPLE TEXTURE: ALPOLIC
C	DRYVIT	EIFS WITH BLOCK VENEER PATTERN	MATCH ECHELON STANDARD MASONRY COLOR: SALT AND PEPPER
D	SHERWIN WILLIAMS	SW #6869 STOP	SATIN FINISH
E	NOT USED	---	---
F	NOT USED	---	---
G	SHERWIN WILLIAMS	SW #7666 FLEUR DE SEL	SATIN FINISH
H	NOT USED	---	---
J	NOT USED	---	---
METALS			
A	EXCEPTIONAL METALS/ DURO-LAST	TWO-PIECE SNAP-ON METAL COPING REGAL WHITE/ DURO-LAST	FOR USE WITH DURO-LAST ROOFING SYSTEM DETAIL FA3110
B	EXCEPTIONAL METALS/ DURO-LAST	TWO-PIECE SNAP-ON METAL COPING LIGHT STONE/ DURO-LAST	FOR USE WITH DURO-LAST ROOFING SYSTEM DETAIL FA3110
C	PRE-FABRICTED CANOPY/BAND	PRODUCT CODE: 9940-30198R PRODUCT NAME: FC SD RAL 3000 FLAME RED	---

A1
A1
TEXTURE WISE

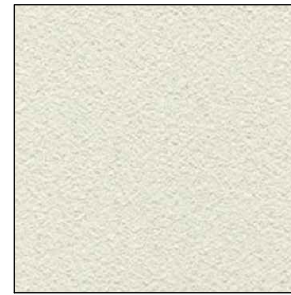

A1
PAINT COLOR

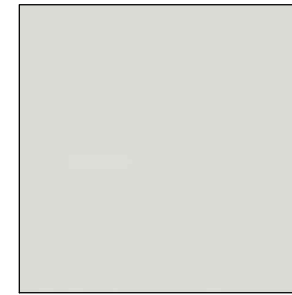

A2
PAINT COLOR

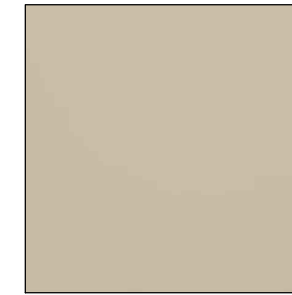

B

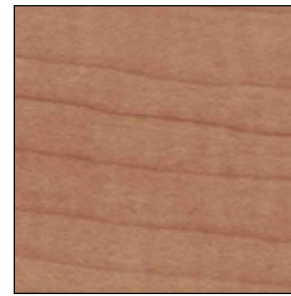

C

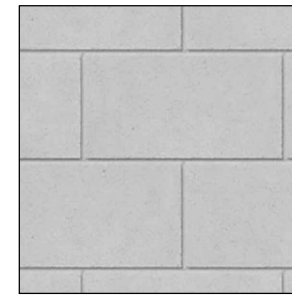

D

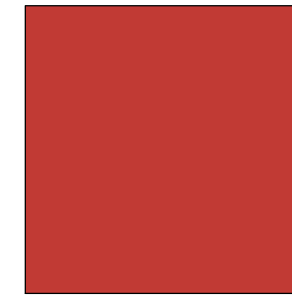

G

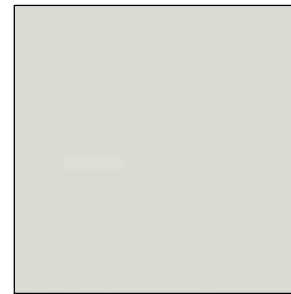

A

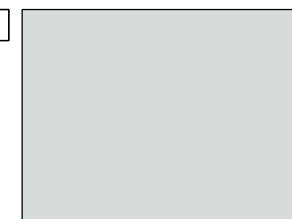

B



C



red
architecture + planning
589 w nationwide blvd
suite b
columbus, ohio 43215
tel: 614.487.8770
fax: 614.487.8777

COPYRIGHT 2023. ALL DRAWINGS AND SPECIFICATIONS SHALL REMAIN THE PROPERTY OF RED ARCHITECTURE + PLANNING LLC AND MAY NOT BE USED, DUPLICATED OR ALTERED WITHOUT THE WRITTEN CONSENT OF THE ARCHITECT.

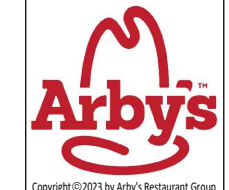

ARBY'S RESTAURANT
NEW RESTAURANT DEVELOPMENT
ELLSWORTH MESA, AZ
FOR
KBP BRANDS
10950 GRANDVIEW DR #300, OVERLAND PARK, KS 66210

PROJECT NUMBER:
ARF270

ISSUE	DATE
SD	12.22.2023
SD UPDATE	02.08.2023

