

CCC MESA CHILDREN'S BUILDING

933 N. LINDSAY ROAD
MESA, AZ 85213

CENTRAL CHRISTIAN
933 N. LINDSAY ROAD MESA, AZ 85213

(480) 924-4946 P
(480) 924-4990 F



TODD + ASSOCIATES
CRITICAL THINKING / CREATIVE DESIGN

ARCHITECTURE, PLANNING,
LANDSCAPE ARCHITECTURE.

4019 N. 44TH ST. / PHOENIX, AZ 85018
602 - 952 - 8280 / TODDASSOC.COM

Copyright 2021 Todd + Associates, Inc.

09/28/23
SCIP SUBMITTAL

Proj Mgr. -
Dwn By: Author

Rev. Date: Description:

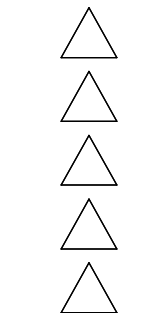

"PROMPT PAYMENT NOTICE"
The Owner is familiar with the "Arizona Prompt Payment Law" and payments will comply with the 30 day billing cycle.

OVERALL SITE PLAN

A1.0

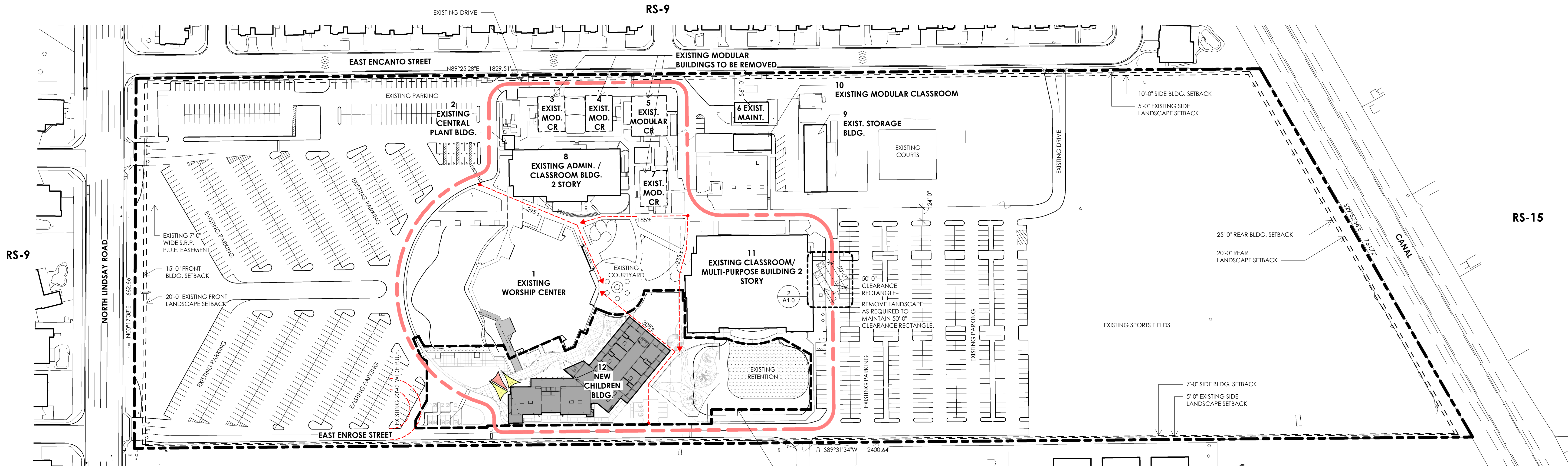

RS-9

RS-9

RS-15

RS-9 PROPOSED SITE DEVELOPMENT AREA: ± 2.51 AC - SEE SHEET A1.2 FOR ENLARGED SITE PLAN OF THIS AREA. (SEE CIVIL SHEETS C3 & C4 FOR EXTENT OF PROPOSED DEMOLITION/REMOVAL OF EXISTING)

1 OVERALL SITE PLAN
1" = 80'-0"

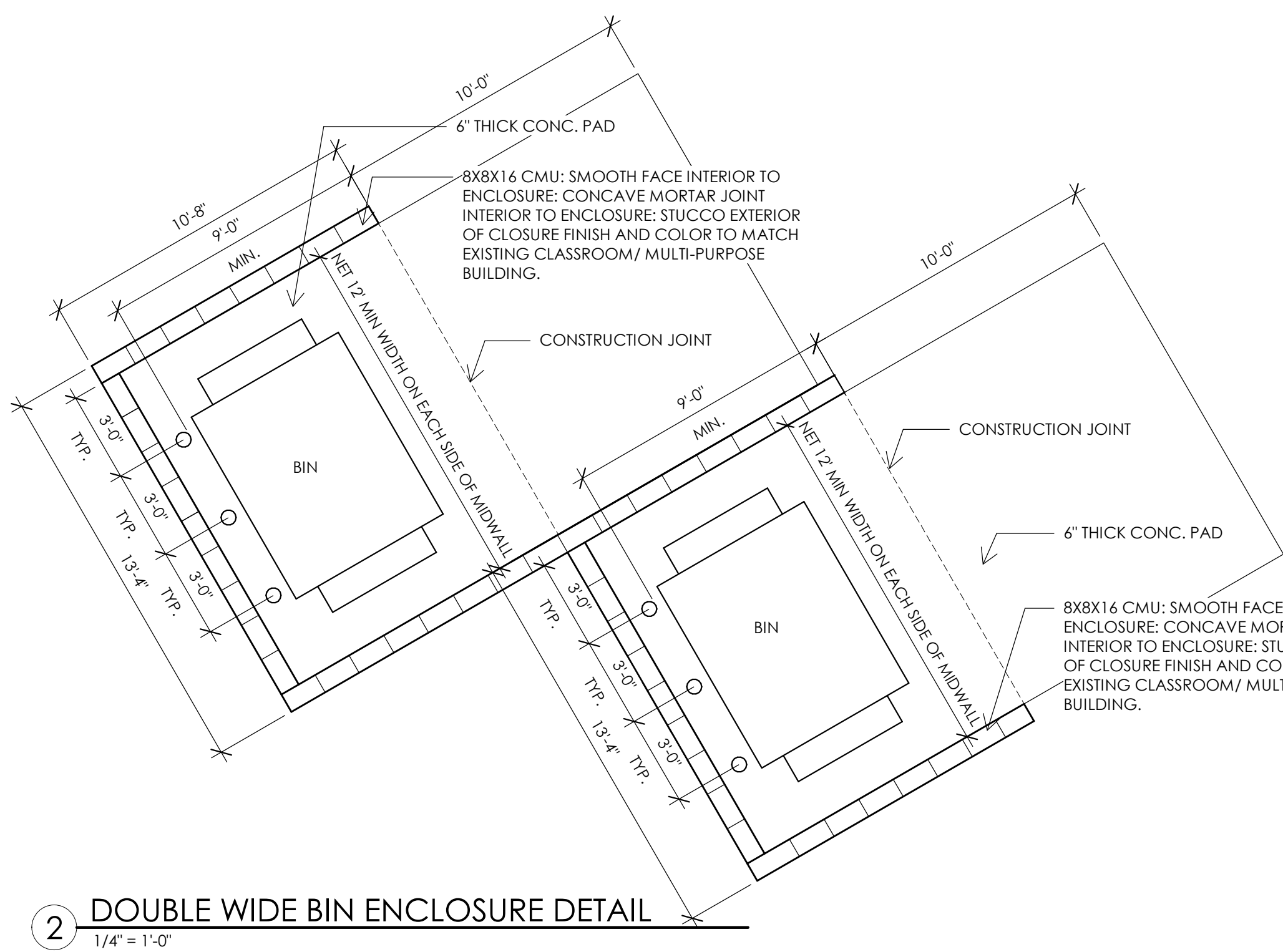

2 DOUBLE WIDE BIN ENCLOSURE DETAIL
1/4" = 1'-0"

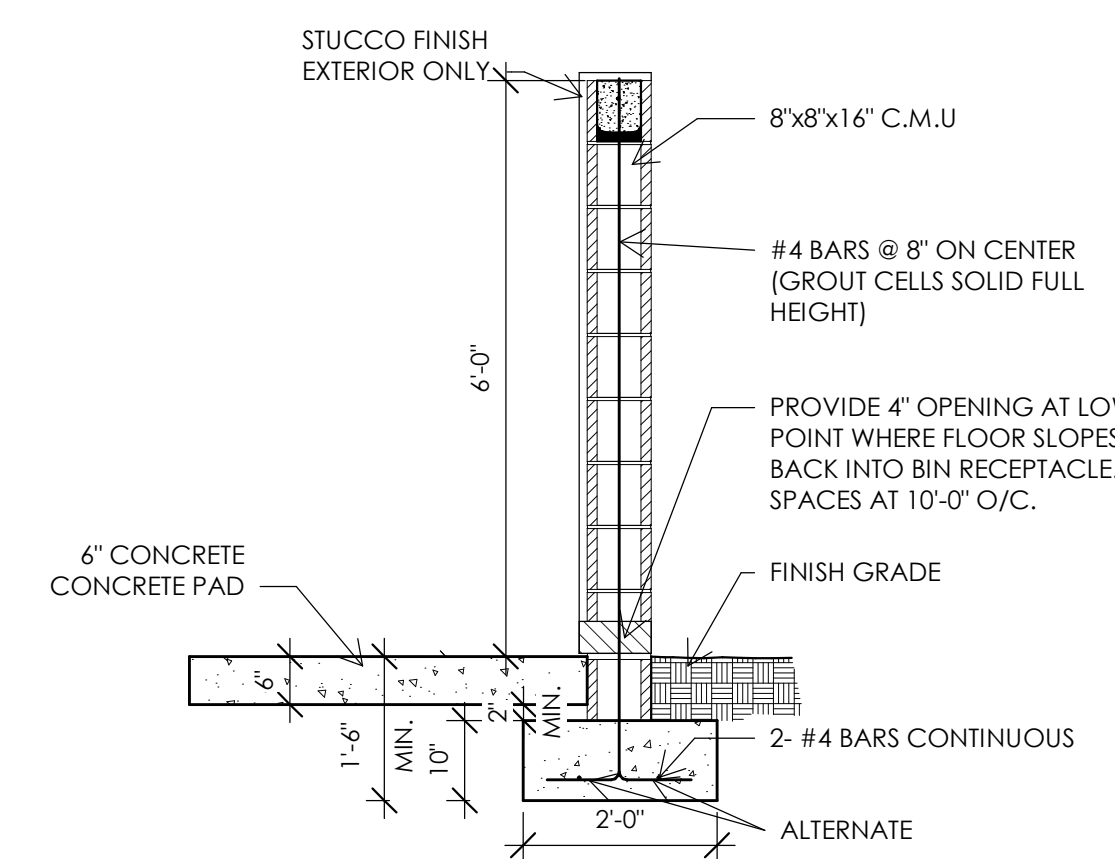

3 6 FOOT MASONRY SCREEN WALL
1/2" = 1'-0"

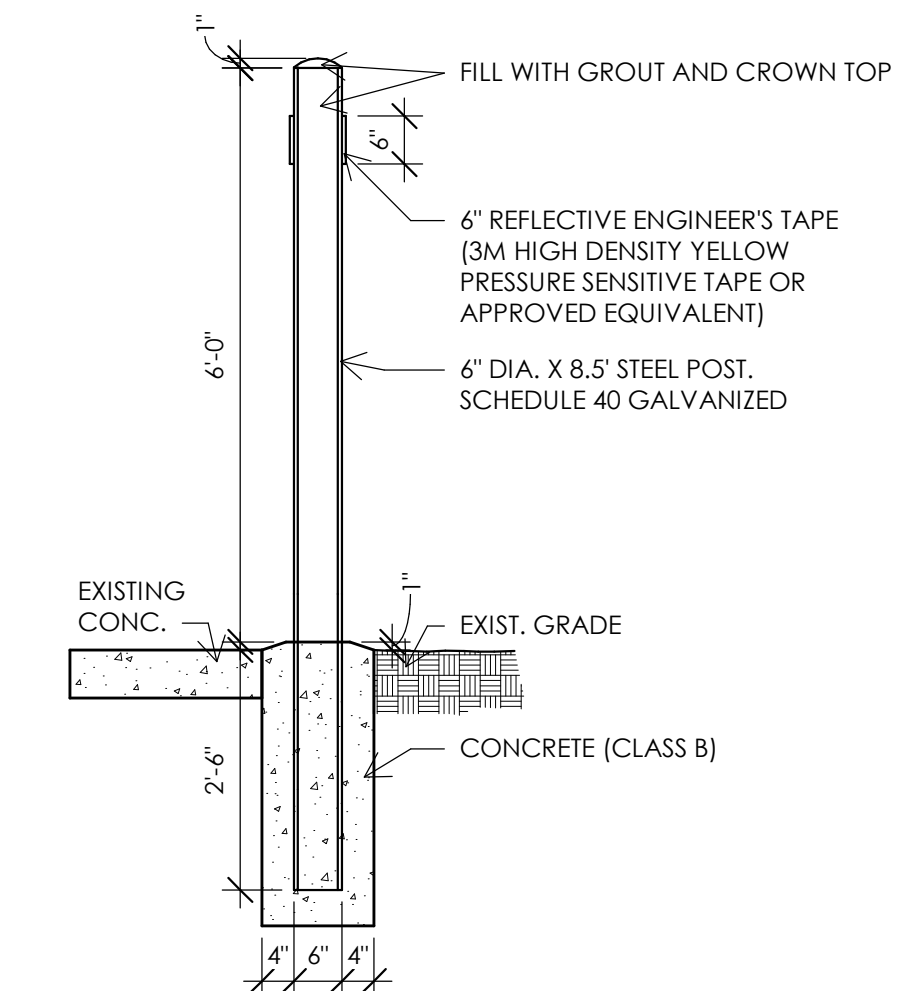

4 SAFETY POST
1/2" = 1'-0"

PROJECT DATA

PROJECT NAME & ADDRESS:
CENTRAL CHRISTIAN CHURCH - CHILDREN'S BUILDING
933 N. LINDSAY ROAD
MESA, AZ 85213

PROJECT DESCRIPTION:
NEW CONSTRUCTION OF 24,470 S.F. CHILDREN'S CENTER ON ± 35 GROSS ACRES. THE BUILDINGS FOR THIS DEVELOPMENT CONSIST OF: NEW 1-STORY CHILDREN'S CLASSROOM BUILDING.

GENERAL BUILDING CODE ANALYSIS:
PROPOSED USE: ASSEMBLY (PLACE OF WORSHIP)
OCCUPANCY: A-3 @ CHILDREN'S BLDG.
CONSTRUCTION TYPE: III-B W/ NFPA 13 @ CHILDREN'S BLDG.)

AUTHORITIES HAVING JURISDICTION & ASSOCIATED CODES AND REGULATIONS:
2018 INTERNATIONAL BUILDING CODE (IBC)
2018 INTERNATIONAL MECHANICAL CODE (IMC)
2018 INTERNATIONAL PLUMBING CODE (IPC)
2017 NATIONAL ELECTRIC CODE (NEC)
2018 INTERNATIONAL FUEL GAS CODE
2018 INTERNATIONAL ENERGY CONSERVATION CODE
2018 INTERNATIONAL FIRE CODE (IFC)

ICC A117.1-2009 - ACCESSIBLE AND USABLE BUILDINGS AND FACILITIES
2010 ADA STANDARDS FOR ACCESSIBLE DESIGN

GENERAL SITE DATA:
SITE AREA
GROSS ± 35 AC (±1,472,622 S.F.)
NET ± 33 AC (±1,437,480 S.F.)

ZONING:
EXISTING RS-9
PROPOSED RS-9

BUILDING HEIGHT:
ALLOWED 30 FEET
PROVIDED 30 FEET

FIRE SPRINKLER SYSTEM:
BUILDING 12 (CHILDREN'S BLDG.) NFPA 13

BUILDING SETBACKS:
FRONT (WEST) 15' REQUIRED, 25' PROVIDED
SIDE (NORTH) 10' REQUIRED, 15' PROVIDED
SIDE (SOUTH) 7' REQUIRED, 10' PROVIDED
REAR (EAST, CANAL) 15' REQUIRED, 20' PROVIDED

LANDSCAPE SETBACKS:
FRONT (WEST) 20' REQUIRED, 20' PROVIDED
SIDE (NORTH) 20' REQUIRED, 5' PROVIDED
SIDE (SOUTH) 20' REQUIRED, 5' PROVIDED
REAR (EAST, CANAL) 20' REQUIRED, 20' PROVIDED

BUILDING AREA:
EXISTING BUILDING AREA:
BUILDING 1 (WORSHIP CENTER) ± 33,792 S.F.
BUILDING 2 (CENTRAL PLANT BUILDING) ± 2,388 S.F.
BUILDING 3 (MODULAR CLASSROOM (CR)) ± 2,400 S.F.
BUILDING 4 (MODULAR CLASSROOM (CR)) ± 2,400 S.F.
BUILDING 5 (MODULAR CLASSROOM (CR)) ± 4,200 S.F.
BUILDING 6 (MAINTENANCE BUILDING) ± 2,140 S.F.
BUILDING 7 (MODULAR CLASSROOM (CR)) ± 2,880 S.F.
BUILDING 8 (ADMIN./CLASSROOM BLDG.) ± 34,081 S.F.
BUILDING 9 (STORAGE BLDG.) ± 4,800 S.F.
BUILDING 10 (MODULAR CLASSROOM (CR)) ± 2,072 S.F.
BUILDING 11 (CLASSROOM/MULTI-PURPOSE) ± 58,635 S.F.
TOTAL EXISTING BUILDINGS AREA ± 147,658 S.F.

PARKING STANDARDS:
PARKING STALL (90°) 9'-0" x 18'-0"
PARKING STALL (45°) 9'-0" x 19'-10"
PARKING AISLE 24'-0"

REQUIRED PARKING:
1 SPACE PER 75 S.F. USED FOR PUBLIC ASSEMBLY

WORSHIP CENTER - BUILDING 1 451 P.S.
MULTI-PURPOSE SPACE AND FOYER - BUILDING 11 181 P.S.
CHILDREN'S BUILDING 9,816 S.F. ± 75 131 P.S.
TOTAL REQUIRED PARKING 763 P.S.

PROVIDED PARKING:
EXISTING PARKING ± 1,150 P.S. (25 ACCESSIBLE)
ADJUSTED PARKING (-47 P.S.) ± 1,103 P.S. (24 ACCESSIBLE)

BUILDING AREA (CONT.)
EXISTING BUILDINGS TO BE REMOVED AREA
BUILDING 3 (MODULAR CLASSROOM (CR)) ± 2,400 S.F.
BUILDING 4 (MODULAR CLASSROOM (CR)) ± 2,400 S.F.
BUILDING 5 (MODULAR CLASSROOM (CR)) ± 4,200 S.F.
BUILDING 7 (MODULAR CLASSROOM (CR)) ± 2,880 S.F.
TOTAL AREA TO BE REMOVED ± 11,880 S.F.

PROPOSED BUILDING AREA
1ST FLOOR ± 19,092 S.F.
1ST FLOOR EXTERIOR CIRCULATION ± 5,378 S.F.
TOTAL ± 24,470 S.F.

TOTAL ADJUSTED BUILDING AREA
147,658 S.F. - 11,880 S.F. = 135,778 S.F.
135,778 S.F. + 24,470 S.F. = 160,248 S.F.

BUILDING TYPE
BUILDING 1 (WORSHIP CENTER) ± 33,792 S.F.
BUILDING 2 (CENTRAL PLANT BUILDING) ± 2,388 S.F.
BUILDING 3 (MODULAR CLASSROOM (CR)) ± 2,400 S.F.
BUILDING 4 (MODULAR CLASSROOM (CR)) ± 2,400 S.F.
BUILDING 5 (MODULAR CLASSROOM (CR)) ± 4,200 S.F.
BUILDING 6 (MAINTENANCE BUILDING) ± 2,140 S.F.
BUILDING 7 (MODULAR CLASSROOM (CR)) ± 2,880 S.F.
BUILDING 8 (ADMIN./CLASSROOM BLDG.) ± 34,081 S.F.
BUILDING 9 (STORAGE BLDG.) ± 4,800 S.F.
BUILDING 10 (MODULAR CLASSROOM (CR)) ± 2,072 S.F.
BUILDING 11 (CLASSROOM/MULTI-PURPOSE) ± 58,635 S.F.
BUILDING 12 (CHILDREN'S BUILDING) ± 24,470 S.F.
TOTAL ± 123,155 S.F.

LOT COVERAGE:
ALLOWED: 45%
PROVIDED: (123,155 S.F. / 1,437,480 S.F.) = 8.6%
NOTE: LOT COVERAGE = BUILDING FOOTPRINT

GENERAL NOTES

- REFERENCE HARDSCAPE PLANS FOR ADDITIONAL INFORMATION.
- REFERENCE CIVIL PLANS FOR ALL SITE ELEVATIONS, GRADES AND RELATED INFORMATION.

SYMBOLS

- SEE DRAWING A0.1 FOR ADDITIONAL SYMBOLS
- DASHED LINE TYPE INDICATES APPROXIMATE EXTENTS OF LIMITS OF CONSTRUCTION
- SOLID LINE TYPE INDICATES ITEMS TO REMAIN
- DASHED LINE TYPE INDICATES ITEMS TO BE REMOVED
- INDICATES EXISTING FIRE LANE
- INDICATES FIRE TRAVEL DISTANCE

KEYMAP

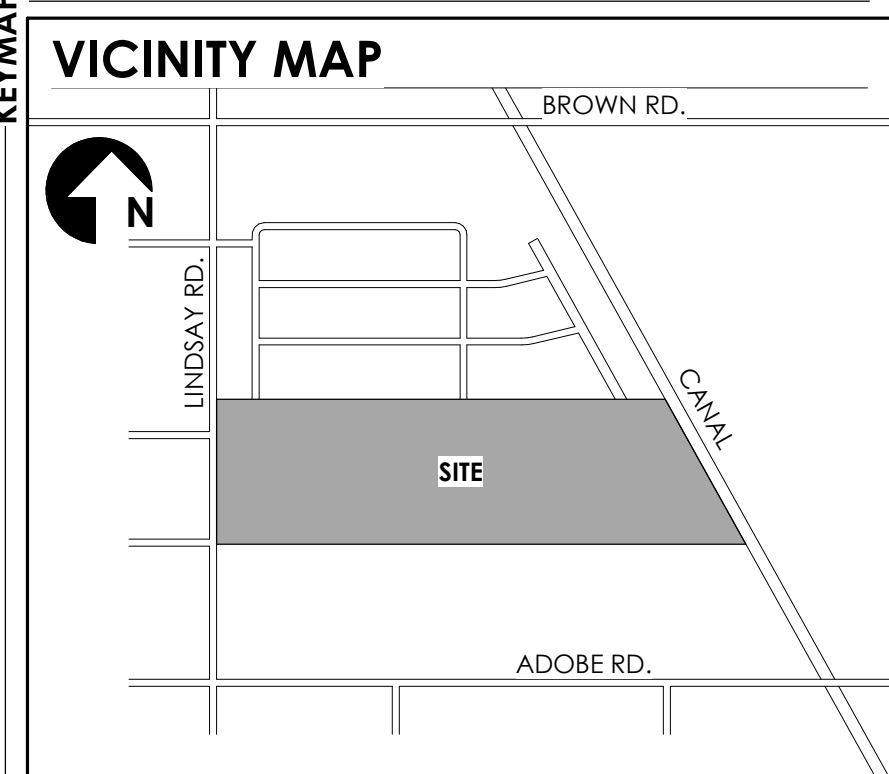

SYMBOLS

- INDICATES APPROXIMATE EXTENTS OF LIMITS OF CONSTRUCTION
- SOLID LINE TYPE INDICATES ITEMS TO REMAIN
- DASHED LINE TYPE INDICATES ITEMS TO BE REMOVED
- INDICATES EXISTING FIRE LANE
- INDICATES FIRE TRAVEL DISTANCE

CCC MESA CHILDREN'S BUILDING

933 N. LINDSAY ROAD
MESA, AZ 85213

CLIENT **CENTRAL CHRISTIAN**
933 N. LINDSAY ROAD MESA, AZ 85213

(480) 924-4946 P
(480) 924-4990 F



CONTACT **TODD + ASSOCIATES**
CRITICAL THINKING / CREATIVE DESIGN

ARCHITECTURE, PLANNING,
LANDSCAPE ARCHITECTURE.

4019 N. 44TH ST. / PHOENIX, AZ 85018
602-952-8280 / TODDASSOC.COM
Copyright 2021 Todd + Associates, Inc.

PHASE 09/11/23
SCIP SUBMITTAL

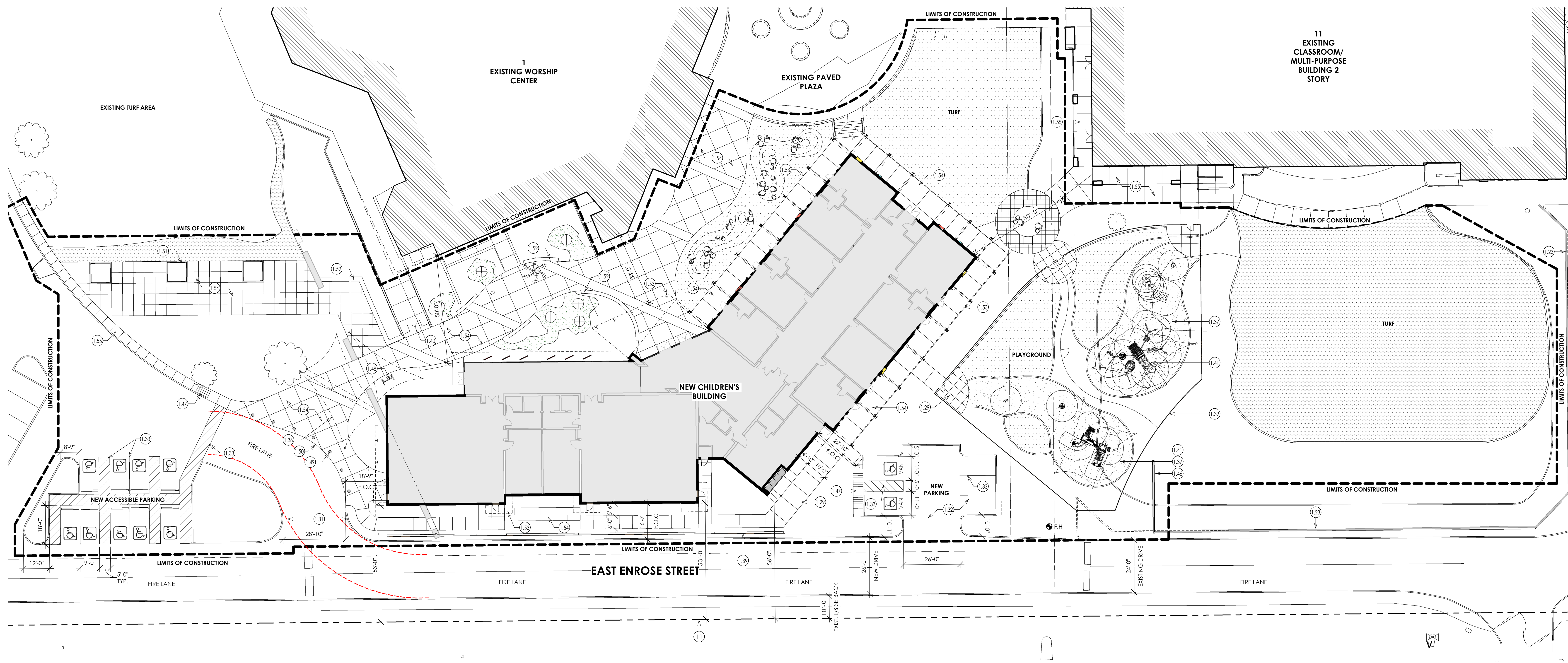

ENLARGED SITE PLAN

1" = 20'-0"



PROJECT DATA

PROJECT NAME & ADDRESS:
CENTRAL CHRISTIAN CHURCH - CHILDREN'S BUILDING
933 N. LINDSAY ROAD
MESA, AZ 85213

PROJECT DESCRIPTION:
NEW CONSTRUCTION OF 24,470 S.F. CHILDREN'S CENTER ON ± 35 GROSS ACRES. THE BUILDINGS FOR THIS DEVELOPMENT CONSIST OF: NEW 1-STORY CHILDREN'S CLASSROOM BUILDING.

GENERAL BUILDING CODE ANALYSIS:
PROPOSED USE: ASSEMBLY (PLACE OF WORSHIP)
OCCUPANCY: A-3 @ CHILDREN'S BLDG.
CONSTRUCTION TYPE: III-B W/ NFPA 13 @ CHILDREN'S BLDG.)

AUTHORITIES HAVING JURISDICTION & ASSOCIATED CODES AND REGULATIONS:
2018 INTERNATIONAL BUILDING CODE (IBC)
2018 INTERNATIONAL MECHANICAL CODE (IMC)
2018 INTERNATIONAL PLUMBING CODE (IPC)
2017 NATIONAL ELECTRIC CODE (NEC)
2018 INTERNATIONAL FUEL GAS CODE
2018 INTERNATIONAL ENERGY CONSERVATION CODE
2018 INTERNATIONAL FIRE CODE (IFC)

ICC A117.1-2009 - ACCESSIBLE AND USABLE BUILDINGS AND FACILITIES
2010 ADA STANDARDS FOR ACCESSIBLE DESIGN

GENERAL SITE DATA:
SITE AREA
GROSS ± 35 AC [±1,472,622 S.F.]
NET ± 33 AC [±1,437,480 S.F.]

ZONING:
EXISTING RS-9
PROPOSED RS-9
BUILDING HEIGHT:
ALLOWED 30 FEET
PROVIDED 30 FEET
FIRE SPRINKLER SYSTEM:
BUILDING 12 (CHILDREN'S BLDG.) NFPA 13

BUILDING SETBACKS: REQUIRED: PROVIDED:
FRONT (WEST) 15' 25'
SIDE (NORTH) 10' 15'
SIDE (SOUTH) 7' 10'
REAR (EAST, CANAL) 15' 20'
LANDSCAPE SETBACKS: REQUIRED: PROVIDED:
FRONT (WEST) 20' 20'
SIDE (NORTH) 20' 5'
SIDE (SOUTH) 20' 5'
REAR (EAST, CANAL) 20' 20'

BUILDING AREA:
EXISTING BUILDING AREA:
BUILDING 1 (WORSHIP CENTER) ± 33,792 S.F.
BUILDING 2 (CENTRAL PLANT BUILDING) ± 238 S.F.
BUILDING 3 (MODULAR CLASSROOM (CR)) ± 2,400 S.F.
BUILDING 4 (MODULAR CLASSROOM (CR)) ± 2,400 S.F.
BUILDING 5 (MODULAR CLASSROOM (CR)) ± 4,200 S.F.
BUILDING 6 (MAINTENANCE BUILDING) ± 2,160 S.F.
BUILDING 7 (MODULAR CLASSROOM (CR)) ± 2,880 S.F.
BUILDING 8 (ADMIN./CLASSROOM BLDG.) ± 34,081 S.F.
BUILDING 9 (STORAGE BLDG.) ± 4,800 S.F.
BUILDING 10 (MODULAR CLASSROOM (CR)) ± 2,072 S.F.
BUILDING 11 (CLASSROOM/MULTI-PURPOSE) ± 58,635 S.F.
TOTAL EXISTING BUILDINGS AREA ± 147,658 S.F.

PARKING STANDARDS:
PARKING STALL (90°) 9'-0" x 18'-0"
PARKING STALL (45°) 9'-0" x 19'-10"
PARKING AISLE 24'-0"
REQUIRED PARKING:
1 SPACE PER 75 S.F. USED FOR PUBLIC ASSEMBLY
WORSHIP CENTER - BUILDING 1 451 P.S.
MULTI-PURPOSE SPACE AND FOYER - BUILDING 11 181 P.S.
CHILDREN'S BUILDING 9,816 S.F. ± 75 131 P.S.
TOTAL REQUIRED PARKING 763 P.S.

PROVIDED PARKING:
EXISTING PARKING ± 1,150 P.S. (25 ACCESSIBLE)
ADJUSTED PARKING (-47 P.S.) ± 1,103 P.S. (24 ACCESSIBLE)

BUILDING AREA (CONT.)
EXISTING BUILDINGS TO BE REMOVED AREA:
BUILDING 3 (MODULAR CLASSROOM (CR)) ± 2,400 S.F.
BUILDING 4 (MODULAR CLASSROOM (CR)) ± 2,400 S.F.
BUILDING 5 (MODULAR CLASSROOM (CR)) ± 4,200 S.F.
BUILDING 7 (MODULAR CLASSROOM (CR)) ± 2,880 S.F.
TOTAL AREA TO BE REMOVED ± 11,880 S.F.
PROPOSED BUILDING AREA:
1ST FLOOR ± 19,092 S.F.
1ST FLOOR EXTERIOR CIRCULATION ± 5,378 S.F.
TOTAL ± 24,470 S.F.

BUILDING TYPE:
BUILDING 1 (WORSHIP CENTER) ± 33,792 S.F.
BUILDING 2 (CENTRAL PLANT BUILDING) ± 238 S.F.
BUILDING 6 (MAINTENANCE BUILDING) ± 2,160 S.F.
BUILDING 8 (ADMIN./CLASSROOM BLDG.) ± 34,081 S.F.
BUILDING 9 (STORAGE BLDG.) ± 4,800 S.F.
BUILDING 10 (MODULAR CLASSROOM (CR)) ± 2,072 S.F.
BUILDING 11 (CLASSROOM/MULTI-PURPOSE) ± 58,635 S.F.
BUILDING 12 (CHILDREN'S BUILDING) ± 24,470 S.F.
TOTAL ± 123,155 S.F.

LOT COVERAGE:
ALLOWED: 45%
PROVIDED: (123,155 S.F. / 1,437,480 S.F.) = 8.6%
*NOTE: LOT COVERAGE = BUILDING FOOTPRINT

KEYNOTES
1.1 PROPERTY LINE
1.23 EXISTING SITE/RETAINING WALL
1.29 NEW CONC. WALKWAY
1.31 NEW CURB
1.32 NEW PAVED DRIVE/PAVING
1.33 NEW PAINT STRIPING
1.36 NEW CANOPY
1.37 NEW TURF AREA
1.39 NEW FENCE
1.40 NEW GATE
1.41 CHILDREN'S PLAYGROUND EQUIPMENT
1.46 NEW RETAINING WALL
1.47 ACCESSIBLE RAMP
1.48 BIKE PARKING (3)
1.49 BOLLARDS
1.50 CONCRETE WALK FLUSH WITH ADJACENT DRIVE
1.51 NEW RAISED PLANTERS (SEE LANDSCAPE)
1.52 NEW SEAT WALL (SEE LANDSCAPE)
1.53 NEW BUILDING CANOPY
1.54 NEW SIDEWALK PAVING
1.55 EXISTING SIDEWALK PAVING

GENERAL NOTES
1. REFERENCE LANDSCAPE/HARDSCAPE PLANS FOR ADDITIONAL INFORMATION.
2. REFERENCE CIVIL PLANS FOR ALL SITE ELEVATIONS, GRADES AND RELATED INFORMATION.

SYMBOLS
SEE DRAWING AD.1 FOR ADDITIONAL SYMBOLS
--- INDICATES THE APPROXIMATE EXTENTS OF LIMITS OF CONSTRUCTION
--- SOLID LINE TYPE INDICATES ITEMS TO REMAIN
--- DASHED LINE TYPE INDICATES ITEMS TO BE REMOVED
● FIRE HYDRANT LOCATION
--- 36" ID 50' OD (N.T.S.)

KEYMAP

Proj Mgr. -
Dwn By: Author
Rev. Date: Description:



"PROMPT PAYMENT NOTICE"
The Owner is familiar with the "Arizona Prompt Payment Law" and payments will comply with the 30 day billing cycle.

ENLARGED SITE PLAN

A1.2

CCC MESA CHILDREN'S BUILDING

933 N. LINDSAY ROAD
MESA, AZ 85213

CENTRAL CHRISTIAN
933 N. LINDSAY ROAD MESA, AZ 85213

(480) 924-4946 P
(480) 924-4990 F

SEAL



TODD + ASSOCIATES
CRITICAL THINKING / CREATIVE DESIGN

ARCHITECTURE, PLANNING,
LANDSCAPE ARCHITECTURE.

4019 N. 44TH ST. / PHOENIX, AZ 85018
602-952-8280 / TODDASSOC.COM
Copyright 2021 Todd & Associates, Inc.

09/11/23
SCIP SUBMITTAL

DATA

PHASE

CONTACT

CLIENT

PROJECT

KEYNOTES

GENERAL NOTES

SYMBOLS

KEYMAP

- COORDINATE SIDEWALK LOCATIONS WITH SITE PLAN AND CIVIL DRAWINGS
- REFER TO UNIT PLANS FOR ALL DIMENSIONS AND NOTES. REFER TO DRAWINGS A6.1 SERIES
- REFER TO UNIT PLANS FOR ALL UNIT INTERIOR WALL / PARTITION TYPES
- REFER TO DRAWINGS A0.4 SERIES FOR FIRE RATINGS AND CODE INFORMATION
- COORDINATE WITH STRUCTURAL DRAWINGS FOR FOUNDATION AND FRAMING
- DIMENSIONS ARE TO FACE OF FRAMING UNLESS NOTED OTHERWISE
- EDGE OF SLAB ALIGN WITH EXTERIOR SHEATHING. SEE DETAIL 17/A10.1
- PROVIDE WATERPROOF CEILING BOARD AT EXTERIOR CEILINGS AND ROOF OVERHANG EAVES
- SEE INTERIOR DESIGN DRAWINGS FOR INTERIOR FINISHES
- COORDINATE WITH ELECTRICAL / MECHANICAL AND INTERIOR DESIGN DRAWINGS FOR TYPE AND LOCATION OF FIXTURE
- REFER TO SITE PLAN FOR FDC LOCATION
- REFER TO DRAWINGS A4.1 SERIES FOR BUILDING ELEVATIONS AND EXTERIOR FINISHES

SEE DRAWING A0.1 FOR ADDITIONAL SYMBOLS

- ROOM NAME** ← ROOM NAME OR UNIT TYPE - FOR UNIT PLANS REFER TO A6.1 SERIES
- 10001** ← ROOM NUMBER
- 100** ← BUILDING FLOOR
- 1000** ← BUILDING NUMBER
- WALL / PARTITION TYPE** REFER TO DRAWINGS A9.1 SERIES
- ASSEMBLY TYPE INDICATOR** REFER TO DRAWINGS A9.2 AND A9.3 SERIES
- 101** DOOR TYPE. REFER TO DOOR SCHEDULE A8.1 SERIES
- 10** WINDOW TYPE. REFER TO WINDOW SCHEDULE A8.2 SERIES
- 11** STOREFRONT TYPE. REFER TO DRAWING A8.2.1
- SLOPE** ← SLAB/FLOOR SLOPE - 1/8"/FT MIN 5% MAX / 2% MAX. CROSS SLOPE
- CG** ← CORNER GUARD. SEE DETAIL X/AXX.X

Proj Mgr. -
Dwn By: Author

Rev. Date: Description:

- △
- △
- △
- △
- △

"PROMPT PAYMENT NOTICE"
The Owner is familiar with the "Arizona Prompt Payment Law" and payments will comply with the 30 day billing cycle.

FLOOR PLAN

A2.1.1

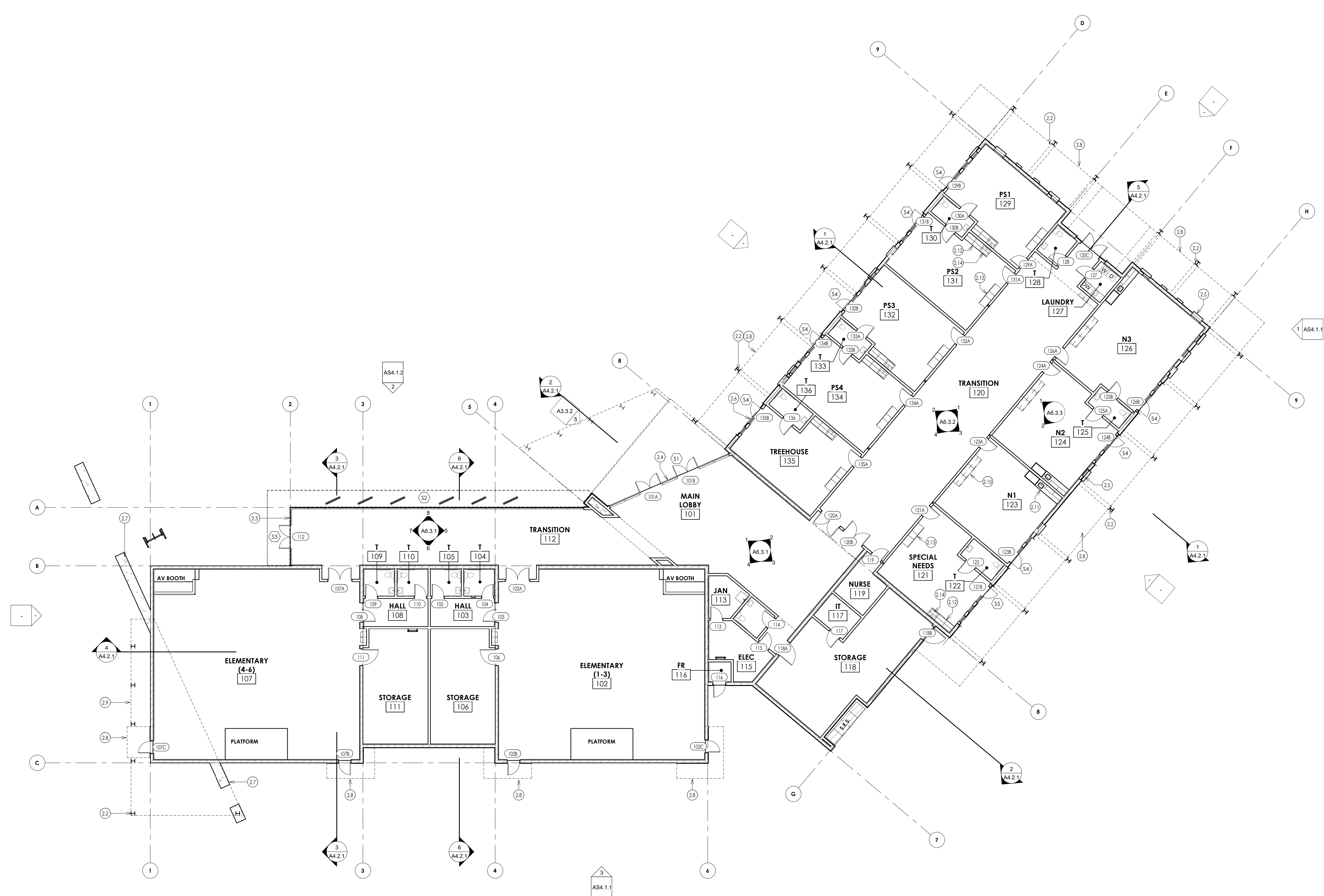

1 FLOOR PLAN - KEYNOTES & CALLOUTS
3/32" = 1'-0"