

Site - 63,019 SF/1.45 acres

30 units IRC Townhome provisions 13R Fire Supression

30 units * 550 SF = 16,500 SF

Total Building Coverage = 16,500 SF
Total Impervious Surface = 42,660 SF

16,500 SF/63,019 SF = 27% Building Coverage

42,660/63,019 SF = 68% Total Lot Coverage

Non paved (pervious) surface - per Grading and Drainage

OPEN SPACE REQUIRED
PRIVATE: 100 SF / 2BD
TOTAL: 150SF / DU

OPEN SPACE PROVIDED
PRIVATE: 30 DU * 120SF = 3,600 SF
COMMON: 3,549
TOTAL: 7,149 SF
7,149/30 = 238 / DU

Parking required 30 * 2.1 = 63
Parking provided 30 2-car (22L x 20W) garages = 60
Visitor = 14
Total Parking Provided = 74

Bicycle Parking
Required 74/10 = 7.4
Provided 5

TRASH CALCULATIONS:
30 units @ .5 cu yd per week = 15 cu yd per week
1 pick ups per week - 16 cu yds

FRONT YARD
PAVED: 730 SF
TOTAL: 4,003 SF
PAVED PERCENTAGE = 19%

DEFERRED SUBMITTALS
Fire Sprinklers

NOTE
REAL TIME CAMERAS TO BE INSTALLED AT ENTRY GATES

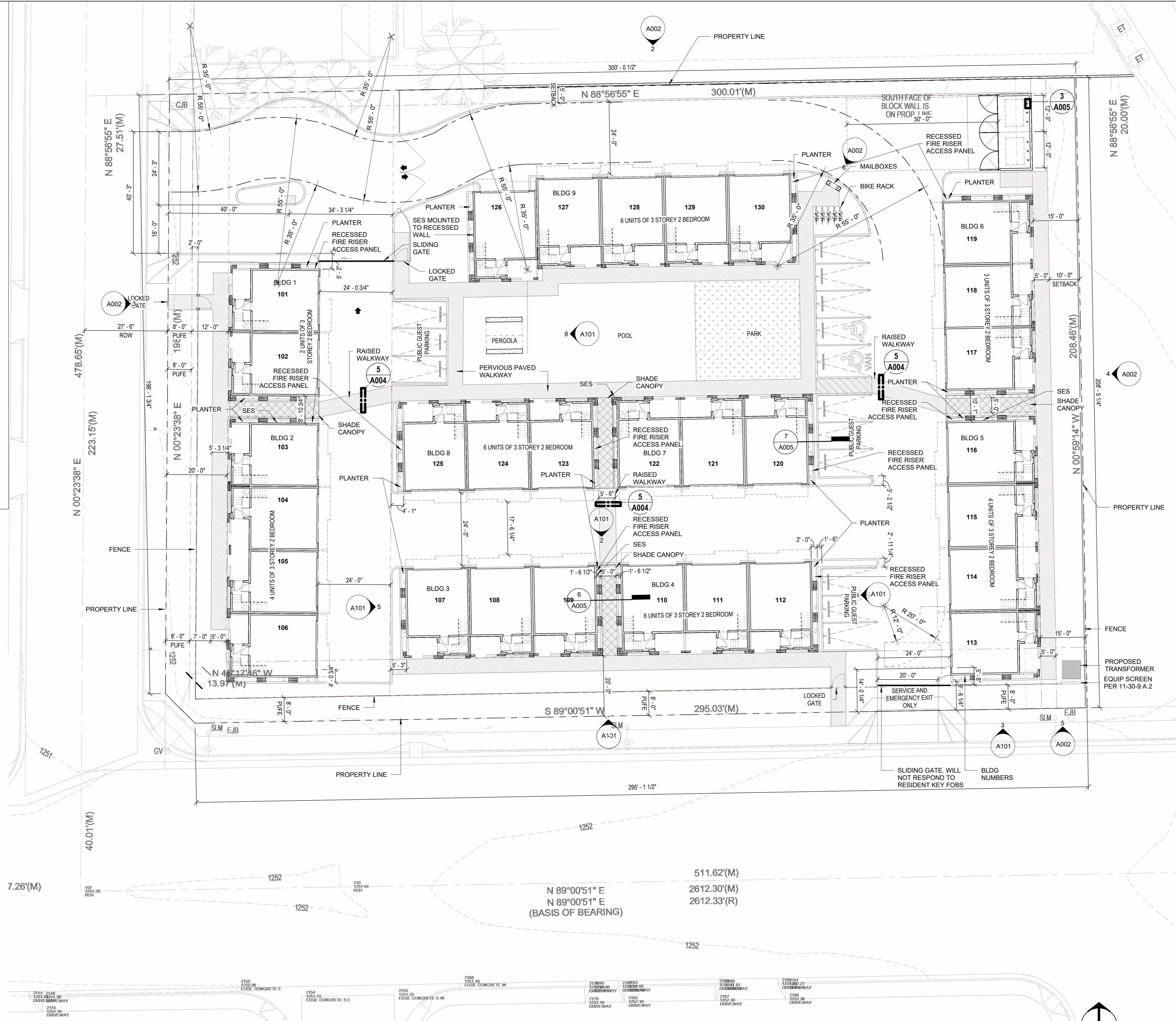

- RESIDENCE
- PRIVATE YARD
- DRIVE AILE
- WALK WAY
- PARK
- GATED ACCESS

PRELIMINARY
NOT FOR
CONSTRUCTION

no.	date	description

TANGERINE

421 N HALL
MESA, AZ 85208

PROJECT NO: 22039
DATE: 04/15/2024



atmosphere architects
114 w main st.
mesa, az 85201

contact: Tim Boyle
email: tim@atmosarch.com
tel: 917-526-0323

COPYRIGHT 2022 BY ATMOSPHERE ARCHITECTS PRINTED: 4/16/2024 4:27:08 PM

1 SITE PLAN
1/16" = 1'-0"



SITE PLAN
A001

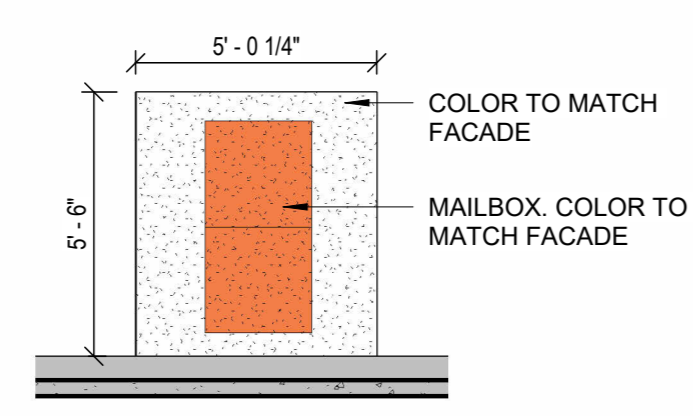

6 MAIL KIOSK
1/4" = 1'-0"

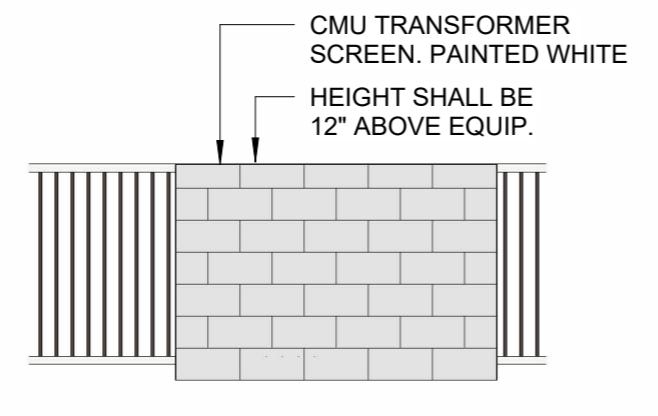

5 MECH. EQUIP. SCREEN WALL
1/4" = 1'-0"

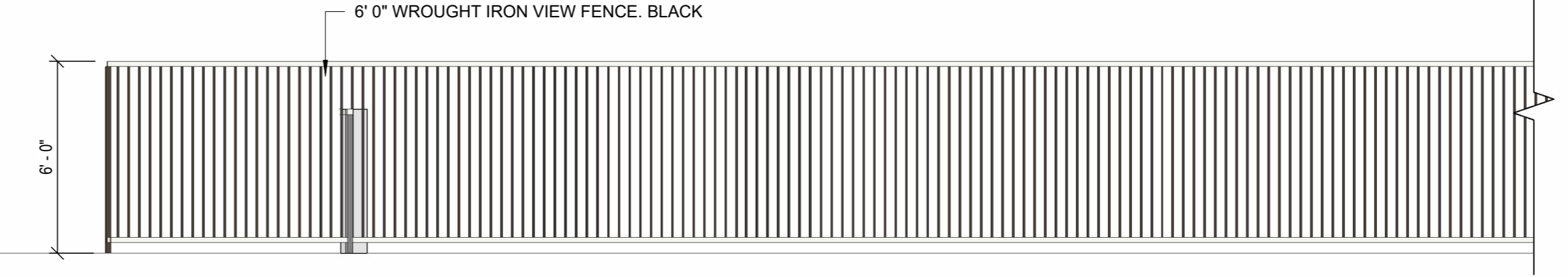

4 SITE WALL EAST
1/4" = 1'-0"

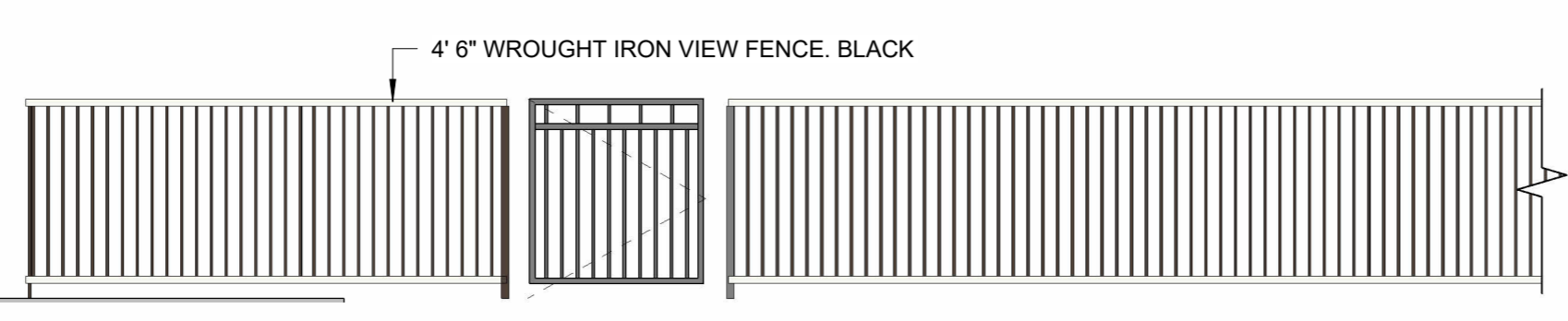

3 SITE WALL WEST
1/4" = 1'-0"

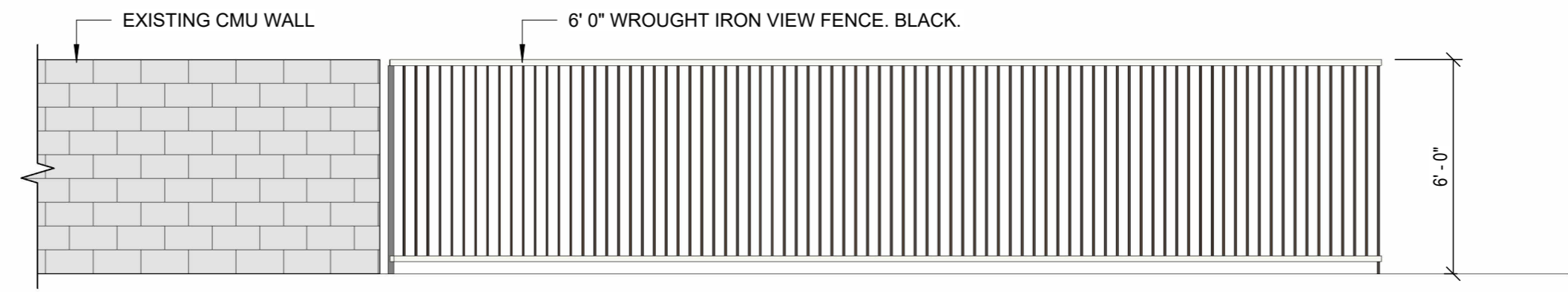

2 SITE WALL NORTH
1/4" = 1'-0"

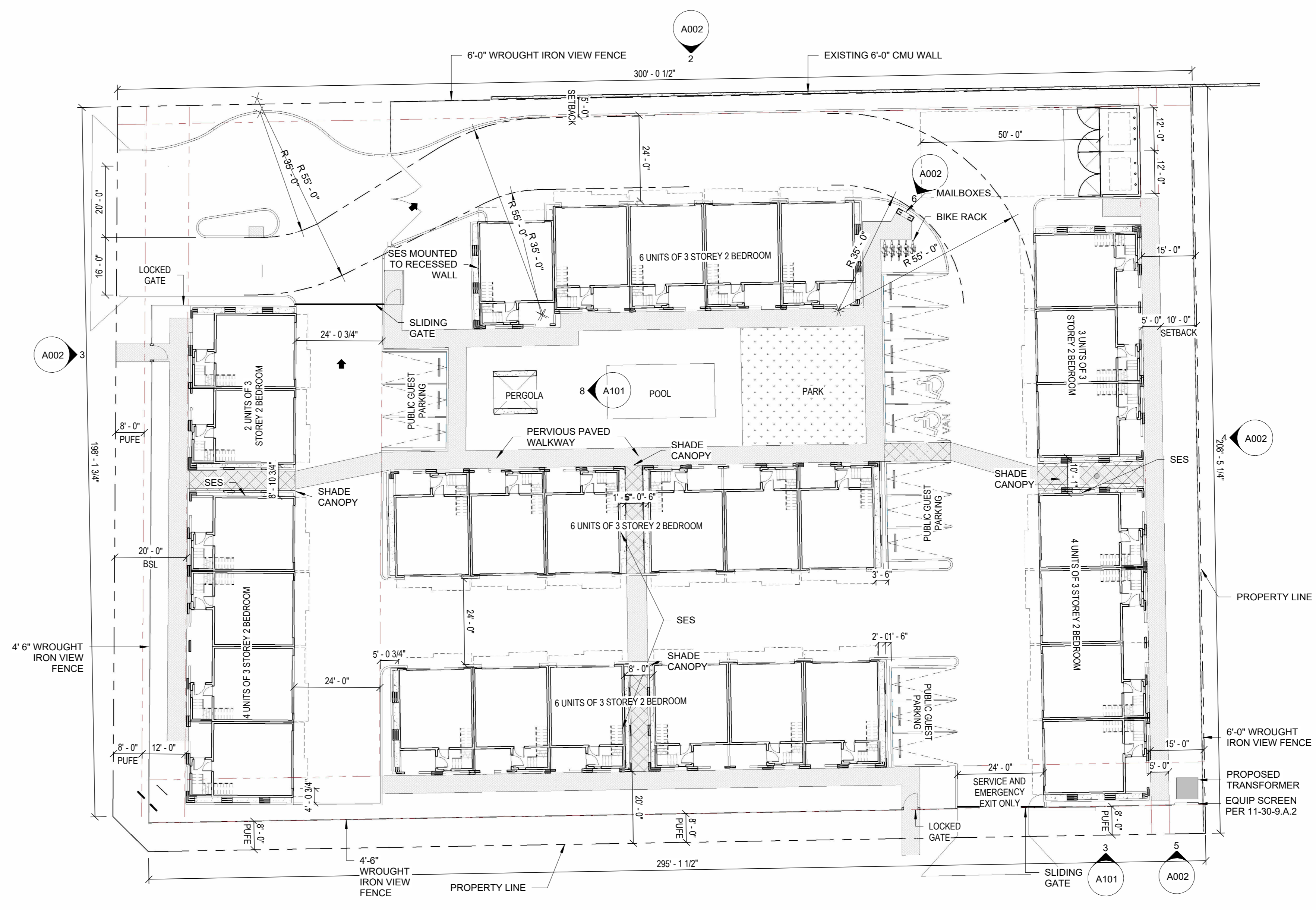

1 SITE WALL PLAN
1" = 20'-0"

**PRELIMINARY
NOT FOR
CONSTRUCTION**

no.	date	description

TANGERINE

421 N HALL
MESA, AZ 85208

PROJECT NO: 22039
DATE: 04/15/2024



atmosphere architects
p.o. box 5267
mesa, az 85211

contact: Tim Boyle
email: tim@atmosarch.com
tel: 917-526-0323

**SITE WALL PLAN
A002**

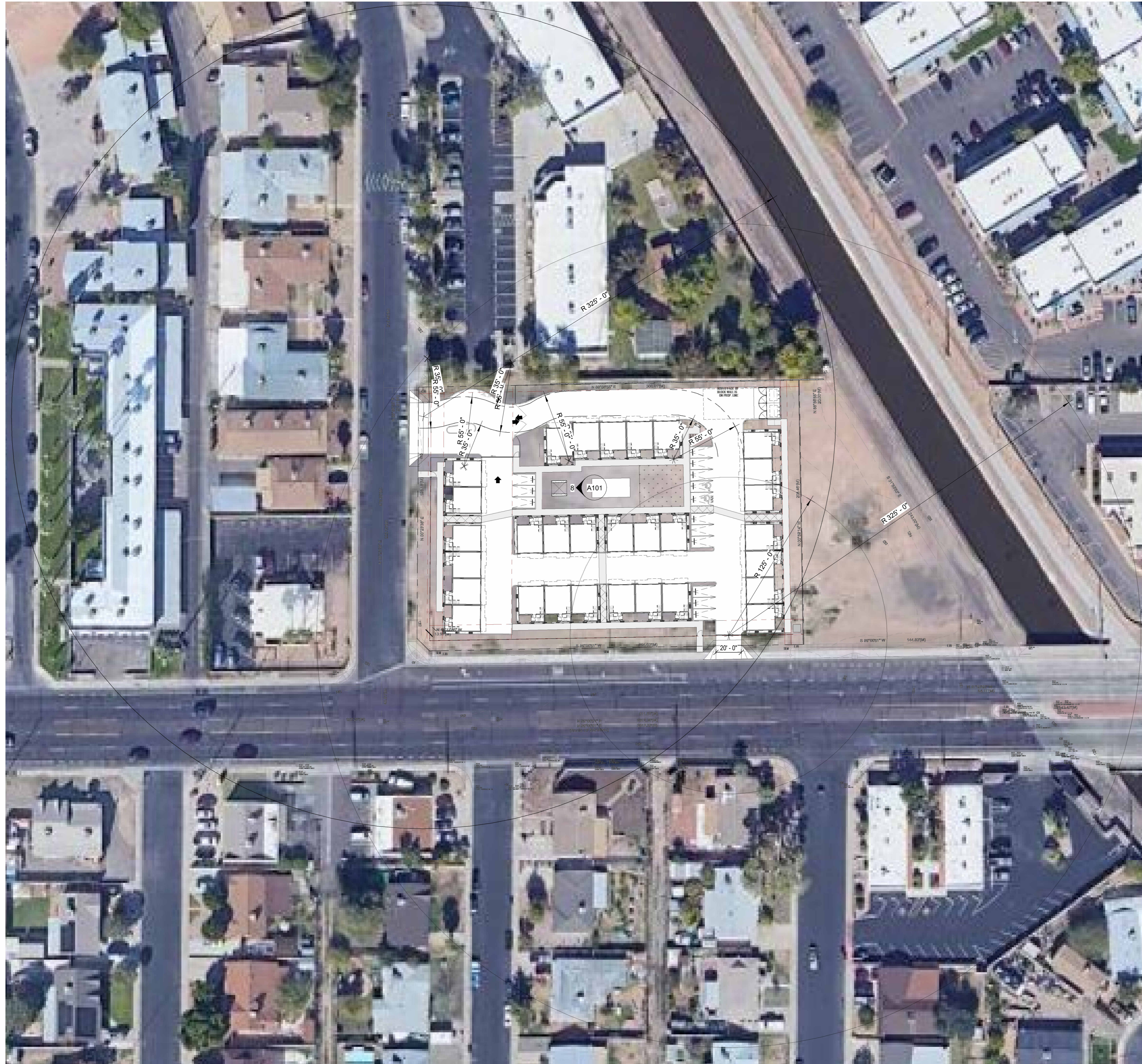

① TRANSPORTATION PLAN
1" = 40'-0"

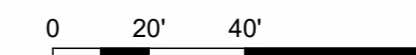

**PRELIMINARY
NOT FOR
CONSTRUCTION**

no.	date	description

TANGERINE

421 N HALL
MESA, AZ 85208

PROJECT NO: 22039
DATE: 04/15/2024



atmosphere architects
p.o. box 5267
mesa, az 85211

contact: Tim Boyle
email: tim@atmosarch.com
tel: 917-526-0323

**TRANSPORTATION
PLAN
A003**

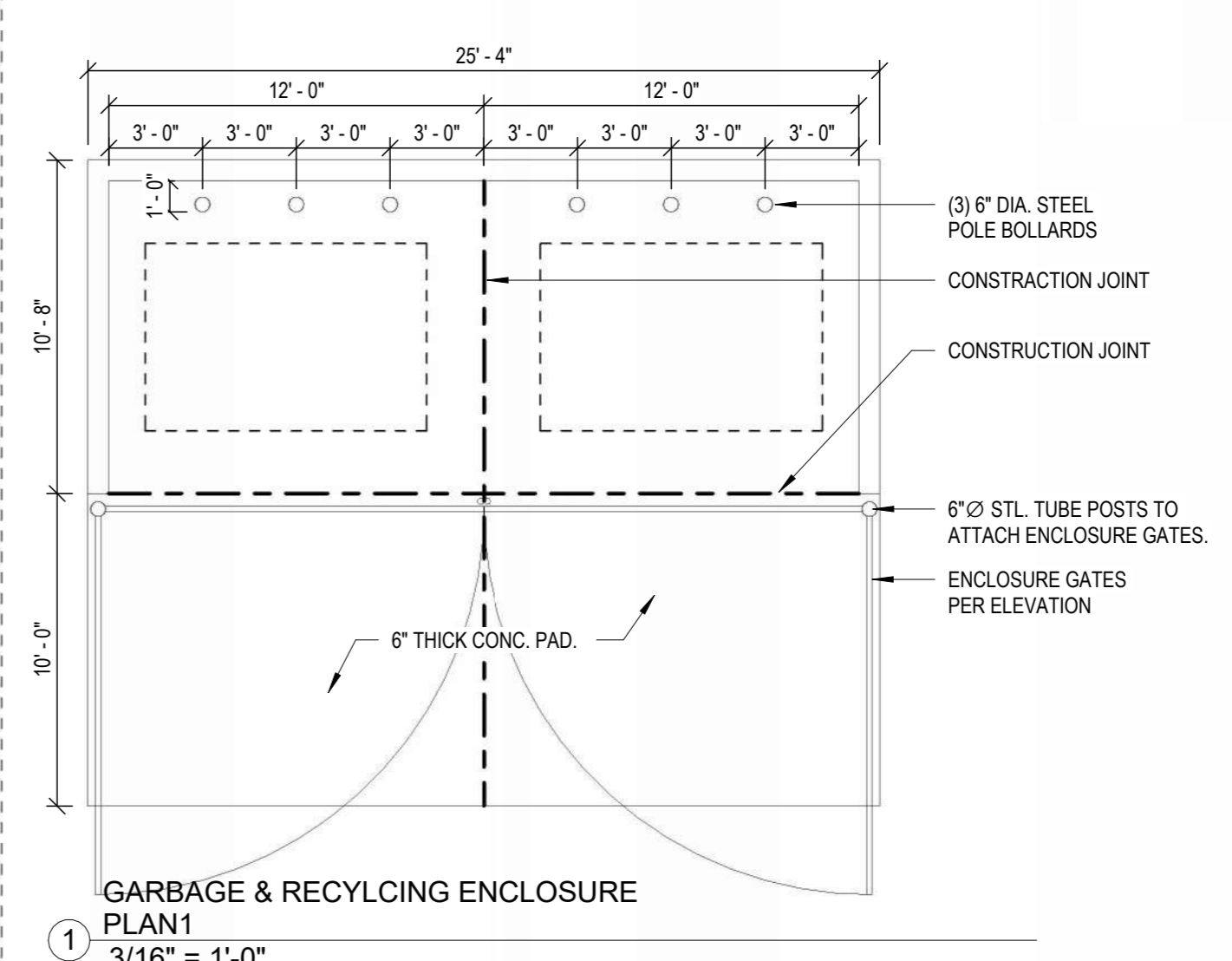
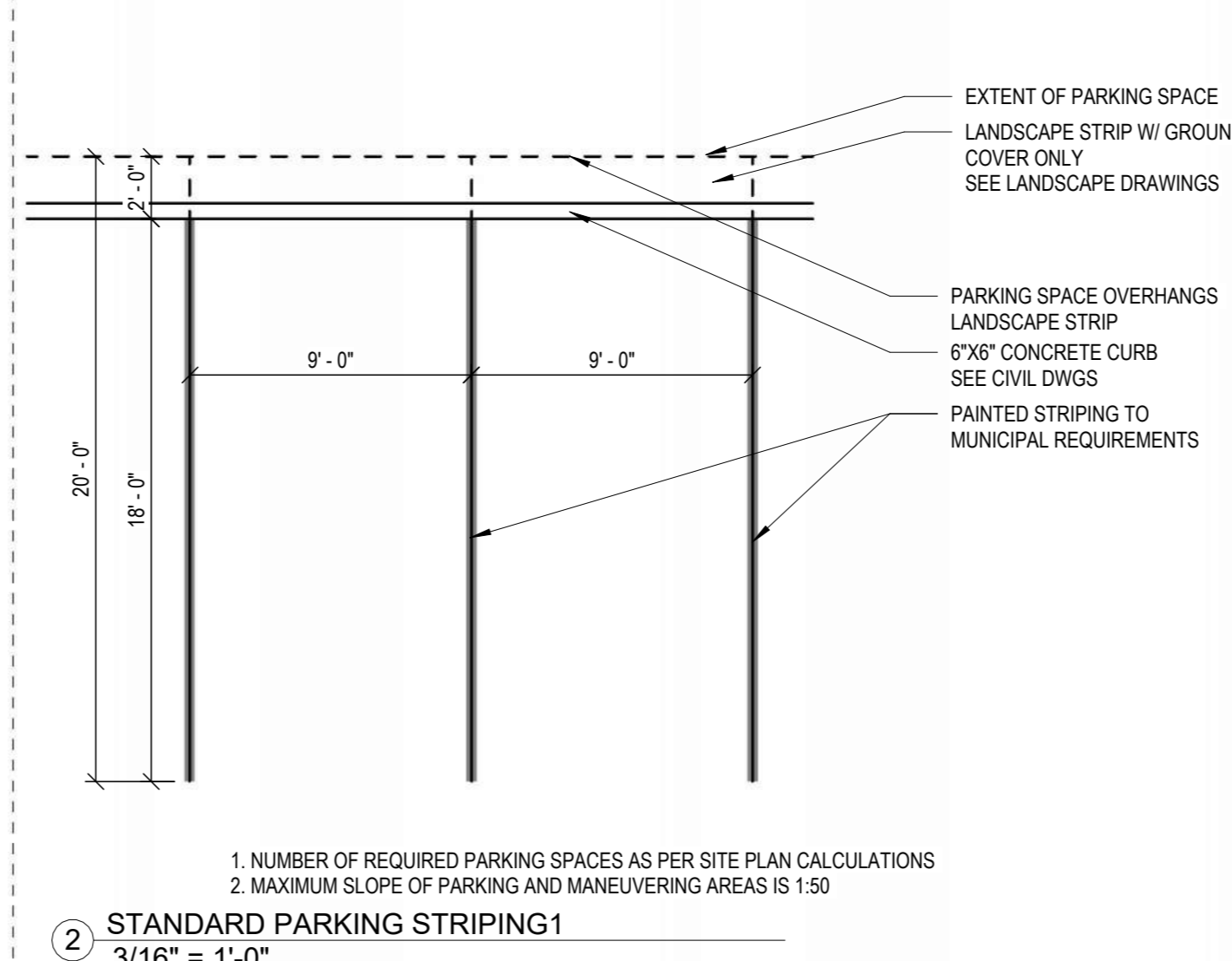
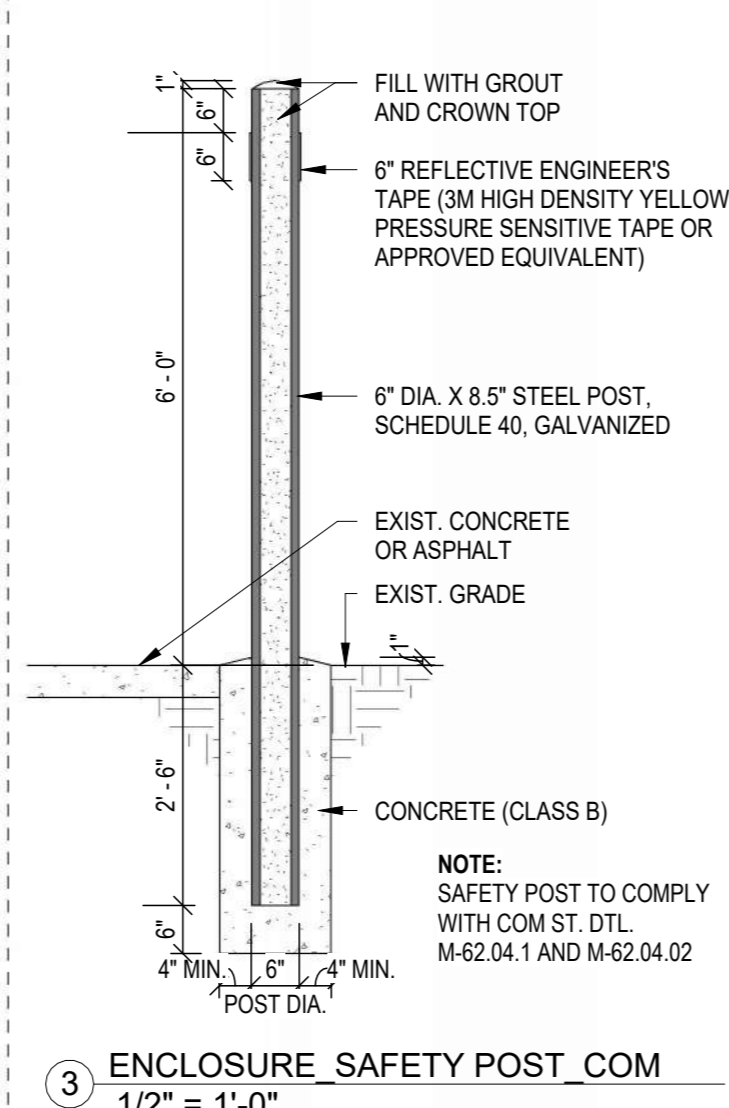
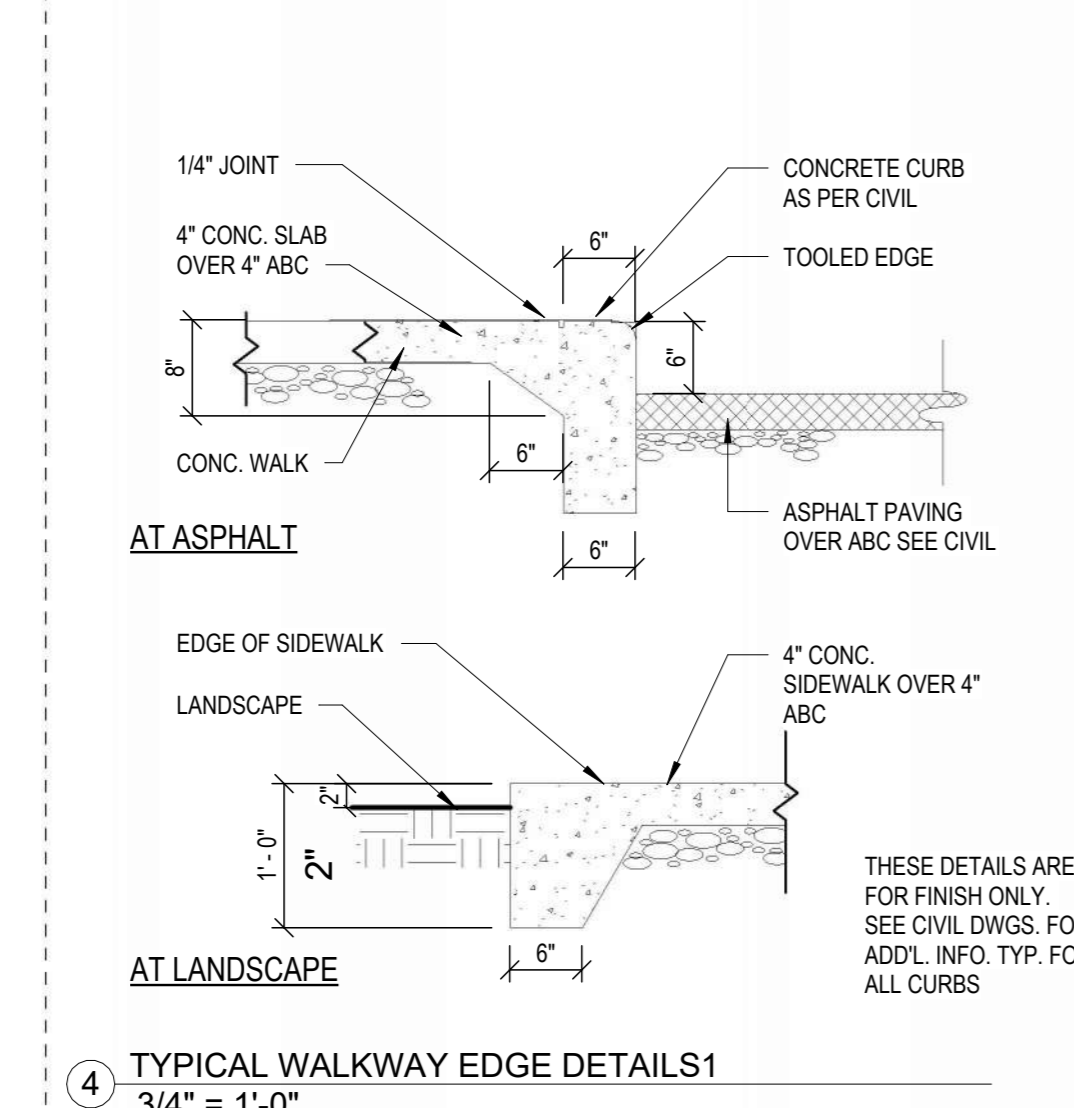
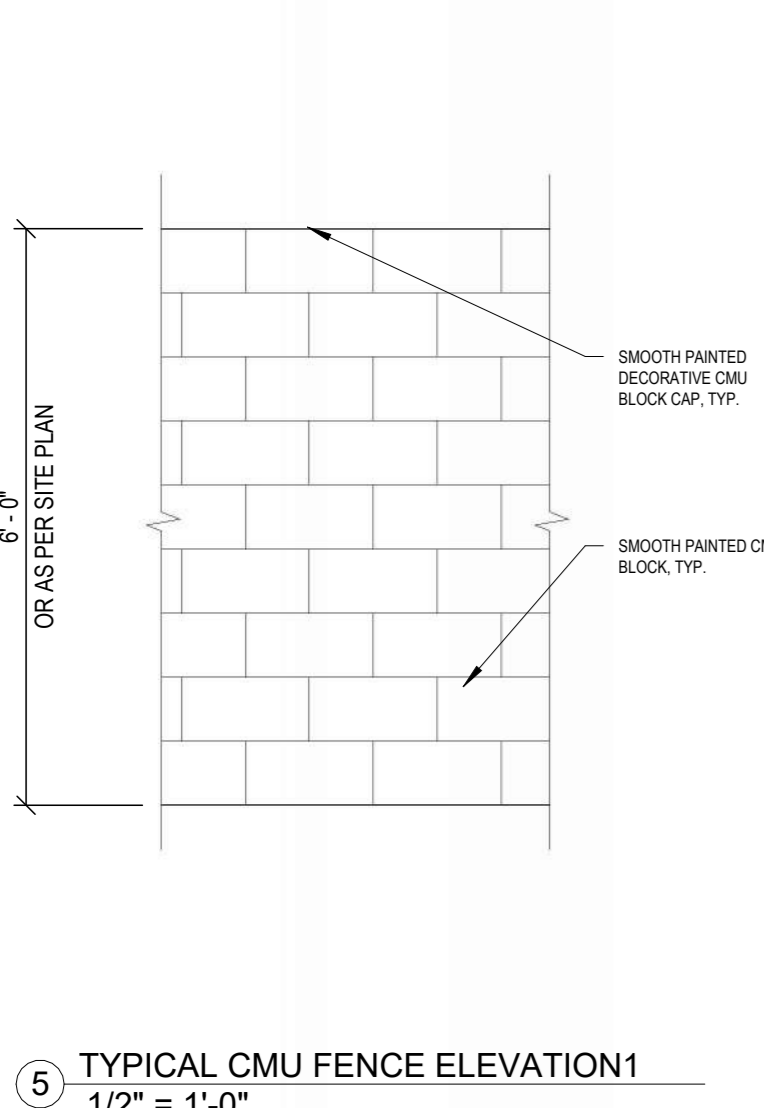
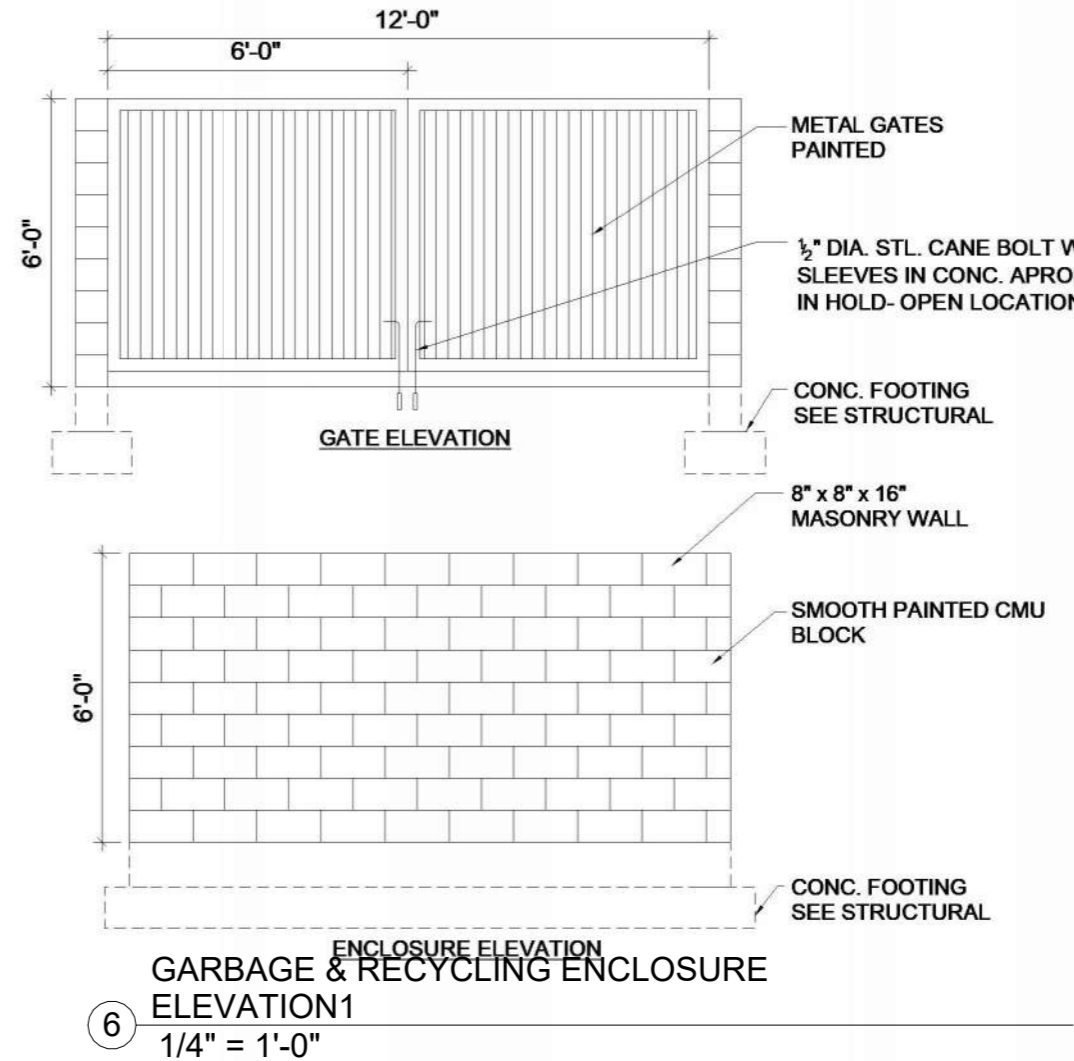
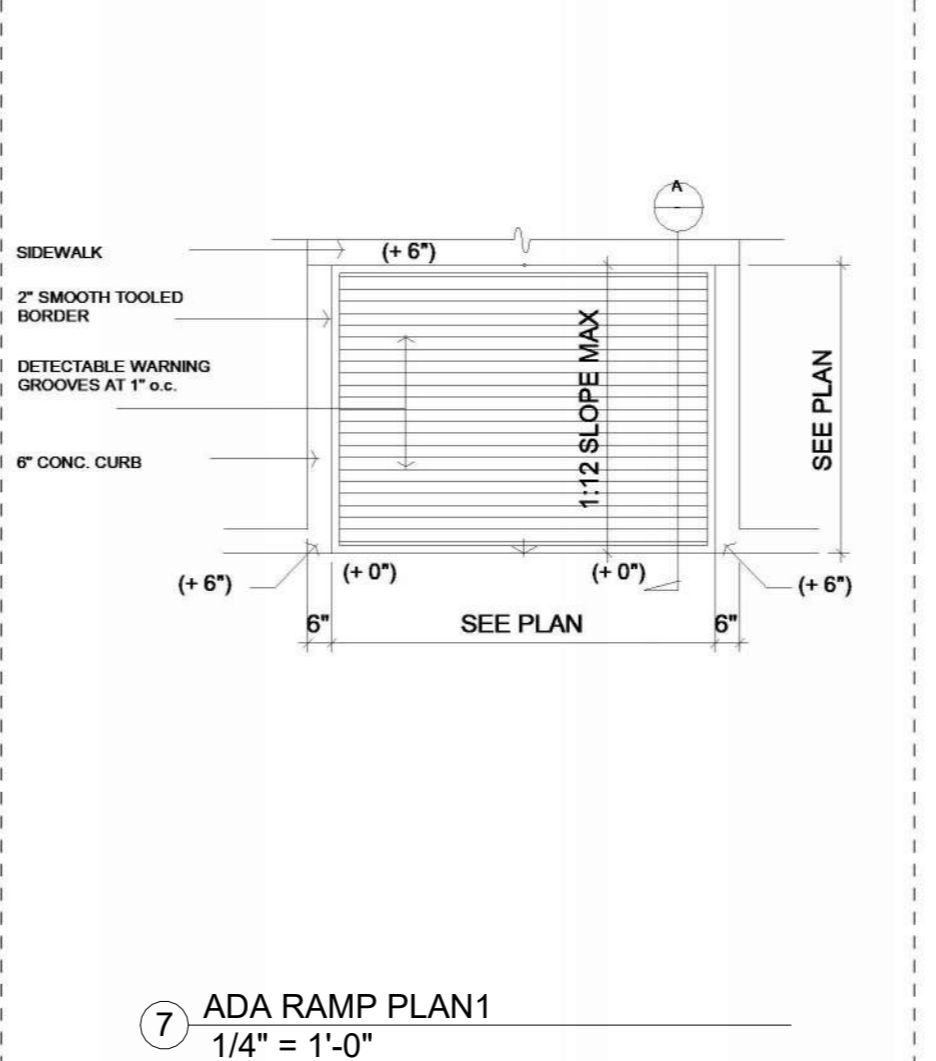
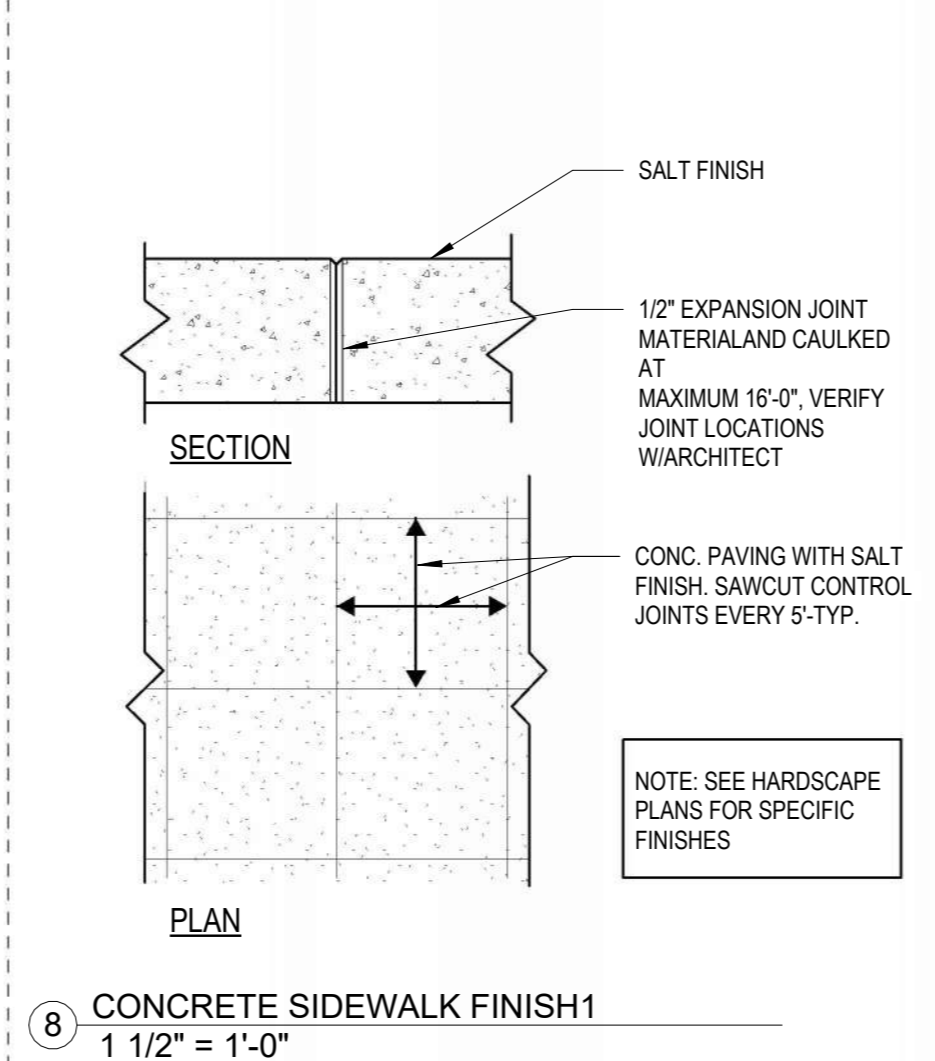
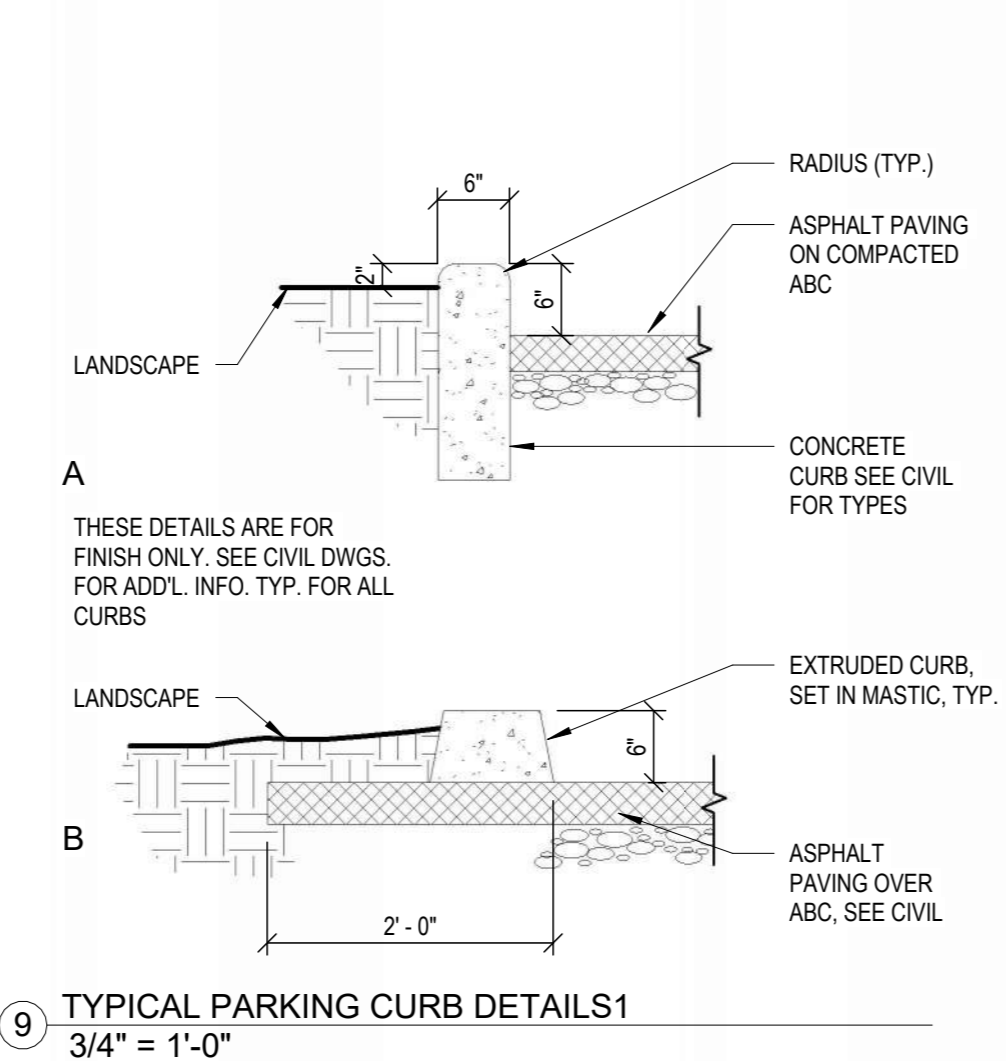
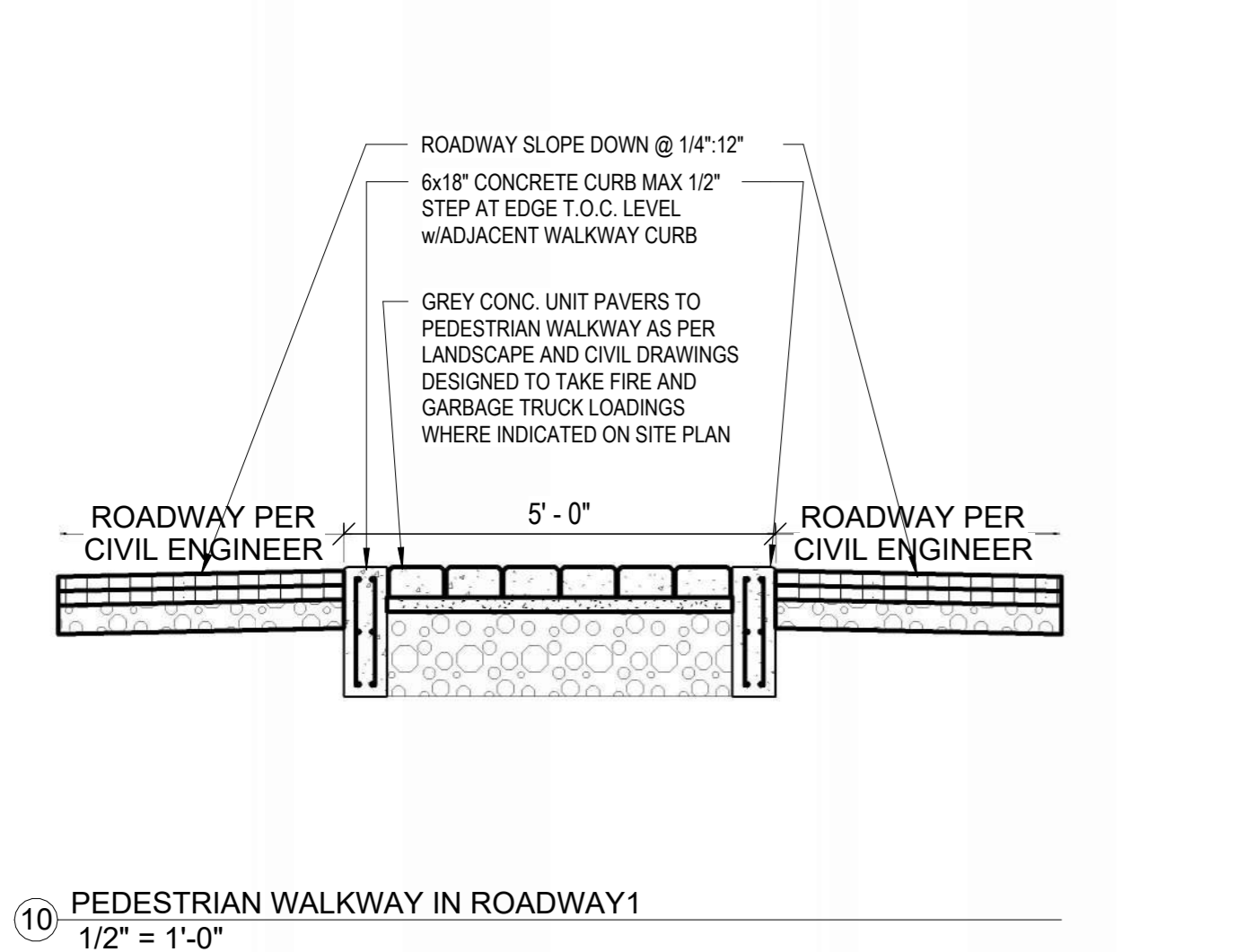
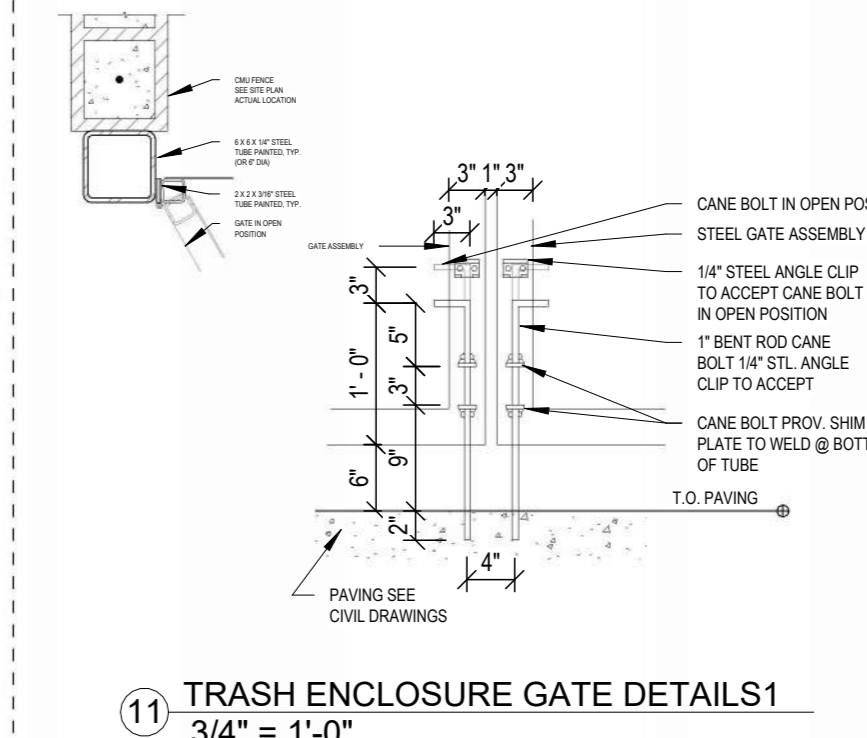
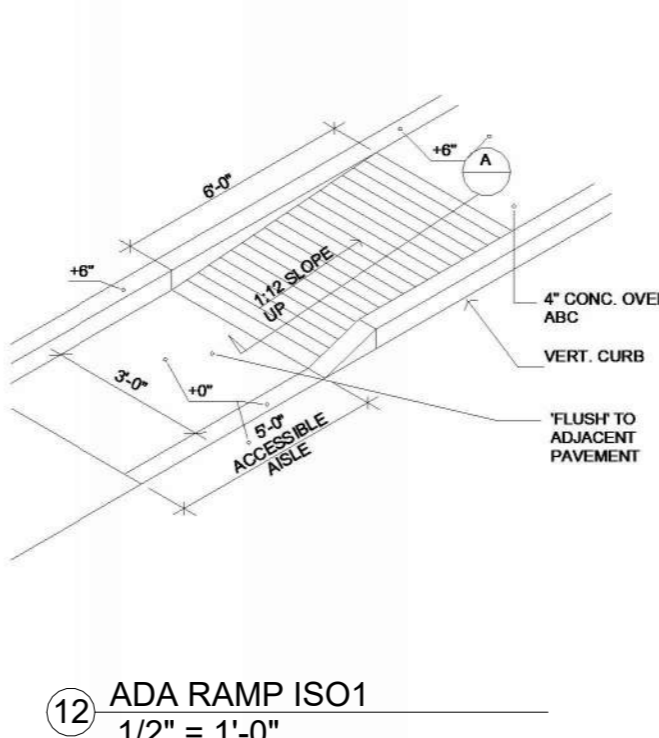
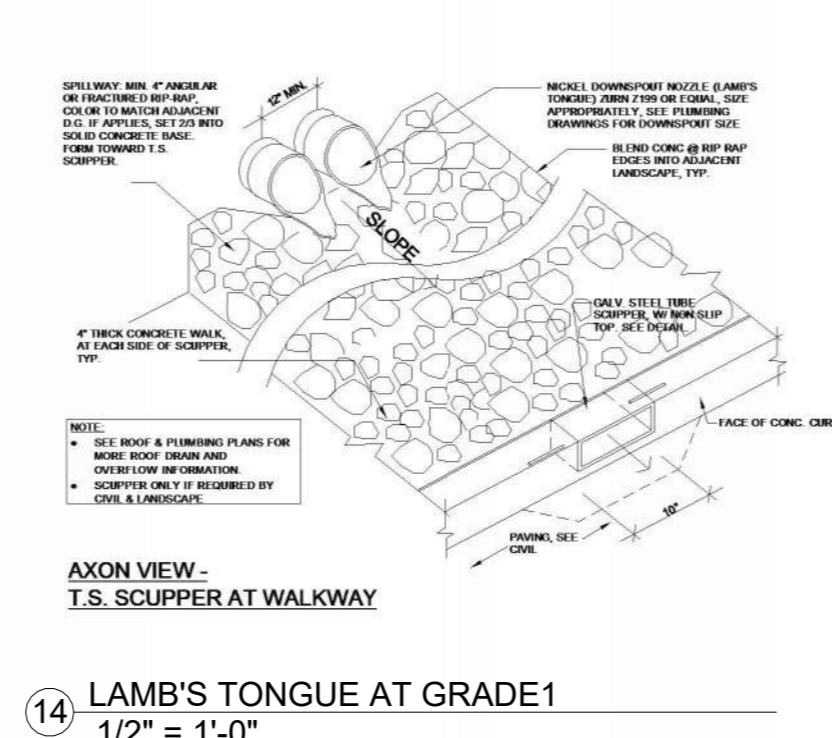
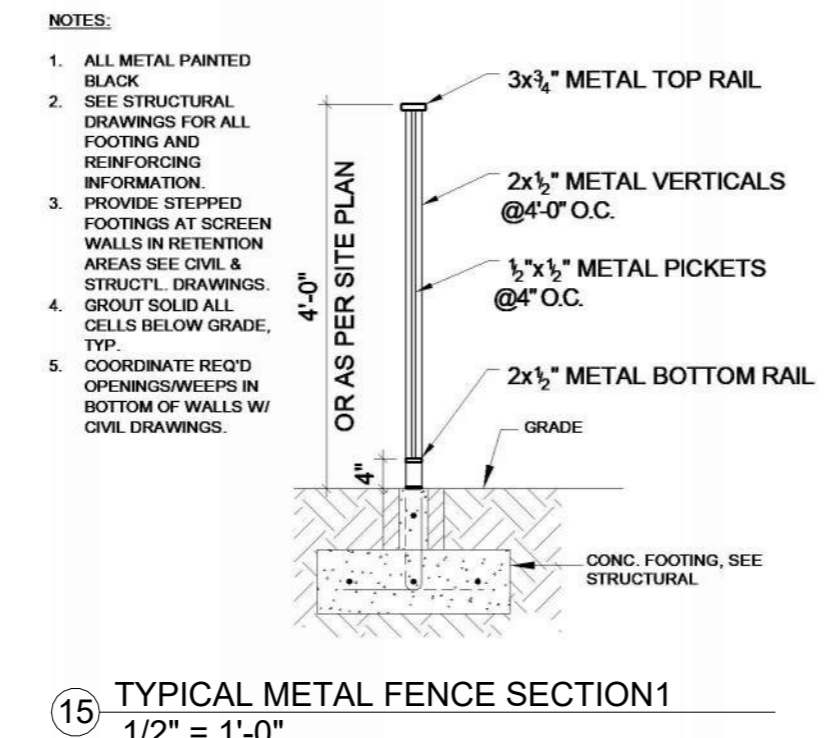
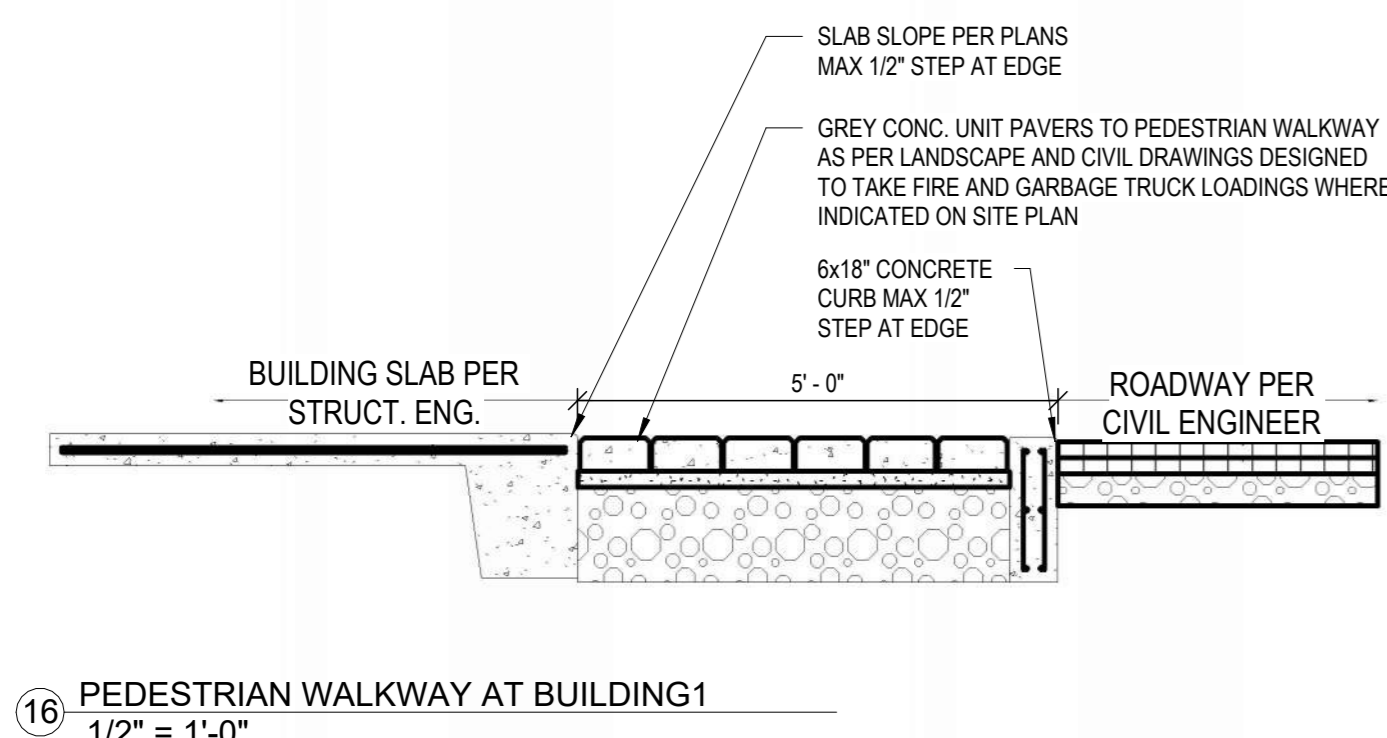
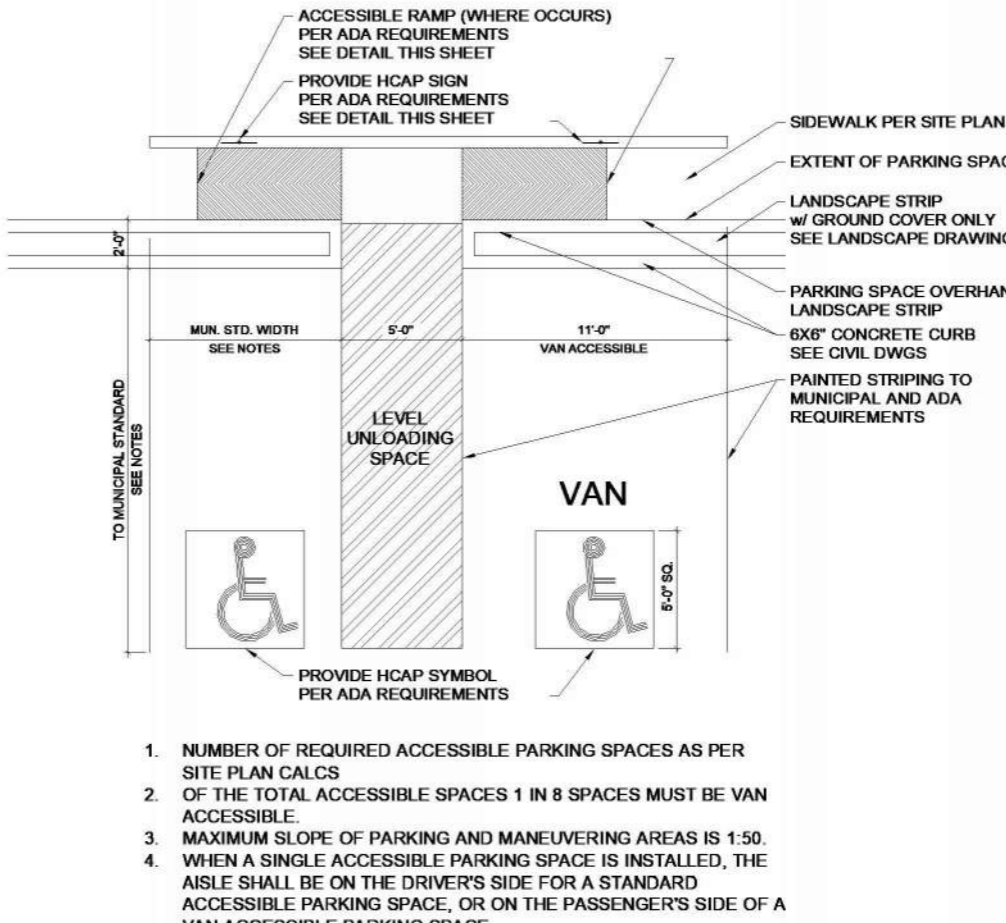
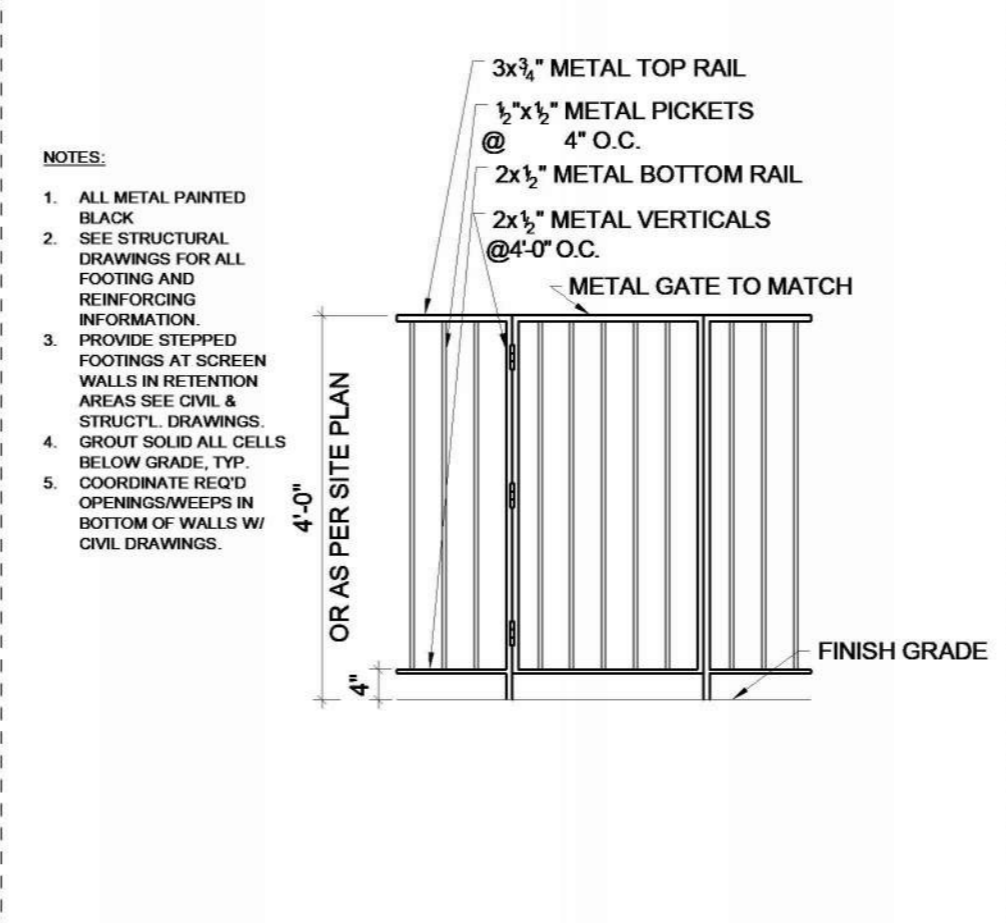
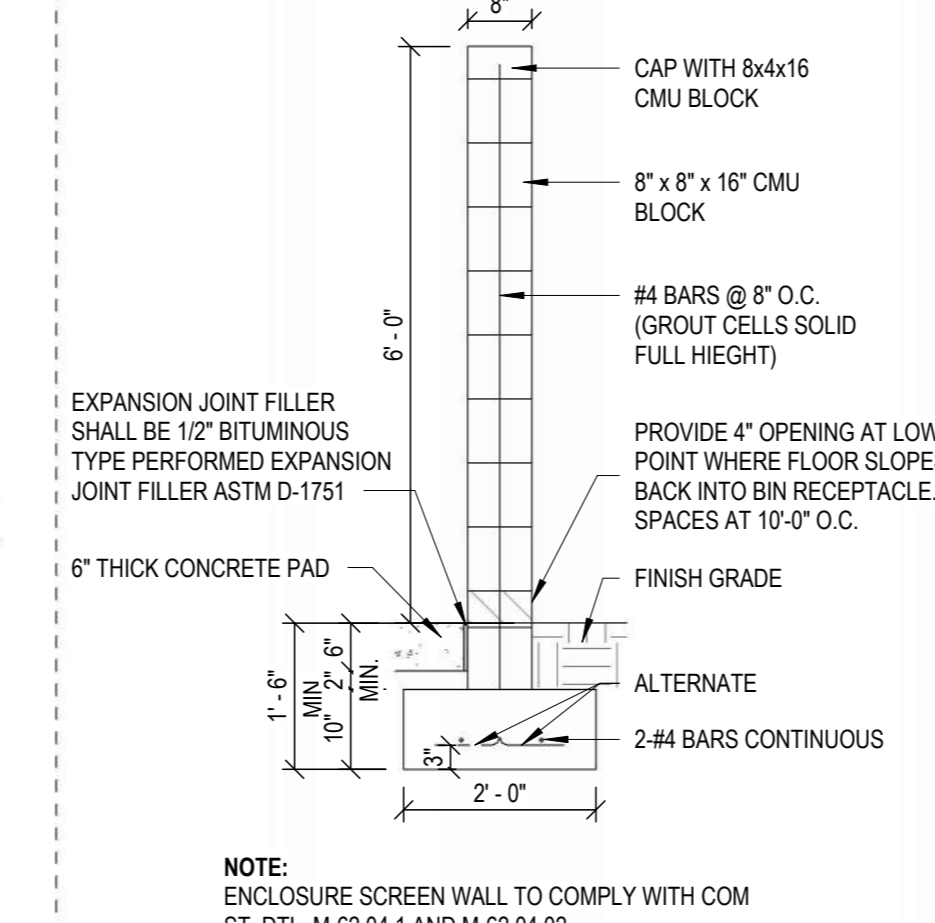
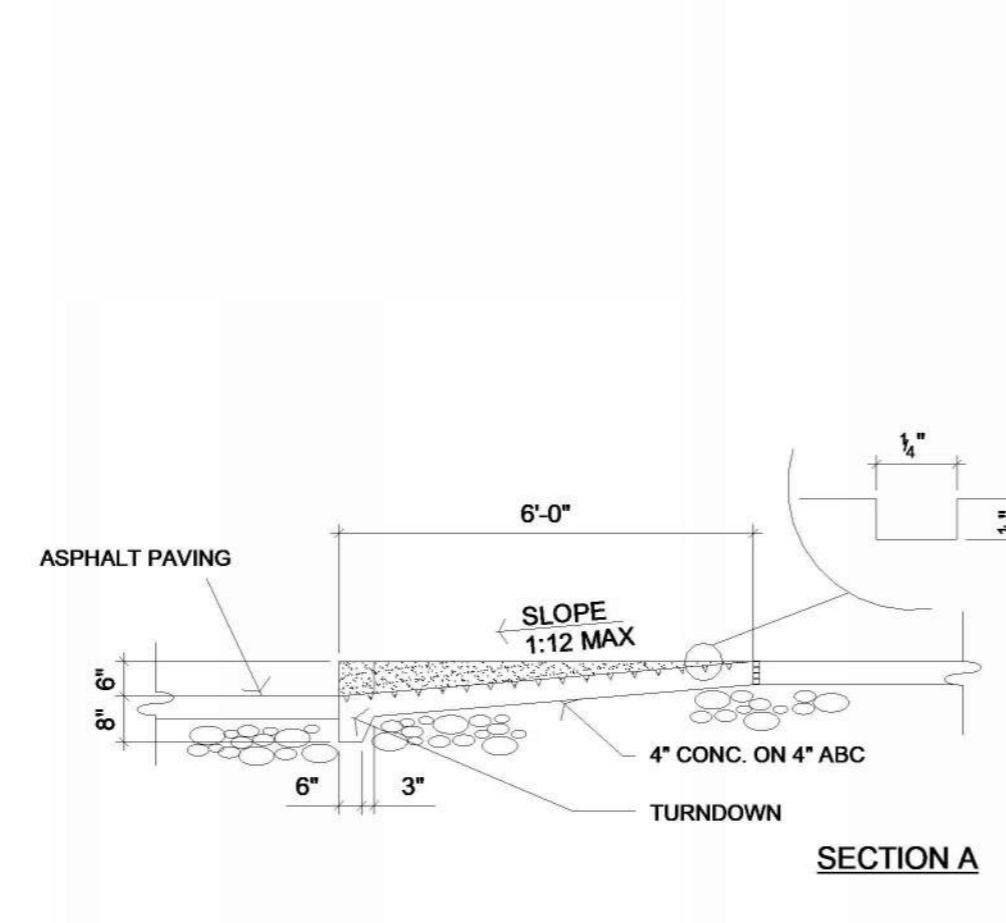
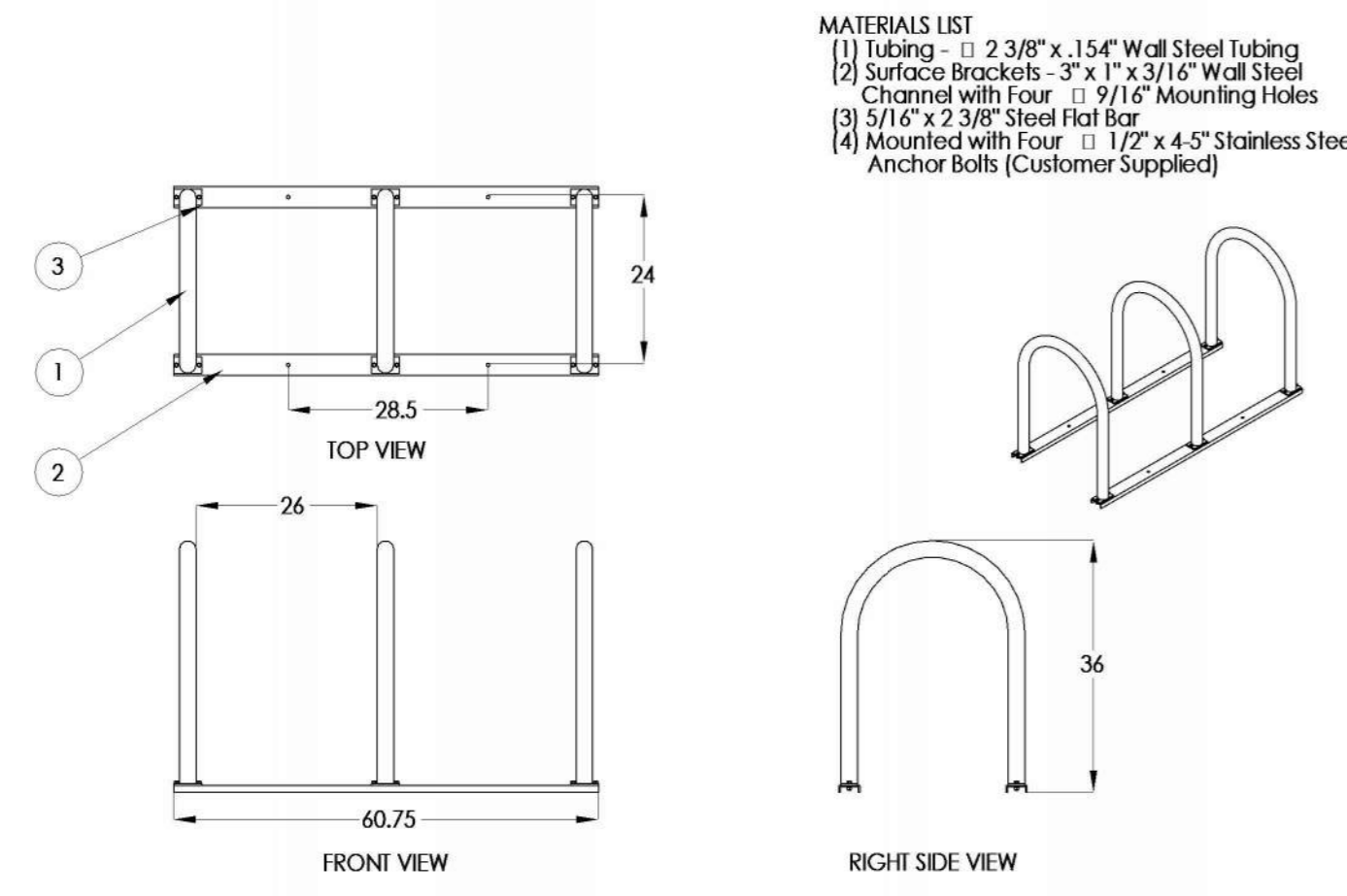

**PRELIMINARY
NOT FOR
CONSTRUCTION**

no.	date	description

TANGERINE

421 N HALL
MESA, AZ 85208

PROJECT NO: 22039
DATE: 01/24/23

atmosphere
architects

atmosphere architects
p.o. box 5267
mesa, az 85211

contact: Tim Boyle
email: tim@atmosarch.com
tel: 917-526-0323

**TYPICAL SITE
DETAILS
A004**

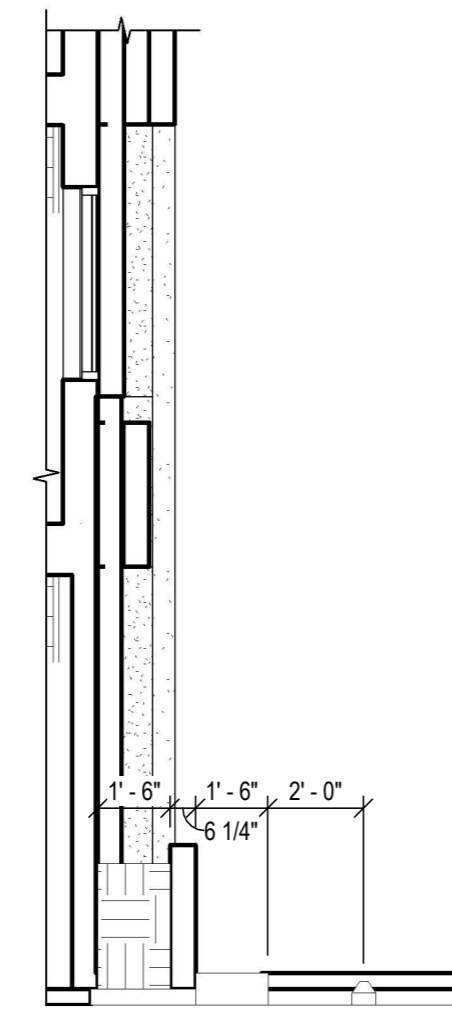

7 PLANTER FOUNDATION
1/4" = 1'-0"

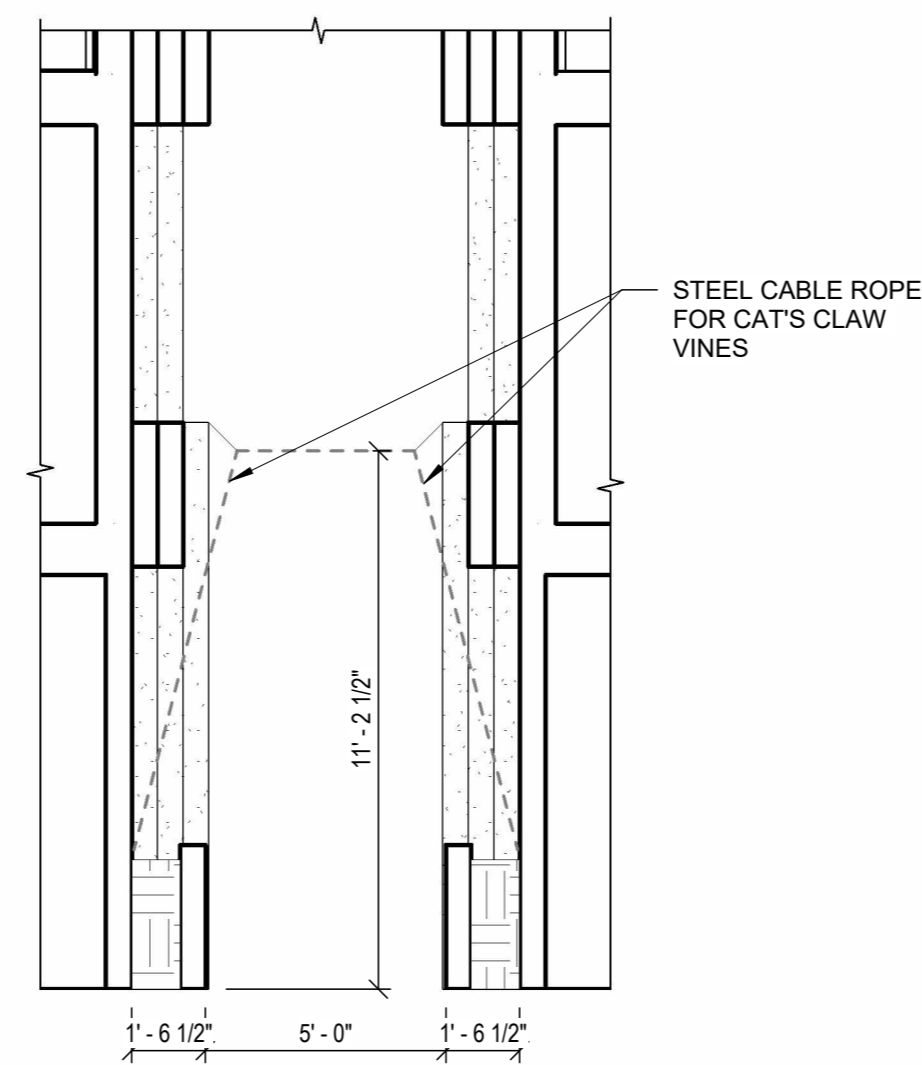

6 SECTION - WALKWAY SHADE
1/4" = 1'-0"

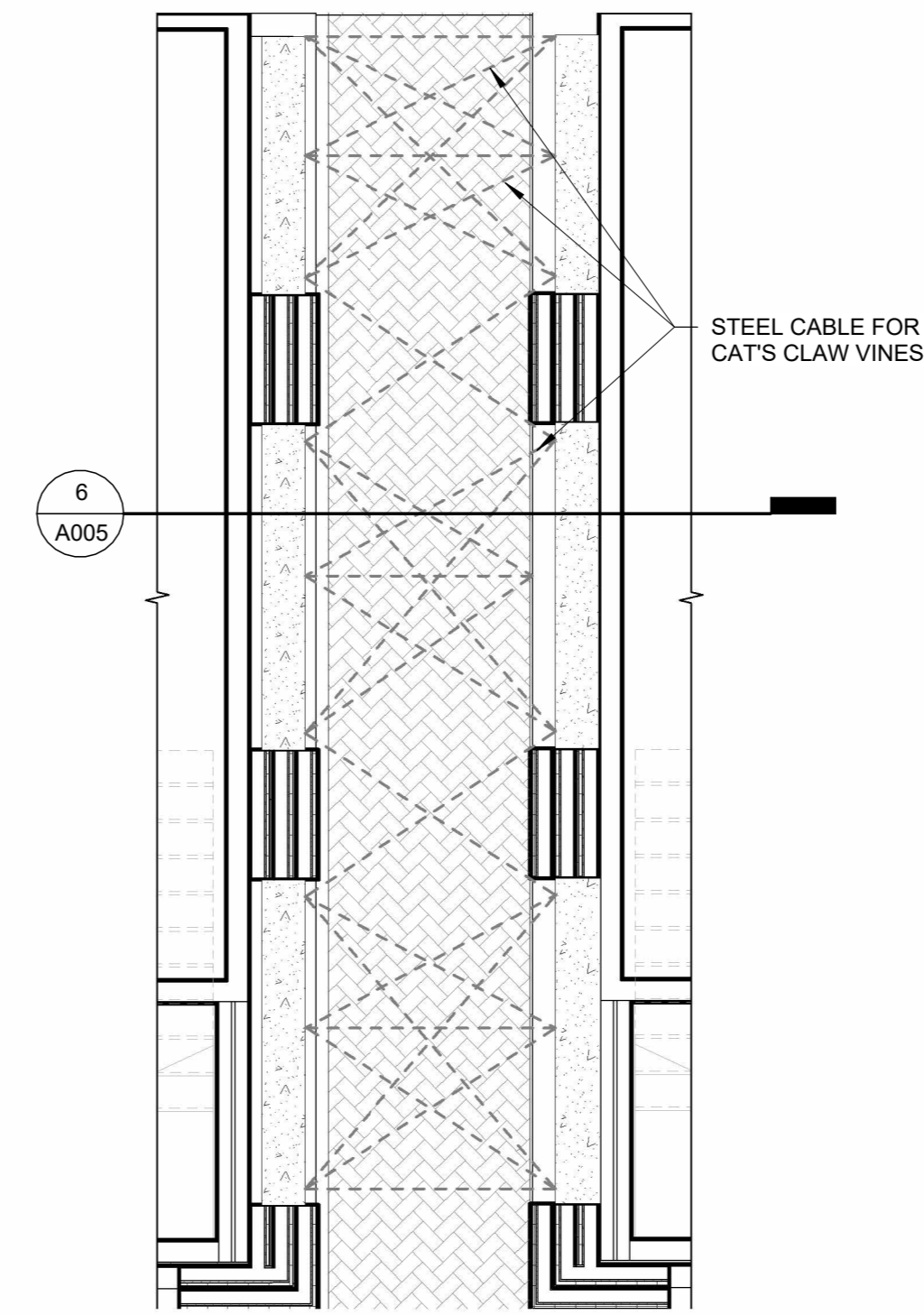

5 PLAN - WALKWAY SHADE
1/4" = 1'-0"

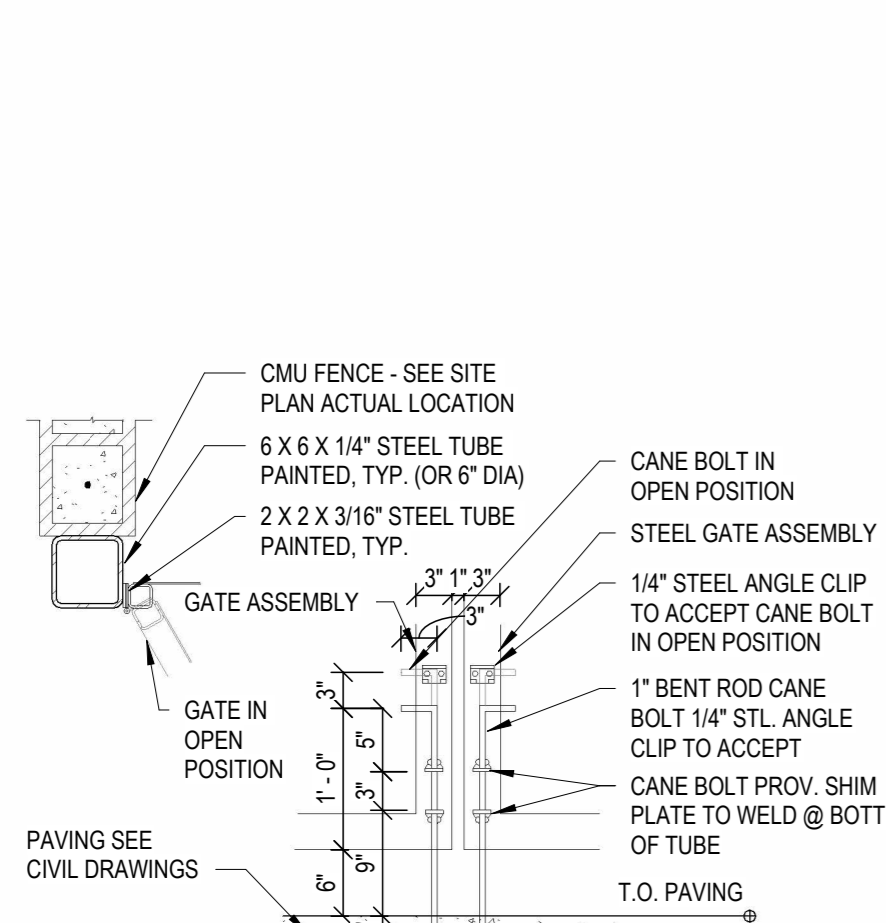

4 SITE - TRASH ENCLOSURE GATE
DETAIL
3/4" = 1'-0"

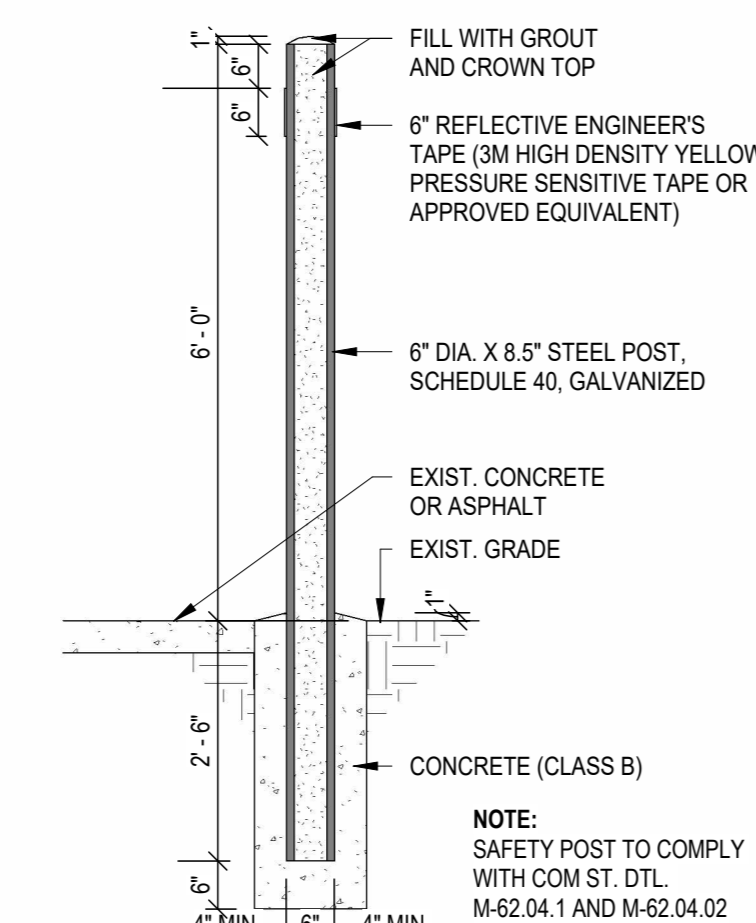

3 ENCLOSURE SAFETY POST_COM
1/2" = 1'-0"

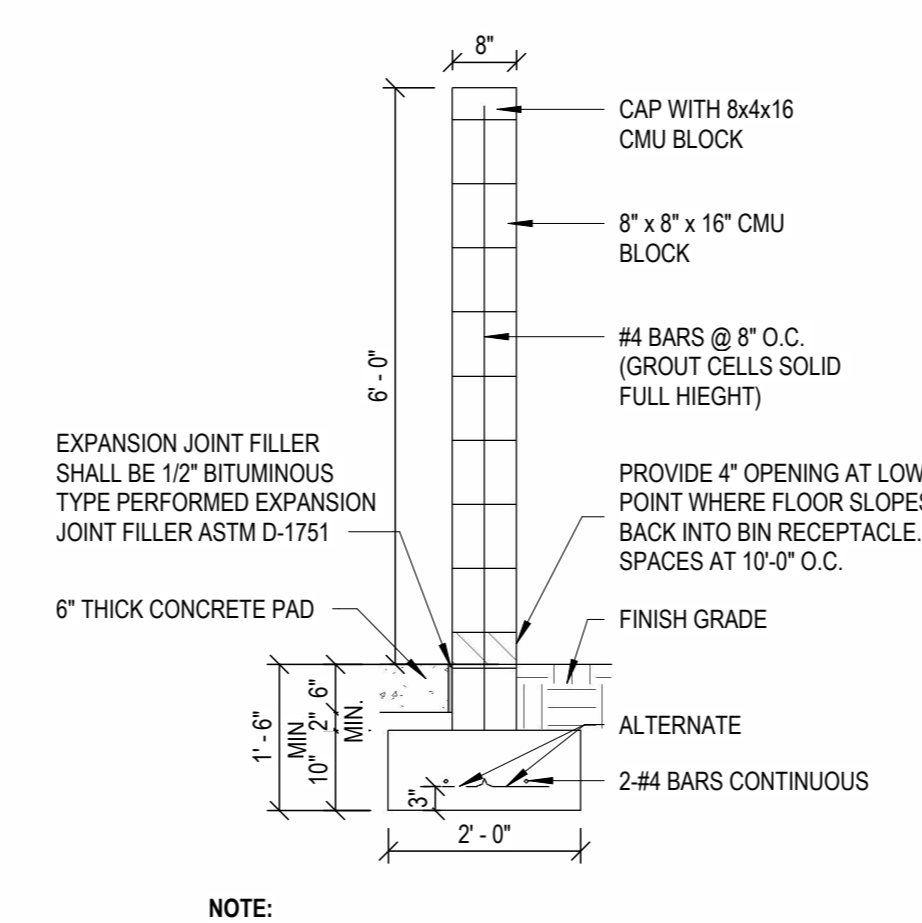

2 ENCLOSURE SCREEN WALL_COM
1/2" = 1'-0"

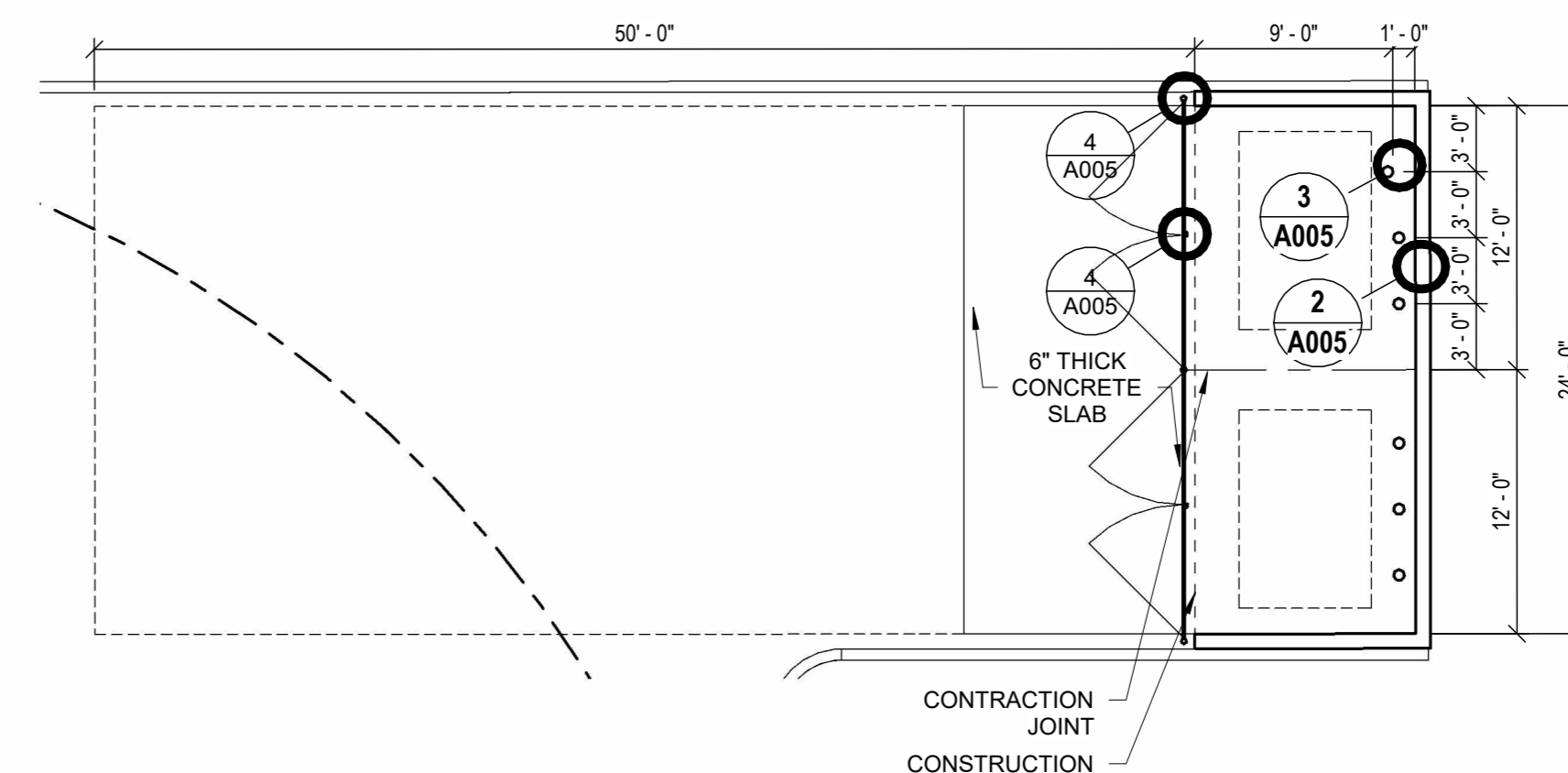

1 ENLARGED SOLID WASTE
1/8" = 1'-0"

**PRELIMINARY
NOT FOR
CONSTRUCTION**

no.	date	description

TANGERINE

421 N HALL
MESA, AZ 85208

PROJECT NO: 22039
DATE: 04/15/2024



atmosphere architects
p.o. box 5267
mesa, az 85211

contact: Tim Boyle
email: tim@atmosarch.com
tel: 917-526-0323

**TYPICAL SITE
DETAILS**

A005